

Conquest[®]

Condensing Gas Water Heater



AquaPLEX[®]
Engineered Duplex Alloy

1100 to 1200 MBH | 15-year Warranty

PVI.com



Advanced Design with Longer Service Life

Conquest is a compact, high-efficiency, condensing, firetube water heater that combines an advanced fuel-saving design with extended product life. It features a submerged combustion chamber and a heat exchanger with a dimpled array of firetubes fabricated entirely from durable, corrosion-resistant AquaPLEX® duplex stainless steel alloy. Built from the best material, Conquest provides superior payback with 3-5 times the warranty of competitors.

The 1100 and 1200 MBH Conquest provides more BTUs in a smaller space and is able to be installed through a 36-inch doorway with minimal floor space requirements.

Features and Benefits

- 1100 and 1200 MBH
- For 1100 MBH model CQT1100
 - 96% thermal efficiency from 40°F to 140°F
 - 96% thermal efficiency from 70°F to 140°F
- For 1200 MBH model CQT1200
 - 97% thermal efficiency from 40°F to 140°F
 - 97% thermal efficiency from 70°F to 140°F
- Seamless modulation reduces cycling and improves efficiency up to 99% during low load
- Less than 20 ppm NOx
- Touch-screen operating control with plain text status and fault diagnostics, BACnet embedded
- 15-year tank and heat exchanger corrosion warranty (8 years full, 7 years pro-rated)

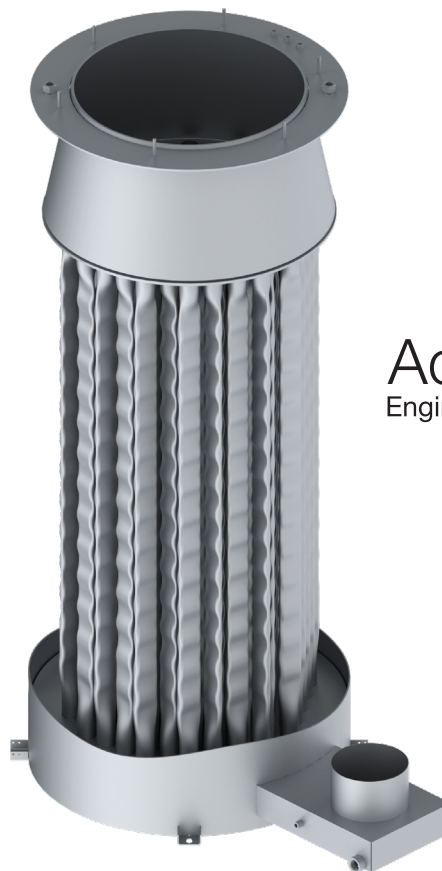

AquaPLEX®
Engineered Duplex Alloy

Durable and Efficient

Corrosion Resistant

The AquaPLEX tank is inherently immune to aqueous corrosion and entirely eliminates the need for a tank lining or anode rods, whether sacrificial or impressed current. Unlike 316L stainless steel, AquaPLEX is immune to chloride stress corrosion cracking, a known failure mode of 316L in hot potable water. AquaPLEX combines the grain structures of both 300 and 400 series stainless steels for unequalled corrosion protection.

Condensing Efficiency

Conquest delivers high efficiency through a completely submerged, single-pass, down-fired design, which includes an array of dimpled fire tubes. Combustion gases are counter-flow to the direction of the potable water enabling the coolest flue gases to contact the coldest water and raising low-fire efficiency to 99%.



High Efficiency in the Lab and on the Job

Integral Tank Circulator

During burner operation, Conquest energizes a volute-less circulating pump that forces water across the heating surfaces in the hottest part of the tank. More aggressive contact between the water and heating surfaces improves efficiency and the scouring action helps to reduce the buildup of scale. Circulation also helps to equalize tank temperature.

Dedicated Hot Water Return Connection

Circulation of hot water into the cold fitting on a condensing water heater lowers the efficiency. Conquest provides a dedicated fitting for connection to building return loops or side-arm tanks, maintaining two distinct temperature zones and allowing only the coldest water to enter the lower condensing zone of the water heater during a firing cycle to increase efficiency.

Low Standby Losses

Conquest's fiberglass insulation and a small tank size reduce standby losses far below ASHRAE 90.1 limits averaging about \$50 annually.

Modulation Increases Efficiency and Reduces Cycling During Low Demand

To reduce burner cycling during periods of low hot water demand, the Conquest water heaters employ burner modulation with a variable speed blower. This allows low flow conditions to be met with continuous, low BTU input and without short-cycling. The reduction in energy input also improves thermal efficiency up to 99%. During periods when nominal demand is only a few gpm, the at-temperature storage capacity of the Conquest heater can meet the hot water requirement for 20 to 40 minutes before a burner cycle is required.



Venting Flexibility

Multiple Positive-Pressure Venting Options

Conquest is a category IV vented product listed for PVC, CPVC and Polypropylene materials. Capable of sealed combustion with terminations in different pressure zones. Concentric venting is available.

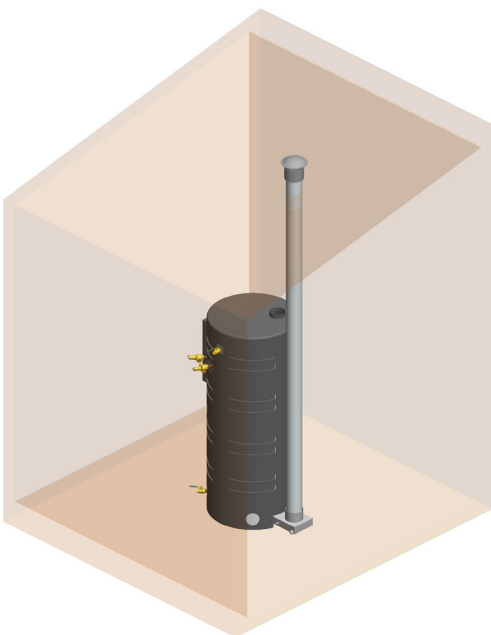

Conventional

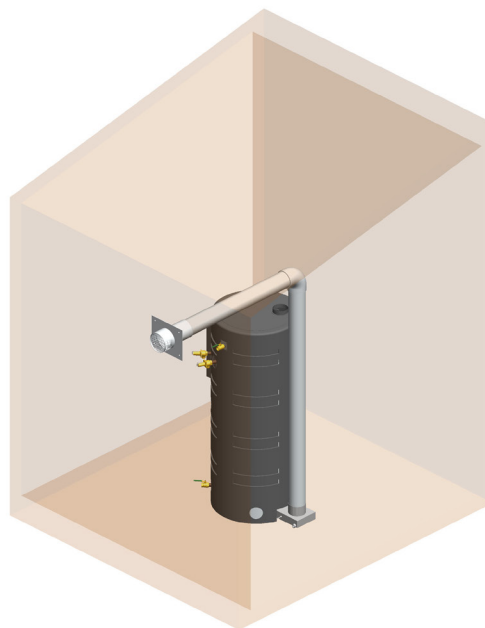

Room air, side-wall vent

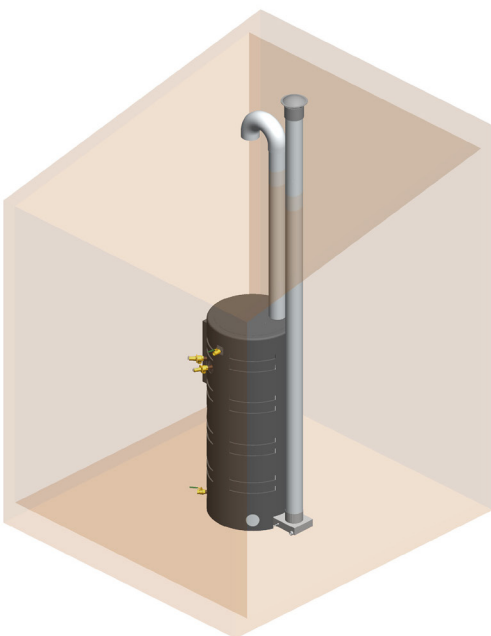

Sealed combustion with
roof terminations

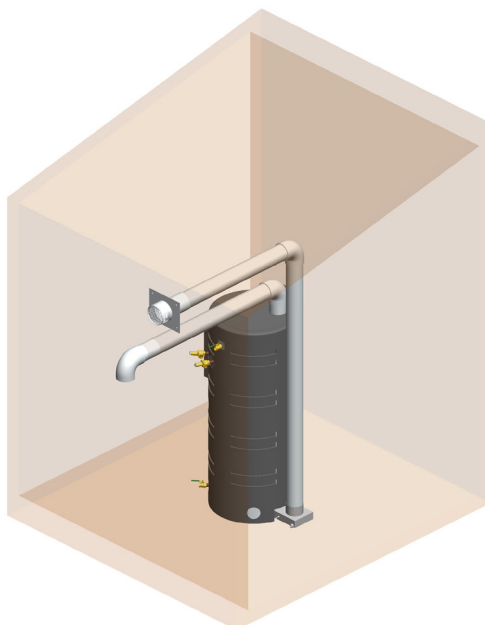

Sealed combustion with
sidewall terminations

Features and Codes

Touch-Screen Operating Control

Conquest's electronic operating control provides a plain-text user interface that indicates heater status, modulation rate, operating parameters and fault status. The control is embedded with Modbus RTU and BACnet MS/TP protocols for connection to a building automation system. The control includes a 15-event fault history that tracks operating safeties and hardware/software points for speed and accuracy in troubleshooting.

Selected Standard Equipment

- Up to 96% thermal efficiency at full fire from 40-140°F for 1100 MBH model CQT1100
- Up to 97% thermal efficiency at full fire from 40-140°F for 1200 MBH model CQT1200
- Up to 99% thermal efficiency at low fire
- < 20 ppm NOx, SCAQMD listed
- Equipped for direct combustion air connection
- Vents through PVC, CPVC, Polypropylene or stainless steel
- 15-year warranty for tank and exchanger (8 years full, 7 years pro-rated)

Pressure Vessel and Heat Exchanger

- AquaPLEX tank (duplex stainless steel)
- AquaPLEX 100% submerged combustion chamber and single-pass fire tubes
- Fire tubes have graduated dimpling to maintain high flue gas velocity
- Temperature and pressure relief valve
- Fiberglass insulation
- Polyethylene jacket
- Bottom drain valve

Burner, Operating and Safety Controls

- Pre-mix surface burner and proportional gas/air control
- Full burner modulation at 5-to-1 turndown
- ANSI, UL and FM compliant gas train
- Electronic operating system with integrated ignition and operating controls:
 - Programmable electronic operator with digital temperature readouts, adjustable from 70-180°F
 - Touch-screen interface with plain text status and fault indication with fault history
 - Alarm with remote contacts
 - Visual modulation rate
 - Manual-reset temperature limiting device
 - Modbus RTU and BACnet MS/TP embedded
- Electronic low-water cutoff with test switch
- Relay and proving contact for air louvers

Codes and Standards

- ASME HLW stamped for 150 psi
- Intertek /ELT listed to ANSI Z21.10.3/CSA 4.3
- Intertek /ELT listed for PVC, CPVC, or Polypropylene vent material and zero-clearance installation
- DOE/EPA qualified
- NSF/ANSI 372 low lead certified by ETL
- ASHRAE 90.1



ASHRAE 90.1 - 2013 compliant
SCAQMD compliant
NSF 372 lead-free

Specifications and Dimensions

Model ▼	Input BTU	Modulation	Recovery GPH (thermal efficiency)		Gas Connection NPT	Vent Diameter (ETL listed for longer vents w/ larger diameter)	Volume (gal.)	Operating Weight (lbs.)
			70-140°F ①	40-140°F ②				
CQT1100	1,100,000	Yes	1829 (96%)	1280 (96%)	1	6" @ 100 equivalent ft	100	1988
CQT1200	1,200,000	Yes	2016 (97%)	1411 (97%)	1	6" @ 100 equivalent ft	100	

① Recoveries and thermal efficiency derived from DOE 10 CFR 431 testing requirements (ANSI Z21.10.3 @ 70°F to 140°F).

② Recoveries and thermal efficiency based upon 40°F entering water temperature.

Dimensions are in inches unless otherwise indicated.

For standard and optional equipment, refer to form PV8849.

Empty weight is 1154 lbs. Shipping weight is 1354 lbs. for all models.

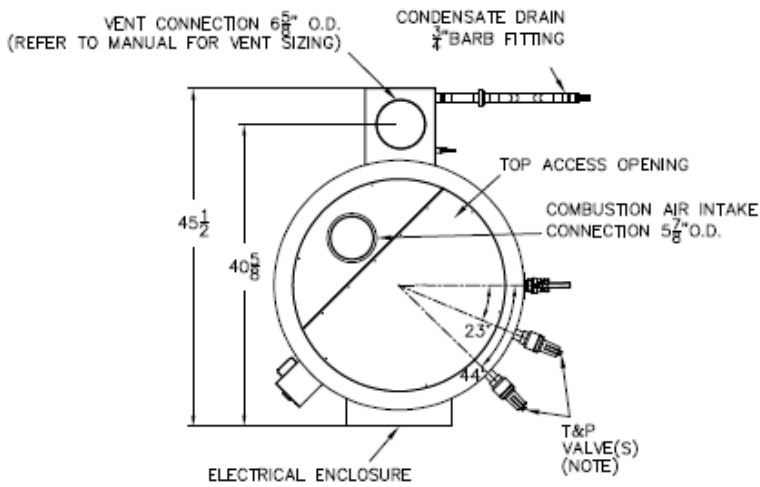

Standard Electric
120V, 1ø, 60 hz. (all models < 12 amps)
Gas Pressure (natural gas)
3.5" w.c. minimum flow pressure 14" w.c. maximum static pressure
Minimum Clearances
Zero inches from sides and rear 15 inches from top Can be installed on combustible floor
Emissions
< 20 ppm NOx, SCAQMD compliant

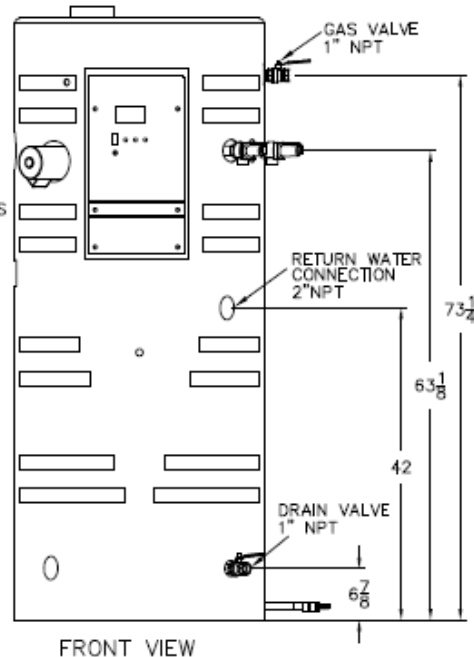
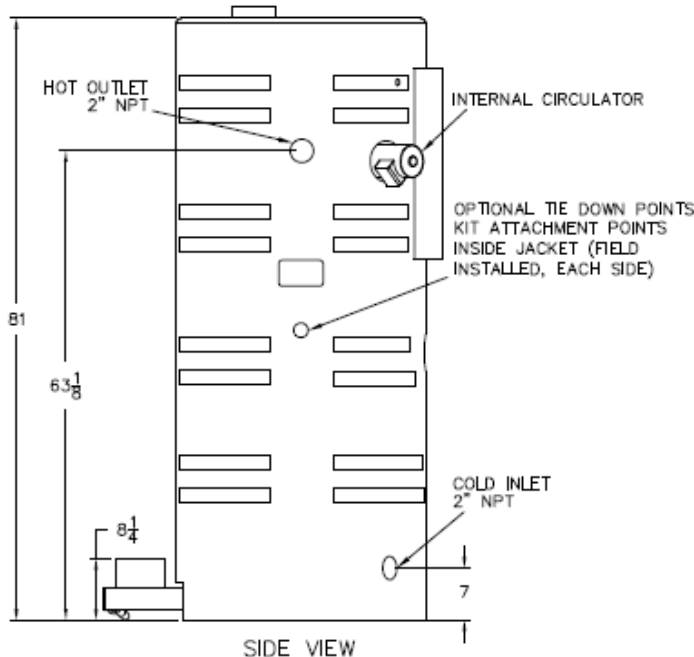

NOTES:

- THE STANDARD PRODUCT OFFERING WILL COME WITH ONE T&P VALVE. FOR THE CSA RELIEF VALVE OPTION, A SECOND RELIEF VALVE WILL BE PROVIDED AS SHOWN.



Hot Water Solutions

PVI Industries | Fort Worth, TX
T: (817) 335-9531 | Toll Free: (800) 784-8326 | PVI.com