

Electrical Power Design Guide

Centurion Water Heaters with Edge[®] Controller

Natural Gas Modulating & Condensing
Water Heater Model CEN 1600 & 2000

Other documents for this product include:

- OMM-0153 Centurion Installation, Operation & Maintenance Manual
- TAG-0102 Centurion Venting & Combustion Air Design Guide
- TAG-0103 Centurion Gas Supply Design Guide

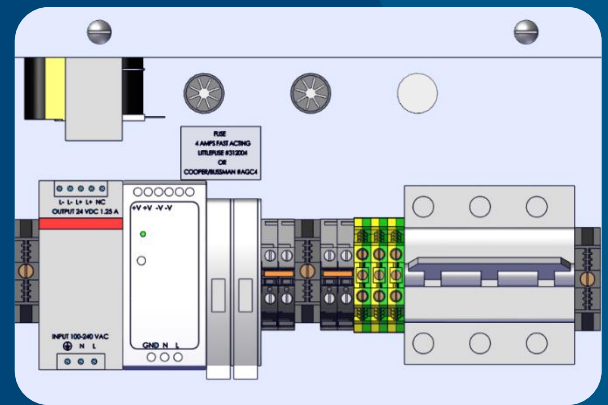

Disclaimer

The information contained in this manual is subject to change without notice from PVI Industries, LLC. PVI makes no warranty of any kind with respect to this material, including, but not limited to, implied warranties of merchantability and fitness for a particular application. PVI is not liable for errors appearing in this manual, not for incidental or consequential damages occurring in connection with the furnishing, performance, or use of these materials.



Manufacturing ASME Commercial Water Heaters Since 1961

PVI Industries, LLC • Fort Worth, TX
USA: T: (817) 335-9531 • Toll Free: (800) 784-8326 • PVI.com
Technical Support • (800) 433-5654 (ext. 3) • Mon-Fri, 8 am - 5 pm CST

1. GENERAL

Centurion natural gas fueled modulating and condensing water heaters are fully factory wired packaged units which require simple external power wiring as part of the installation (Figure 1). This technical guide is intended to help designers provide electrical power wiring (line voltage) to Centurion units. Control wiring details are provided in other publications, depending upon unit application. This document is intended only as a guide and therefore cannot include all possible alternatives or unit applications. In order to comply with all codes and authorities having jurisdiction, designers and installers must plan the electrical wiring carefully and execute the installation completely. Emergency shutoffs, fusible fire switches, break glass stations, and other electrical requirements should be considered and installed whenever necessary.

2. HEATER ELECTRICAL REQUIREMENTS

Centurion water heaters are available with the following power options:

Model	Voltage	Phase	MOCAP Amperage
CEN 1600 - 2000	208 V	3Ø / 60 Hz	20
	460 V	3Ø / 60 Hz	15

Voltages lower than those specified in the table above will result in increased wear and premature failure of the blower motor. Wire size and type should be made per the National Electrical Code based on length and load.

The power box for field wiring connections is located in the upper right corner behind the unit front panel. All copper wire must be connected to the power box.

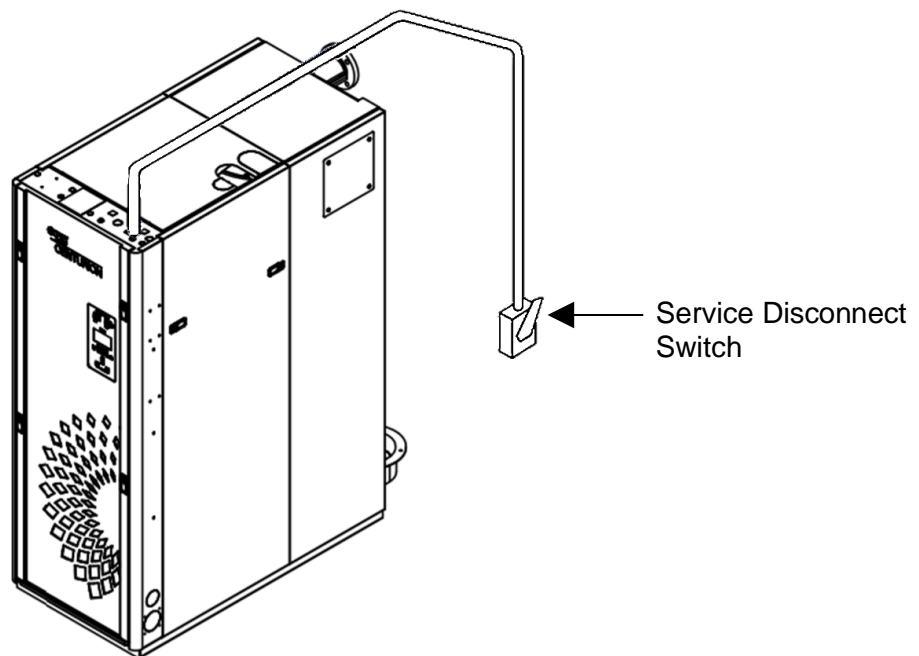

Figure 2-1: Service Disconnect Switch Typical Location

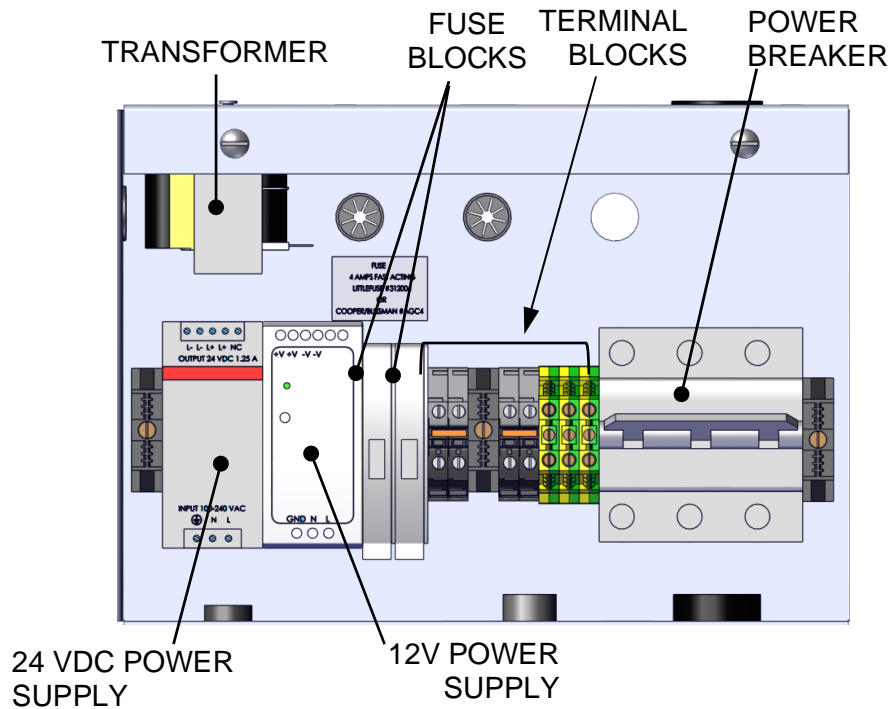

Figure 2-2: Electrical Power Panel Internal Components

3. PROVISIONS FOR SERVICE

Designers must provide emergency shutoffs and other devices to satisfy electrical codes. It is also recommended to provide an electrical shutoff disconnect switch of suitable load carrying characteristics on or near each Centurion water heater.

- No electrical boxes or field components should be mounted to the surface of the unit or where they might interfere with the removal of the side or top panels for maintenance.
- The service disconnect switch should be mounted near the unit (Figure 2-1).
- Wiring conduit, EMT, or other wiring paths should be supported externally, not secured to the unit.
- Electricians should be instructed as to where the wiring conduit should be located, such as away from the relief valve discharge, drains, etc.
- All electrical conduit and hardware should be installed so that it does not interfere with the removal of any covers, inhibit service or maintenance, or prevent access between the unit and walls or another unit.

4. WATER HEATER WIRING

A dedicated protected circuit should be provided from the power source to the water heater. No other electrical devices should be permanently wired on the same circuit. The protected circuit and circuit breaker switch must be sized for the amperage values below.

An emergency switch (electrical shutoff) must be wired in series with power to the unit. Connecting an emergency shutoff switch (E-stop) to the main power terminals of the water heater is the recommended and safest way to totally disable and un-power the unit. Use of the remote interlock, located on the I/O board, is not recommended since it does **not** cutoff power within the unit, it only disables it. Under no circumstance should the remote interlock of the WHM Manager unit be used as an emergency switch for the plant.

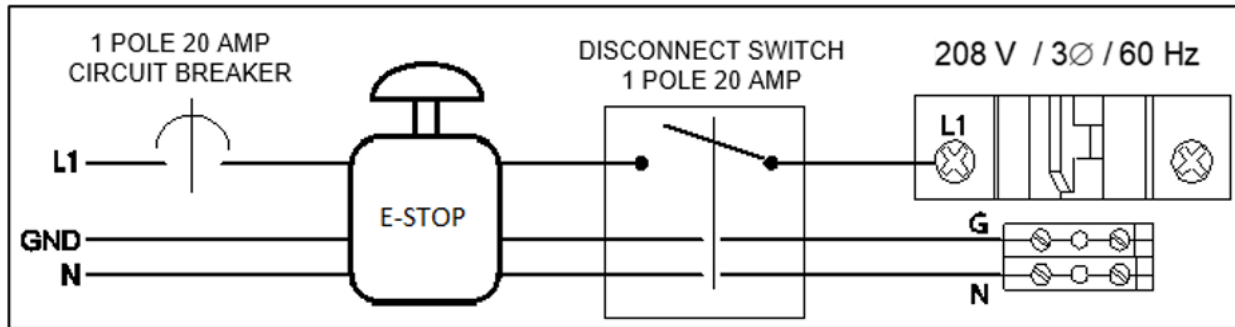

Figure 4-1 – Water Heater Wiring Diagram

The following table lists the input power requirements for all Centurion water heaters, including the diagram number of each model's corresponding schematic diagram:

Diag.	Voltage/Phase/Frequency	MOCP	Wires
1	208V / 3Ø / 60 Hz	20 A	4
2	460V / 3Ø / 60 Hz	15 A	4

For applicable wiring connections, refer to the schematic diagrams below.

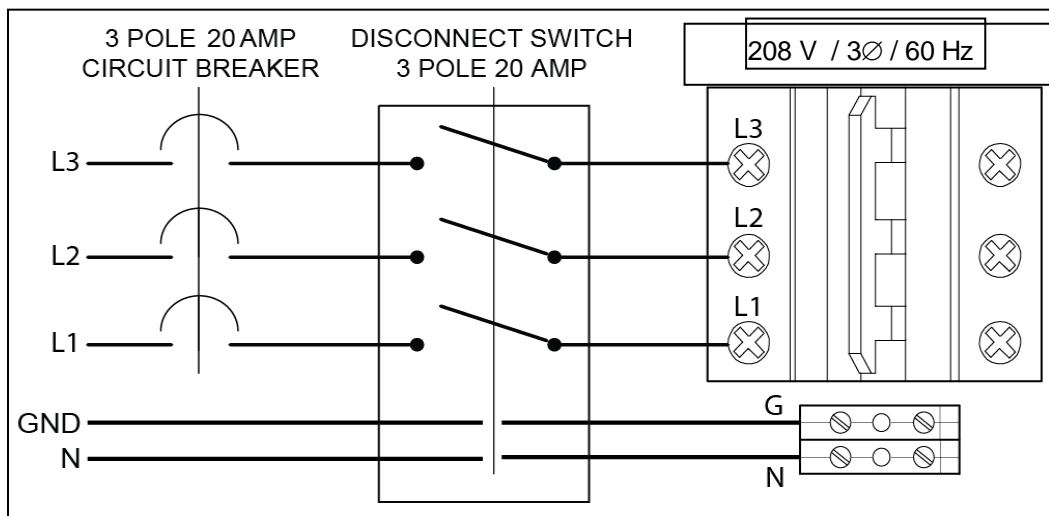

Figure 4-2 – CEN1600/2000: 208 V / 3Ø / 60 Hz - 5 Wire

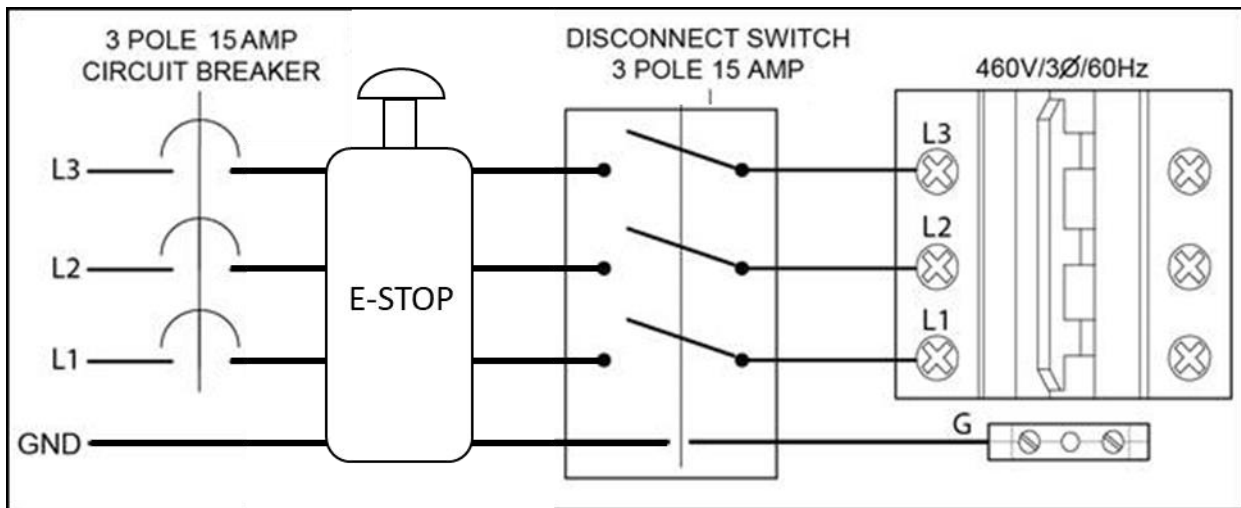

Figure 4-3 - CEN1600/2000: 460 V / 3Ø / 60 Hz - 4 Wire – DOMESTIC

5. MULTIPLE UNIT WIRING

Whenever multiple units are installed within the same mechanical spaces, electrical code requirements call for a single electrical shutoff for emergency use. It is the responsibility of the electrical designer to comply with local codes and regulations affecting an individual installation.

Change Log:

Date	Description	Changed by
------	-------------	------------



© PVI Industries, LLC, 2023