

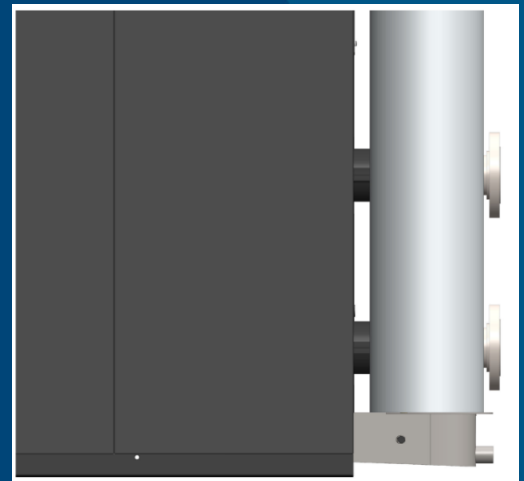
## Venting & Combustion Air Design Guide

# Centurion Water Heaters with Edge<sup>®</sup> Controller

Natural Gas Modulating & Condensing  
Water Heater Model CEN2000

### Other documents for this product include:

- OMM-0153 Centurion Installation, Operation & Maintenance Manual
- TAG-0103 Centurion Gas Supply Design Guide
- TAG-0104 Centurion Electrical Power Guide



### Disclaimer

The information contained in this manual is subject to change without notice from PVI Industries, LLC. PVI makes no warranty of any kind with respect to this material, including, but not limited to, implied warranties of merchantability and fitness for a particular application. Some states do not allow the exclusion or limitation of incidental or consequential damages, so the above limitation may not apply. PVI is not liable for errors appearing in this manual, not for incidental or consequential damages occurring in connection with the furnishing, performance, or use of these materials.



Manufacturing ASME Commercial Water Heaters Since 1961

PVI Industries, LLC • Fort Worth, TX  
USA: T: (817) 335-9531 • Toll Free: (800) 784-8326 • PVI.com  
Technical Support • (800) 433-5654 (ext. 3) • Mon-Fri, 8 am - 5 pm CST

© 2024 PVI, a Watts Brand



**CONTENTS**

**CONTENTS 2**

**1. FOREWORD .....3**

**2. APPROVED VENT MATERIALS .....4**

**3. CODE REQUIRED VENT TERMINATIONS .....5**

**4. COMBUSTION AIR SUPPLY .....6**

4.1 COMBUSTION AIR QUALITY ..... 6

4.2 COMBUSTION AIR FROM WITHIN BUILDING..... 7

4.3 COMBUSTION AIR FROM OUTSIDE BUILDING..... 7

4.4 TWO-PERMANENT-OPENINGS METHOD (USA ONLY) ..... 8

4.5 ONE PERMANENT OPENING METHOD.....10

4.6 OPENING A LOUVER THROUGH THE CENTURION WATER HEATER .....11

4.7 DUCTED COMBUSTION AIR.....11

4.8 EXHAUST VENT AND COMBUSTION AIR SYSTEMS .....11

4.9 GROSS NATURAL DRAFT .....12

**5. ACCEPTABLE PRESSURE RANGES .....13**

**6. EXHAUST FANS .....13**

**7. CORRECTIONS FOR ALTITUDE .....13**

**8. MANIFOLDED SYSTEMS .....13**

**9. ELBOW QUANTITY AND SEPARATION .....13**

**10. EXHAUST MUFFLER GUIDELINES .....14**

**11. VENT & COMBUSTION AIR SYSTEM REQUIREMENTS .....15**

**12. CONDENSATE REMOVAL.....17**

**13. INDIVIDUALLY VENTED SYSTEMS.....18**

13.1 CEN2000 EXAMPLE ..... 18

**14. MANIFOLDED DUCTED COMBUSTION AIR .....20**

14.1 INSTALLATION REQUIREMENTS FOR VERTICAL VENTING .....24

**15. COMMON VENT BREECHING (MANIFOLDED).....25**

**16. PRESSURE DROP AND DRAFT DATA TABLES.....27**

16.1 DISCHARGE FLUE VENT PRESSURE DROP .....27

16.2 DUCTED COMBUSTION AIR DUCT PRESSURE DROP .....27

16.3 GROSS NATURAL DRAFT .....30

16.4 ALTITUDE CORRECTION .....32

16.5 ROUND VS SQUARE DUCT.....33

FOREWORD

**1. FOREWORD**

The **PVI Centurion** natural gas fueled modulating and condensing water heater represents a true industry advance to meet the needs of today's energy and environmental concerns. Designed for application in any water heating system, the Centurion's modulating capability relates energy input directly to fluctuating system loads. Centurion models provide extremely high efficiency operation and are ideally suited for modern low temperature, as well as conventional, water heating systems.

Centurion models operate within the following input and output ranges:

Centurion Water Heater Intake and Output Ranges				
MODEL	INPUT RANGE (BTU/HR.)		OUTPUT RANGE (BTU/HR.)	
	MINIMUM	MAXIMUM	MINIMUM	MAXIMUM
<b>CEN2000</b>	100,000 (29.3 kW)	2,000,000 (586 kW)	95,000 (27.8 kW)	1,920,000 (563 kW)

The output of Centurion Water Heaters is a function of the unit's firing rate (valve position) and return water temperature.

When installed and operated in accordance with this Instruction Manual, the Centurion complies with the NOx emission standards outlined in: **South Coast Air Quality Management District (SCAQMD), Rule 1146.2.**

Whether used in singular or modular arrangements, Centurion Water Heaters offer the maximum venting flexibility with minimum installation space requirements. Centurion Water Heaters are Category II and IV, positive pressure appliances. Single and/or multiple breached units are capable of operation in the following vent configurations:

- Room Combustion Air:
  - Vertical Discharge
  - Horizontal Discharge
- Ducted Combustion Air:
  - Vertical Discharge
  - Horizontal Discharge

Centurion Water Heaters are capable of being vented utilizing PVC, CPVC, Polypropylene and AL29-4C vent systems.

The advanced electronics in Centurion Water heaters are available in several selectable modes of operation offering efficient operation and energy management system integration.

APPROVED VENT MATERIALS

**2. APPROVED VENT MATERIALS**

The Centurion Water Heater is a Category II and IV or Type BH appliance, which require special attention to exhaust venting and combustion air details. The exhaust vent MUST be UL listed for use with Category II and IV appliances. The following materials are allowed:

- Centurion water heaters can use PVC, CPVC or Category II or IV UL1738 or Type BH under ULCS636 listed Polypropylene and Stainless-Steel vent materials.
- PVI recommends the use of Stainless Steel and Polypropylene as the preferred venting material for Centurion water heaters.
- Where codes allow, PVC and CPVC may be used.
- Stainless Steel venting thickness should conform to the following thicknesses:

Diameter	8"	9" to 16"	18" to 24"	26" to 30"
Material Thickness in Inches (mm)	0.015 (0.38)	0.020 (0.51)	0.024 (0.61)	0.034 (0.86)

It is the responsibility of the design engineer and installing contractor to ensure all vent system designs and installations follow industry best practices, including proper pitch, support, and drainage to prevent failure. While UL is the industry standard guideline for venting, it is highly recommended that exhaust vent passing through confined or enclosed building spaces be made of AL29-4C as the most corrosion resistant vent material currently available.

Proper clearances to combustibles must be maintained per UL and the vent manufacturer requirements. The UL, National Fuel Gas Code (ANSI Z223.1/ NFPA54)<sup>1</sup> and CSA B149.1-10 guidelines are often the basis for state and local codes. PVI’s recommendations follow the guidelines of these agencies, unless more stringent codes govern the installation site. The venting and combustion air systems must meet all applicable code requirements.

All Canada installations must comply with CSA B149.1 installation code.



**Figure 2-1 Exhaust Vent Adapter 8" (204mm) for PVC/CPVC Kit # 24786**

**CODE REQUIRED VENT TERMINATIONS****3. CODE REQUIRED VENT TERMINATIONS**

The guidelines provided in this bulletin should be followed to comply with PVI, UL, NFPA 54 (National Fuel Gas Code, ANSI Z223.1) and in Canada: CSA B149.1-10 recommendations and regulations.

Vent terminations must be at least **4 feet (1.22 m)** below, **1 foot (0.30 m)** above or **4 feet (1.22 m)** removed horizontally from any window, door or gravity air inlet of a building. Such terminations must extend beyond the outside face of the wall by at least **6 inches (15.2 cm)**.

The bottom of the vent termination must be at least **12 inches (30.5 cm)** above both finished grade and any maximum snow accumulation level to avoid blocking the vent or air intake. The vent termination must be least **3 feet (0.91 m)** above any forced-air building inlet within **10 feet (3.05 m)**. Design must prevent flue gases from recirculating through the air intake.

Vents must not terminate over public walkways or areas where condensate or vapor could create a nuisance or be detrimental to the operation of regulators, meters or related equipment.

Discharges must not be in high wind areas or corners, or be located directly behind vegetation. Discharges in these locations may cause the flue pressures to fluctuate and result in flame instability. Generally, designs should minimize wind effects.

Wall and roof penetrations must follow all applicable codes and the vent manufacturer's instructions. Vents must never be installed at less than required clearances to combustible materials, as enumerated in UL, NFPA, CSA B149.1-10 or local codes "Double-wall" or "Thimble" assemblies are required when vents penetrate combustible walls or roofs.

Vertical discharges must extend at least **3 feet (0.9 M)** above the roof through properly flashed penetrations, and at least **2 feet (0.61 m)** above any object within a **10 foot (3.05 m)** horizontal distance.

Large-mesh screens can be applied to the vent termination to protect against the entry of foreign objects, but the "free area" should be at least 50% larger than the required flue cross-sectional area preceding the vent termination. It is recommended that a T termination be used if a screen is desired. Do not use mesh screens on velocity cones.

If the vent system is to be connected to an existing stack, the stack must be UL listed for Category II and IV appliances (capable of **280 °F (138 °C)**, positive pressure and condensing flue gas operation). Masonry stacks must be lined, and the vent penetration must terminate flush with, and be sealed to, this liner. Vents may enter the stack through the bottom or side. All side connections must enter at a 45-degree connection in the direction of flow and must enter at different elevations, with the smallest vent connection at the highest elevation. Centurion vents must not be connected to another manufacturer's equipment.

The exhaust vent must be pitched upward toward the termination by a minimum of **¼ inch per foot (21 mm per m)** of length. Condensate must flow back to the unit freely, without accumulating in the vent.

## 4. COMBUSTION AIR SUPPLY

Centurion Water Heaters require the following combustion air volumes at full capacity:

UNIT	VOLUME at 60°F (15.6°C)	Air Inlet Adapter Size
CEN2000	500 SCFM (14.16 L/min)	8 inches

These flows **MUST** be accommodated. Air supply is a direct requirement of NFPA, CSA B149.1-10 (Canada) and local codes should be consulted for correct design implementation.

Combustion air typically enters through the inlet on the right side of the unit. An identical opening with cover plate is on the left side. Centurion units have the option of installing an 8" Side Air Inlet Adapter Kit, part number **39184-1**.

### CAUTION

The unit does not utilize sealed combustion.

### 4.1 COMBUSTION AIR QUALITY

In equipment rooms containing other air-consuming equipment — including air compressors and other combustion equipment — the combustion air supply system must be designed to accommodate all such equipment when all are operating simultaneously at maximum capacity.

### WARNING!

Combustion air must be free of contaminants.

Combustion air intakes must be located in areas that will not induce excessive (>0.10" W.C. (25 Pa)) intake air pressure fluctuations. Designers should consider equipment blowers and exhausts when using room air for combustion.

Air intakes must be located to prevent infiltration of chlorine, chlorides, halogens or other chemicals detrimental to the equipment. This will ensure the longevity of the equipment and maintain warranty validation. Common sources of these chemicals are swimming pools, degreasing compounds, water softener salts, plastic processing and refrigerants.

### WARNING!

Equipment rooms in the vicinity of these types of chemicals must be supplied with clean combustion air; a supply air fan is required if any contaminants are likely to be present. If supply air fans are used, individual duct pressure should be maintained between 0.05" to 1.0" W.C. to minimize the impact on combustion.

The equipment room and heater enclosure should have positive room air pressure provided by a powered combustion air supply louver or duct, to prevent infiltration of chemicals.

Air intakes must not be in the proximity of garages, industrial and medical hood venting, loading docks or refrigerant vent lines. Water heaters must not be installed in proximity to activities that generate dust if that dust can enter the air intake. Water heaters must be located to prevent moisture and precipitation from entering combustion air inlets.

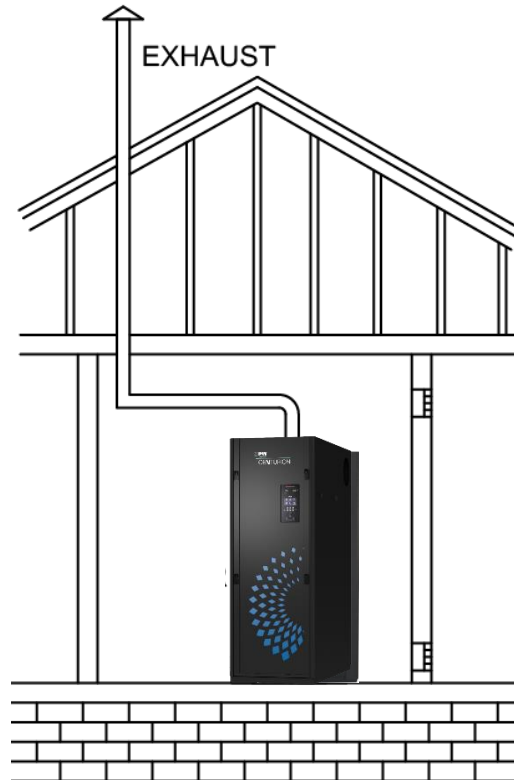
When a unit is used to provide heat during construction or renovation, accumulated drywall dust, sawdust and similar particles can accumulate in the combustion air intake and burner surface, potentially blocking combustion air flow and restricting the air/fuel mixture. In these situations, PVI requires that a disposable air intake filter be installed, temporarily, above the combustion air inlet. Air filters may be required year-round in instances in which dust or debris can enter the combustion air tube. Consult OMM-0153 for details.

Combustion air temperatures as low as **-30 °F (-34.4 °C)** can be used without affecting the integrity of the equipment; however, the combustion settings may require adjustment to compensate for site conditions.

## 4.2 COMBUSTION AIR FROM WITHIN BUILDING

Where combustion air will originate from within the building, air must be provided to the equipment room from two permanent openings to an interior room (or rooms). Openings that connect indoor spaces must be sized and located in accordance with the following:

- Each opening must have a minimum free area between **1 inch<sup>2</sup> per 1,000 BTU/hr. (2,200 mm<sup>2</sup>/kW)** of total input rating of all appliances, but not more than **100 inch<sup>2</sup> (0.06 m<sup>2</sup>)**.
- One opening must commence within **12 inches (300 mm)** of the top of the enclosure, and one opening must commence within **12 inches (300 mm)** of the bottom.



**Figure 4-1: All Combustion Air from Adjacent Indoor Spaces through Indoor Combustion Air Openings**

## 4.3 COMBUSTION AIR FROM OUTSIDE BUILDING

Outdoor combustion air must be provided through opening(s) to the outdoors in accordance with the methods described below. The minimum dimension of air openings must not be less than **3 inches (76 mm)**. The required size of the openings for combustion air must be based upon the net free area of each opening. When the free area through a louver, grille, or screen is known, it must be used to calculate the opening size required to provide the free area specified. For additional details, consult NFPA 54, or in Canada, CSA B149.1-10, paragraphs 8.4.1 and 8.4.3.

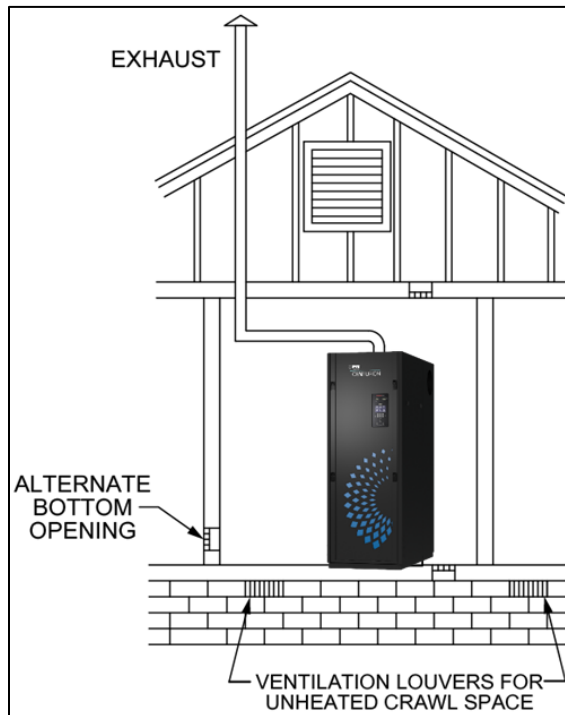


SECTION 4 - START SEQUENCE

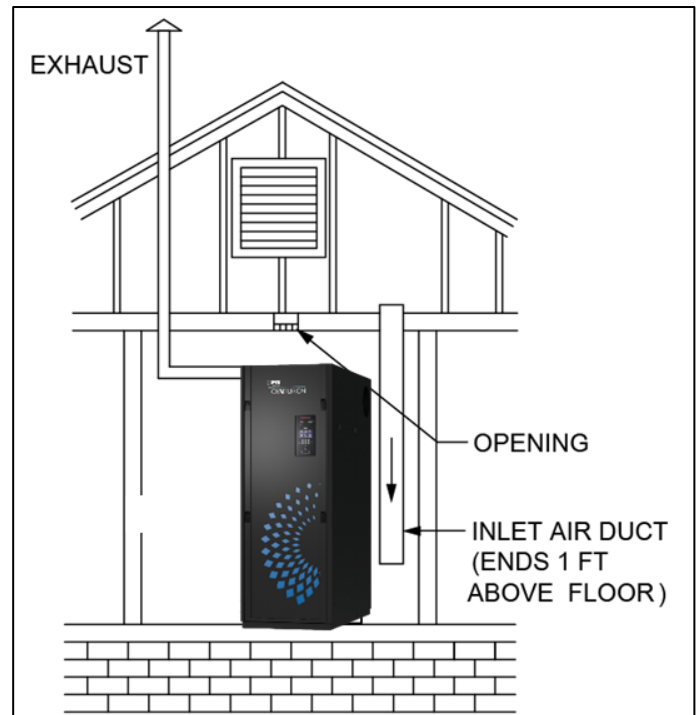
**4.4 TWO-PERMANENT-OPENINGS METHOD (USA ONLY)**

Two permanent openings must be provided: one commencing within **12 inches (304 mm)** of the top of the enclosure and one commencing within **12 inches (304 mm)** of the bottom. The openings must communicate directly — or by ducts — with the outdoors, or spaces that freely communicate with the outdoors, as show below:

1. When communicating directly with the outdoors, or when communicating to the outdoors through vertical ducts, each opening must have a minimum free area of **1 inch<sup>2</sup> per 4,000 BTU/hr. (550 mm<sup>2</sup>/kW)** of total input rating of all appliances in the space.



**Figure 4-2: All Combustion Air from Outdoors - Inlet Air from Ventilated Crawl Space and Outlet Air to Ventilated Attic**

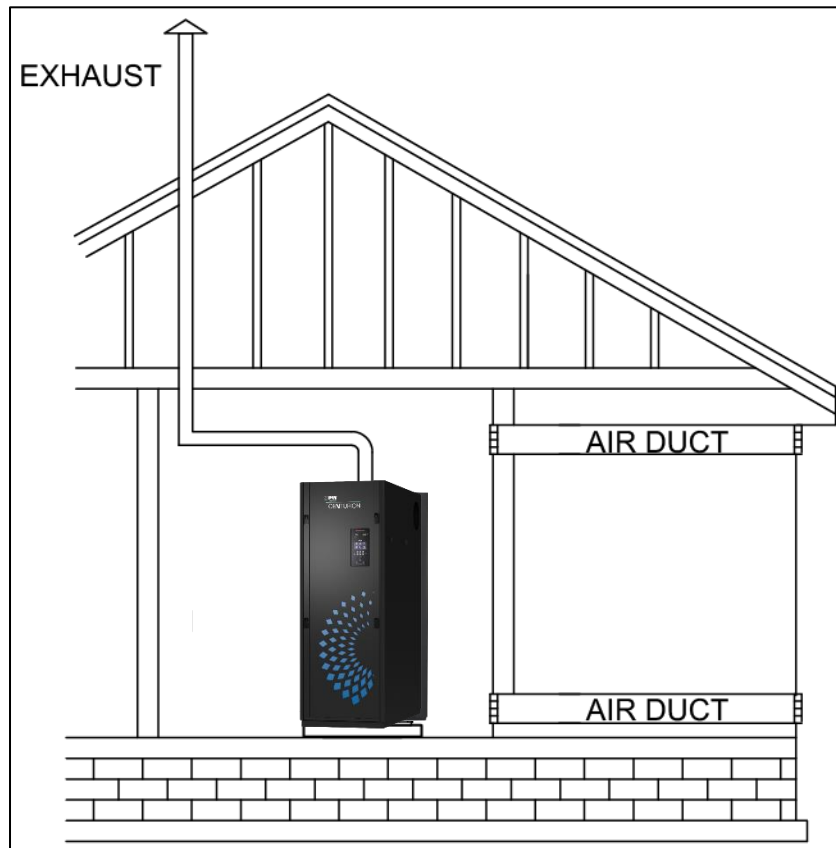


**Figure 4-3: All Combustion Air from Outdoors - Through Ventilated Attic**



SECTION 4 - START SEQUENCE

2. When communicating with the outdoors through horizontal ducts, each opening must have a minimum free area of **1 inch<sup>2</sup> per 2,000 BTU/hr. (1100 mm<sup>2</sup>/kW)** of total input rating of all appliances in the space.

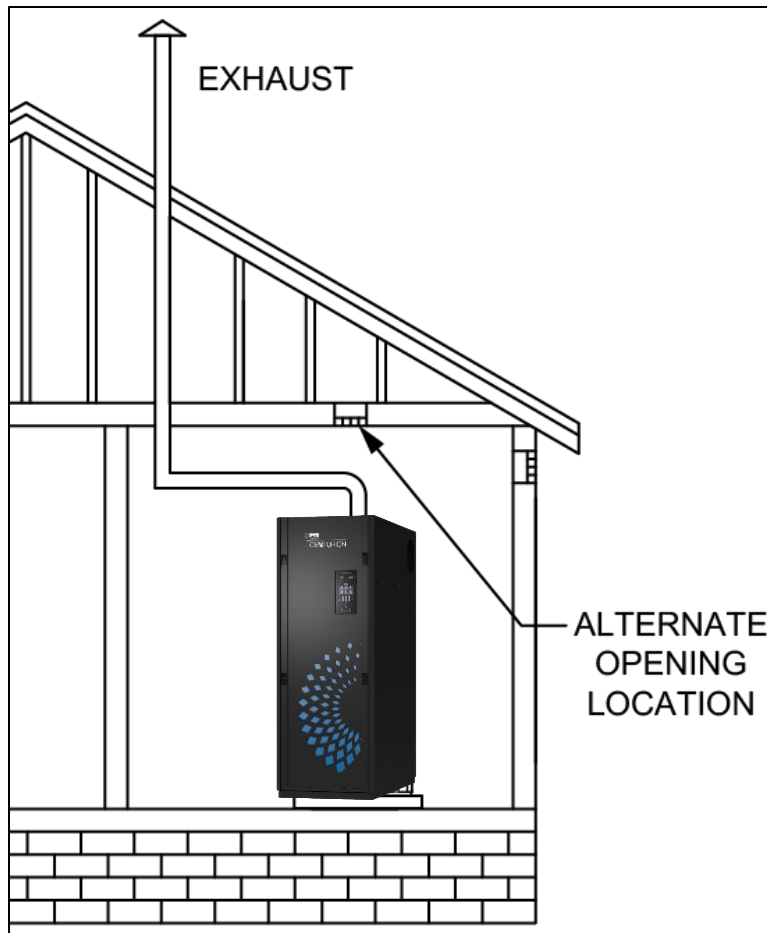


**Figure 4-4: All Combustion Air from Outdoors Through Horizontal Ducts**

#### 4.5 ONE PERMANENT OPENING METHOD

One permanent opening must be provided, commencing within **12 inches (300 mm)** of the top of the enclosure. The appliance must have clearances of at least **1 inch (25 mm)** from the sides and back of the appliance, and a clearance of 6 inches (150 mm) from the front. The opening must communicate directly or through a vertical or horizontal duct to the outdoors or spaces that freely communicate with the outdoors and must have a minimum free area as follows:

- **1 inch<sup>2</sup> per 3,000 BTU/hr. (700 mm<sup>2</sup>/kW)** of the total input rating of all appliances located in the space.



**Figure 4-5: All Combustion Air from Outdoors Through Single Combustion Air Opening**

#### **4.6 OPENING A LOUVER THROUGH THE CENTURION WATER HEATER**

A louver can be opened using the Centurion's auxiliary relay contacts. These contacts are provided by a single pole double throw (SPDT) relay that is energized when there is a demand for heat and is de-energized after that demand is satisfied. The relay contacts are rated for 120 VAC at 5 amps, resistive.

**NOTE:** Do NOT power the louver directly using the Auxiliary Relay. An external relay must be employed for this purpose. The heater power cannot support external accessories.

If the louver features a proof-of-open switch, it must be connected to the unit's delayed interlock which must be closed for the unit to fire. If the louver requires time to open, a time-delay must be programmed to hold the start sequence of the heater long enough for the proof-of-open switch to make (Parameter: **Aux Start On Delay** — programmable from 0 to 120 seconds). If the proof-of-open switch does not prove within the programmed time frame, the unit will shut down.

For wiring connections and further details regarding the auxiliary relay, delayed interlock and the **Aux Start On Delay** parameter, refer to OMM-0153.

#### **4.7 DUCTED COMBUSTION AIR**

Centurion is approved for ducted combustion air installations, i.e., it can draw all combustion air from the outdoors through a metal or PVC duct connected between the Centurion unit(s) and the outdoors. This configuration is useful for situations in which room air is insufficient or otherwise unsuitable for combustion. The minimum ducted combustion-air duct sizes for Centurion water heater is 8-inch diameter (20.3 cm) BMK750 = 6-inch diameter (15.2 cm).

In many installations, the combustion air duct can be manifolded for multiple unit applications.

The length and restriction of the combustion air duct directly impacts the size, length and restriction of the discharge venting. The ducted air intake must be located at least **3 feet (0.9 m)** below any vent termination within **10 feet (3.1 m)**.

A screen with mesh size not smaller than **1" x 1" (25.4 mm x 25.4 mm)** must be installed at the inlet of the ducted combustion air duct.

#### **IMPORTANT!**

Please consult your local PVI representative or the PVI factory for all applications utilizing common ducted combustion air with common breeching of exhausts.

Other configurations, not depicted in this guide, are possible. If you intend to implement any of these options, please contact your local PVI representative or the PVI factory for project specific venting and combustion air configurations.

#### **4.8 EXHAUST VENT AND COMBUSTION AIR SYSTEMS**

Centurion supports several venting and combustion air options, and although the application parameters vary, there are basic similarities among all systems. Sections 24.1 and 24.2 of this Guide provide tables that address the pressure drop of most applicable vent and duct fittings and sizes. The losses in the vent exit and air duct entrance are also included.

It should be noted that flow and vent or duct diameter have the most significant effects on overall system pressure drop. When using fittings or terminations not listed in the Tables in Section 24, consult the device manufacturer for actual pressure drop values. If a rectangular duct is to be used, consult the table in Section 24.5 for a round diameter duct size that has the identical pressure drop per length of rectangular duct.

## 4.9 GROSS NATURAL DRAFT

Flue gases have a lower density (and are lighter) than air and will rise, creating "gross natural draft." Gross natural draft is created when flue gases exit the vent at an elevation above the Centurion unit. The amount of draft depends upon the height of the stack and the difference between the flue gas temperature and the surrounding air temperatures (densities). Gross natural draft values for stacks at various heights above the Centurion unit are presented in Section 24.3. These draft values are based on an installation site at sea level.

Adding the gross natural draft (negative) to the vent and air system pressure drop (positive) determines if the total system will be positive pressure or negative pressure ("net natural draft"). As with most combustion equipment, negative pressure (net natural draft) systems should be treated differently from positive pressure systems when the discharge vents are manifolded. Note that sidewall vent terminations, as well as some vertical terminations, are positive pressure systems.

***Contact your PVI sales representative or PVI factory for design assistance and approval when designing manifolded exhaust vent systems.***

### CAUTION!

Do NOT install a non-sealed draft control damper.

## 5. ACCEPTABLE PRESSURE RANGES

For individually vented units, the exhaust system must be designed so that pressure measured at every point is in the range from **-0.25" W.C. to +0.81" W.C. (-62 Pa to 202 Pa)**. For common vented units, the exhaust system must be designed so that pressure measured at every point is in the range from **-0.25" W.C. to +0.25" W.C. (-62 Pa to 62 Pa)**. Pressures below **-0.25" W.C. (-62 Pa)** (more negative) may cause flame instability. Pressures above **+0.25" W.C. (62 Pa)** for common vented units, or **+0.81 W.C. (202 Pa)** for individually vented units (more positive), will prevent flue gases from exiting.

## 6. EXHAUST FANS

If the unit's exhaust system incorporates an exhaust fan, the system designer must size the vent pipe diameters, select the fan and determine the location of the fan sensor to maintain a **-0.25" W.C. to +0.25" W.C. (-62 Pa to 62 Pa)** pressure range at the outlet of each boiler. Also, the designer must ensure that the exhaust fan material is acceptable for use with Category IV appliances.

## 7. CORRECTIONS FOR ALTITUDE

The table in Section 16.4 lists correction factors for installation altitudes above sea level. These factors must be applied to both the natural draft and pressure drops of vent and air ducts. *The pressure drop through vents and combustion air ducts will increase at higher elevations, while the natural draft will decrease.*

## 8. MANIFOLDED SYSTEMS

In many instances it may be practical to connect multiple units using a manifolded vent or exhaust configuration. However, when multiple units are connected by a manifolded air intake or exhaust vent, the operation of a given unit can be affected by the others, if the venting or combustion air system is not designed properly. Properly designed common vent and air supply systems can be installed that will prevent "operational interaction" between units.

**Do not use static regain method on common ductwork, but rather, use one duct size for the common run (See Figure 15d).**

***Contact your PVI sales representative or PVI factory for design assistance and review when designing manifolded exhaust and manifolded combustion air systems.***

## 9. ELBOW QUANTITY AND SEPARATION

The quantity and angle of elbows and the distances between them can influence the system's exhaust and combustion air pressures, as well as its acoustic behavior. Designers should consider minimizing the number of elbows and maximizing the distance between them in the layout design. Use of angles less than 90° is recommended whenever possible. Five or fewer elbows are recommended for individual venting runs; five or fewer are similarly recommended for common sections. In flue and combustion air ducting runs, elbows should remain separated as much as possible. Where close elbows cannot be avoided, factory review is recommended to determine if changes need to be made.

## 10. EXHAUST MUFFLER GUIDELINES

An exhaust muffler is recommended when units are installed in a noise-sensitive application and when the exhaust vent ducting is relatively short in length. The following criteria must be used to determine when to include a field-installed muffler:

- The exhaust is **sidewall vented** and the vent is terminated in close proximity to residences, offices, hotel/hospital rooms, classrooms etc.  
**\*\*\*OR\*\*\***
- The **total vertical and horizontal section** of the exhaust vent is **less than 25 linear feet (7.6 m)** in length from the last unit, and the vent terminates in close proximity to residences, offices, hotel/hospital rooms, classrooms etc.



**Figure 10-1: Flanged PVI Exhaust Muffler**

For **manifolded exhaust** systems, the total vertical section length includes both horizontal and common vertical; individual unit vertical connectors are included in the determination as well.

**EXAMPLE:** For an installation that has a **20 foot (6 m)** common vertical, **5 foot (1.5 m)** common horizontal after the last unit, and each unit has a **10 foot (3.1 m)** vertical connector, the total section linear length considered is **35 feet (10.7 m)**. Because this length is greater than **25 linear feet (7.6 m)**, a muffler is **not** required.

**Contact your PVI sales representative for more information on the PVI exhaust muffler.**

## **11. VENT & COMBUSTION AIR SYSTEM REQUIREMENTS**

Minimum exhaust vent and combustion air duct size for Centurion is **8 inches (20.3cm)**.

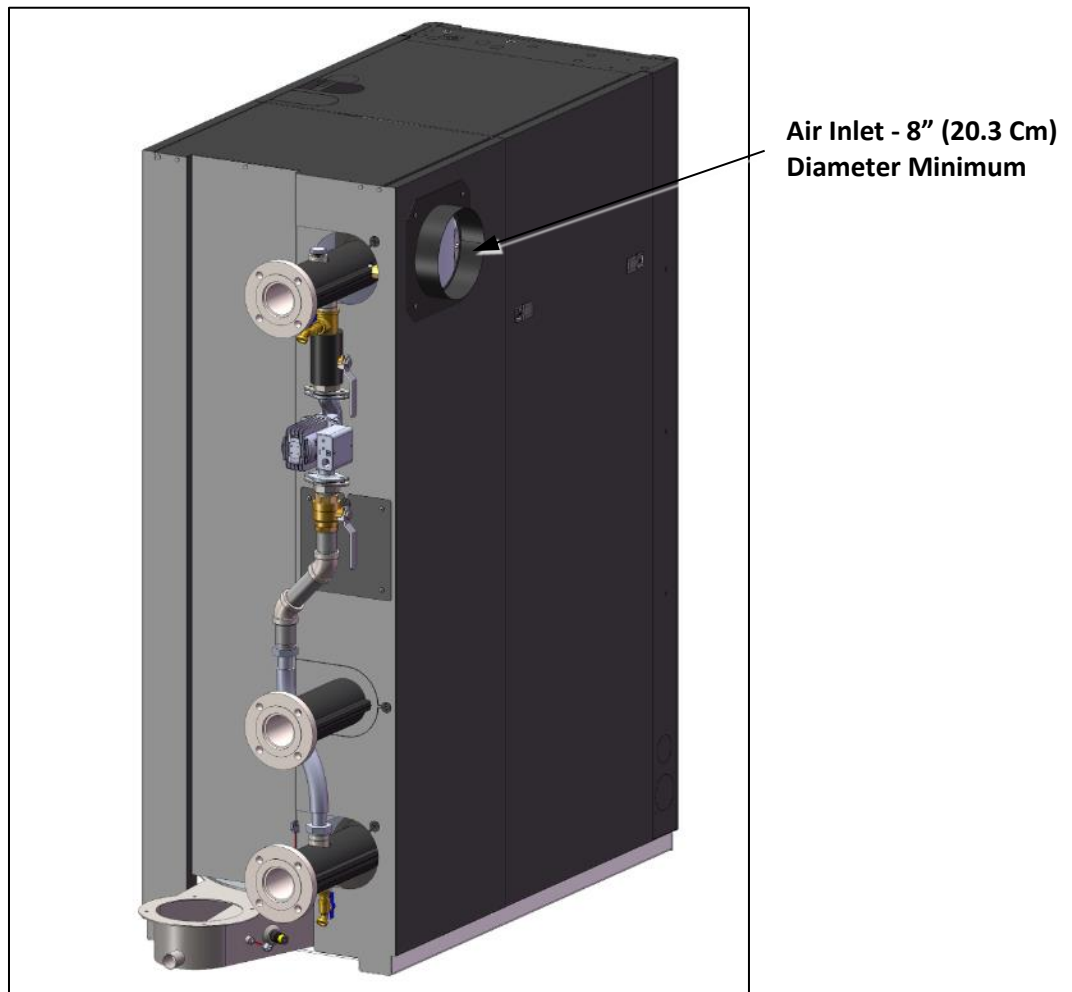
A **1/4-inch (6.35 mm)** NPT combustion test hole is provided on each unit's exhaust manifold connection (see figures below). A **24 inch (61 cm)** length of straight vent is required downstream of the exhaust manifold, as illustrated in these figures.

The vent system should always be pitched up **1/4 inch per foot (21 mm per m)** of run towards the vent termination to enable condensate to drain back to the unit for disposal. Low spots in the vent must be avoided. Periodic inspection must be performed to assure correct drainage.

Exhaust vents must not be interconnected to those of other manufacturers' equipment.

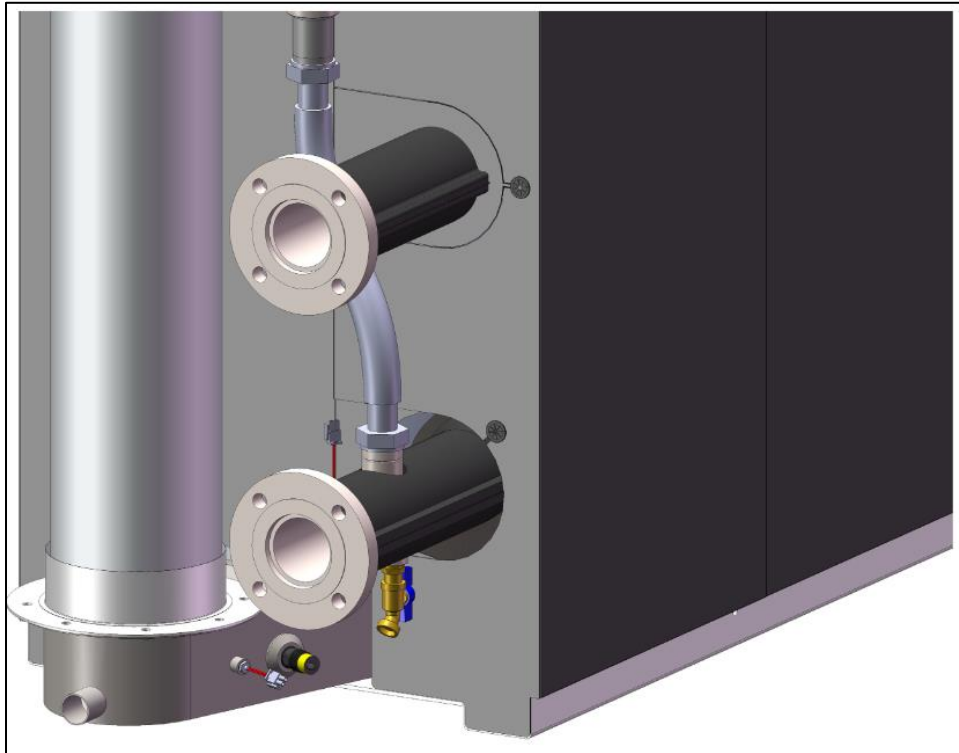
Horizontal vent and ductwork must be supported to prevent sagging, in accordance with local code and the vent manufacturer's requirements. Vertical vent and ductwork must be supported to prevent excessive stress on the horizontal runs. The exhaust manifold and inlet air adaptor must never be used as weight-supporting elements. The supports must be arranged, and the overall layout designed, to assure that stresses on the vent and combustion air connections are minimized.

The vents and combustion air ducts may be insulated in accordance with the vent manufacturer's instructions and local codes.

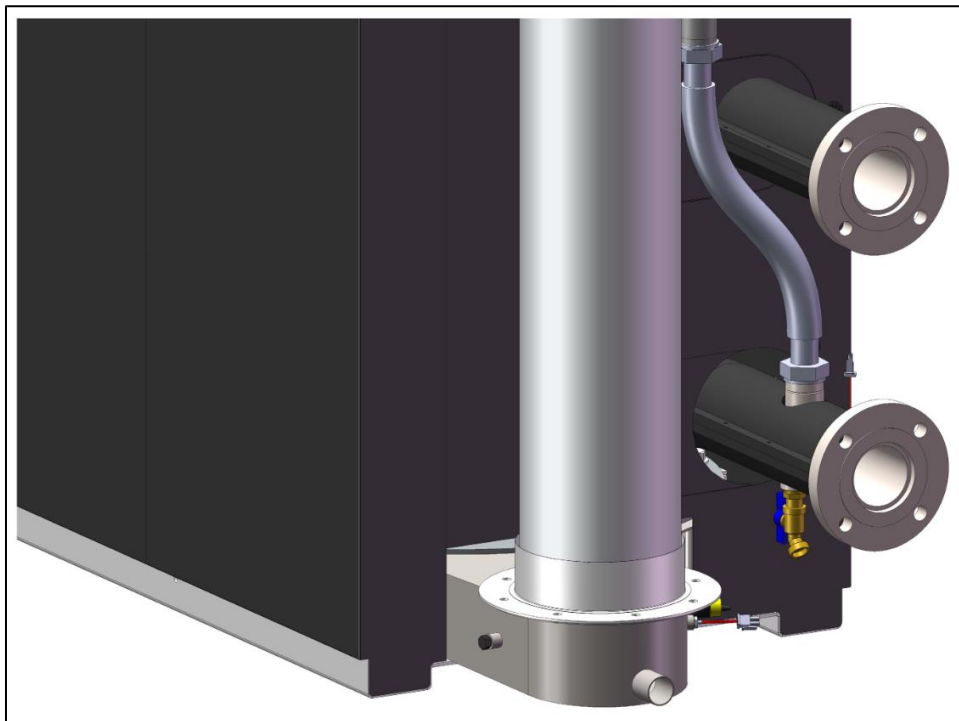


**Figure 11: Rear Air Inlet Adaptor**





**Figure 11a: Rear Sensor**



**Figure 11b: Rear Sensor Port**

## 12. CONDENSATE REMOVAL

The exhaust vent system must be pitched back toward the unit by a minimum of **1/4 inch per foot (21 mm per m)** of duct length to enable condensate to drain back to the unit for disposal. Low spots in the vent must be avoided to prevent the condensate from collecting.

The condensate trap assembly is located directly below the exhaust manifold. Plastic hose must be connected to the trap assembly and run to drain. Care must be taken to avoid hose kinks and to avoid raising the hose above the trap assembly. Condensate must flow freely to drain. The condensate-to-drain run must not be hard-piped so the trap can be removed periodically for maintenance purposes.

If the condensate must be lifted above the trap assembly to a drain, it must be drained into a sump. From there, a pump can lift the condensate away.

Each unit produces the following approximate condensate quantities in full condensing mode:

- CEN2000 = 10 gallons (37.9 L) per hour

Condensate drain systems must be sized for full condensing mode.

In multiple heater applications, it is common to manifold these drains together in a plastic pipe manifold to a floor drain. Condensate manifolds must be large enough to handle the anticipated flow and must be properly secured and protected. Manifolds are generally located behind the boilers so that short runs of plastic tubing into the manifold can be used for the condensate drain. A base drain must be installed at the bottom of vertical common flue piping.

The pH level of the condensate produced by Centurion heaters is acidic and ranges between 3.0 and 3.2. The installation must be designed in accordance with local codes that specify acceptable pH limits. If required, any type of commercially available neutralizer may be used. An optional, field-installed, Condensate Neutralization System is available from the factory.

## 13. INDIVIDUALLY VENTED SYSTEMS

Systems with individual vents may be used with any of the combustion air systems described previously. **The maximum combined pressure drop of the vent and combustion air system must not exceed 140 equivalent feet (42.7 m).**

To calculate the pressure drop:

- 1) Calculate the exhaust vent pressure drop.
- 2) Calculate the combustion duct pressure drop.
- 3) Divide the vent pressure drop by the altitude correction factor (CF) listed in the table in Section 16.4 to correct for installations above sea level.
- 4) Determine any natural draft from table in Section 16.3 and multiply it by the altitude CF.
- 5) Add altitude corrected vent pressure drop (positive) and draft (negative) to get the total vent pressure drop.
- 6) Add total vent pressure drop to the altitude corrected combustion air duct pressure drop.

### 13.1 CEN2000 EXAMPLE

Calculate the maximum pressure drop for a unit installation at 500 feet (150 m) above sea level having a winter design temperature of 20 °F (-6.7 °C). The duct system consists of:

- 1) An 8-inch (20.3 cm) diameter exhaust vent with two (2) 90° elbows, one (1) 45° elbows, 10 feet (3.05 m) of horizontal run, 20 feet (6.1 m) of vertical run;
- 2) A rain cap termination;
- 3) 8-inch (20.3 cm) combustion air duct with two 90° elbows and 15 feet (4.6 m) of run.

**CALCULATION:**

**8-inch Diameter Exhaust Vent Pressure**

Two 90° elbows:	2 x 5.86	= 11.72 ft. (3.57 m)
One 45° elbow:	1 x 4.42	= 4.42 ft. (1.35 m)
30 feet (9.1 m) total run (10 horizontal + 20 vertical):		
	30 x 0.71	= 21.3 ft. (6.49 m)
Rain cap exit loss:	1 x 16.71	= 16.71 ft. (5.09 m)
Vent drop subtotal:		= 54.15 ft. (16.5 m)
Altitude correction:	<u>54.15</u>	= 55.14 ft. (16.8 m)
	0.982 (CF)	
Natural draft for 20 feet (6.1 m) @ 20 °F (-6.7 °C) outside temperature:		
		= -12.6 ft. (-3.84 m)
Altitude correction:	-12.6 x 0.982 CF	= -12.37 ft. (-3.77 m)
<b>Total vent drop:</b>		<b>= <u>42.77 ft. (13.03 m)</u></b>

**8-inch Diameter Combustion Air Duct Pressure**

Two 90° elbows:                    2 x 2.51                    = 5.02 ft. (1.53 m)

15 feet (4.6 m) total run:    15 x 0.43                    = 6.45 ft. (1.97 m)

Entrance loss: 1 x 8.60                    = 4.84 ft. (1.48 m)

Combustion air drop subtotal:                    = 16.31 ft. (4.98 m)

Altitude correction:        = 16.31                    = 16.61 ft. (5.06 m)

0.982 CF

**Combustion air drop total:                    = 16.61 ft. (5.06 m)**

**System total pressure drop**

Vent drop + combustion air duct pressure drop

= **42.77 + 16.61**

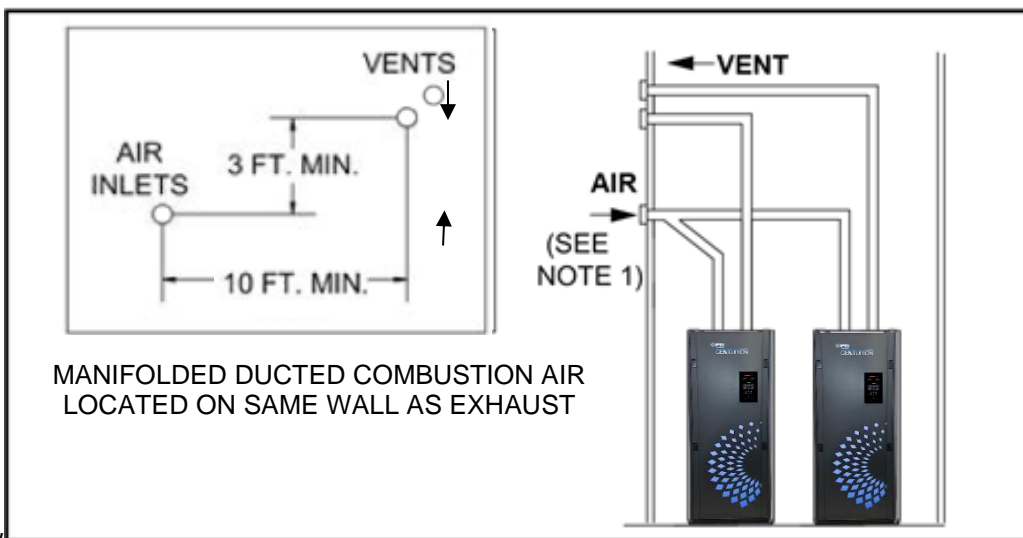
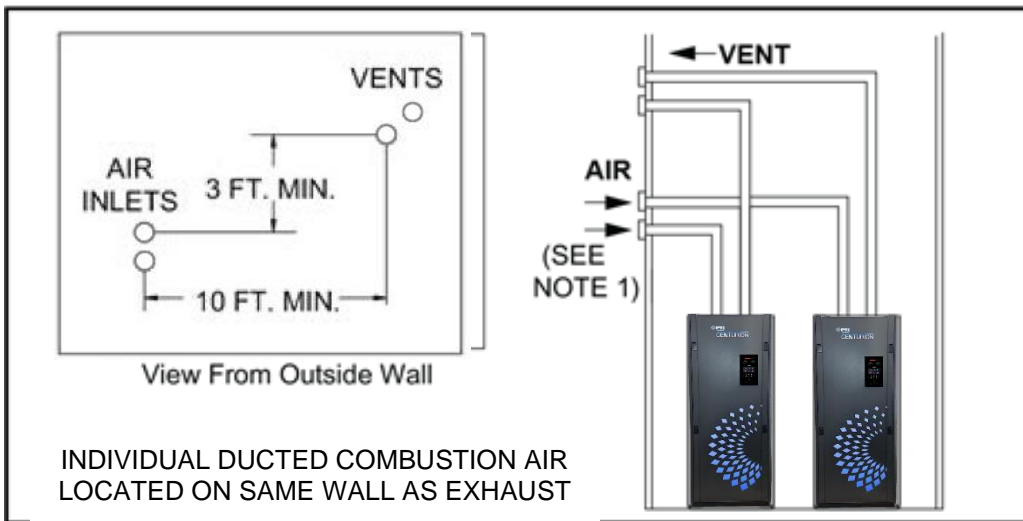
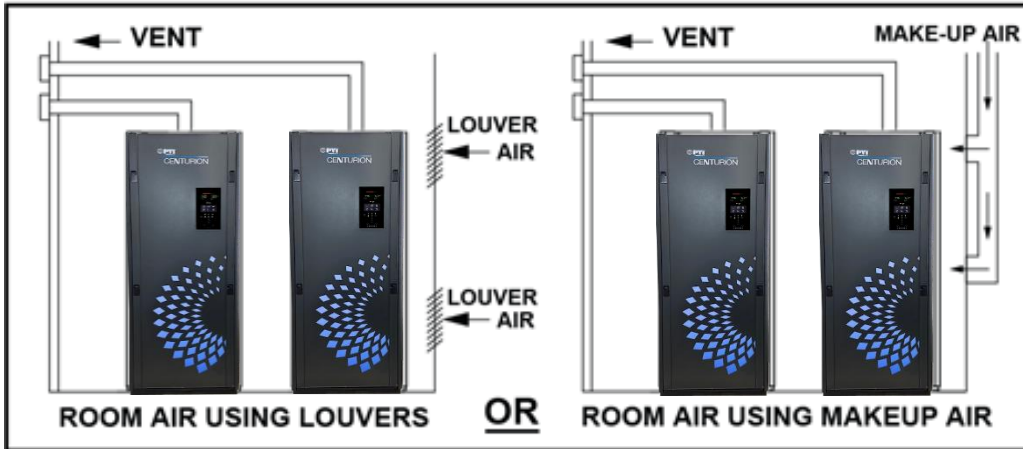
= **59.38 ft. (18.09 m)**

**Conclusion:**

Pressure drop is less than 140 equivalent feet (42.7 m) – **System OK.**

**14. MANIFOLDED DUCTED COMBUSTION AIR**

For systems using manifolded ducted combustion ductwork, use the longest length of common duct and the individual branch to the furthest unit to calculate the pressure drop.

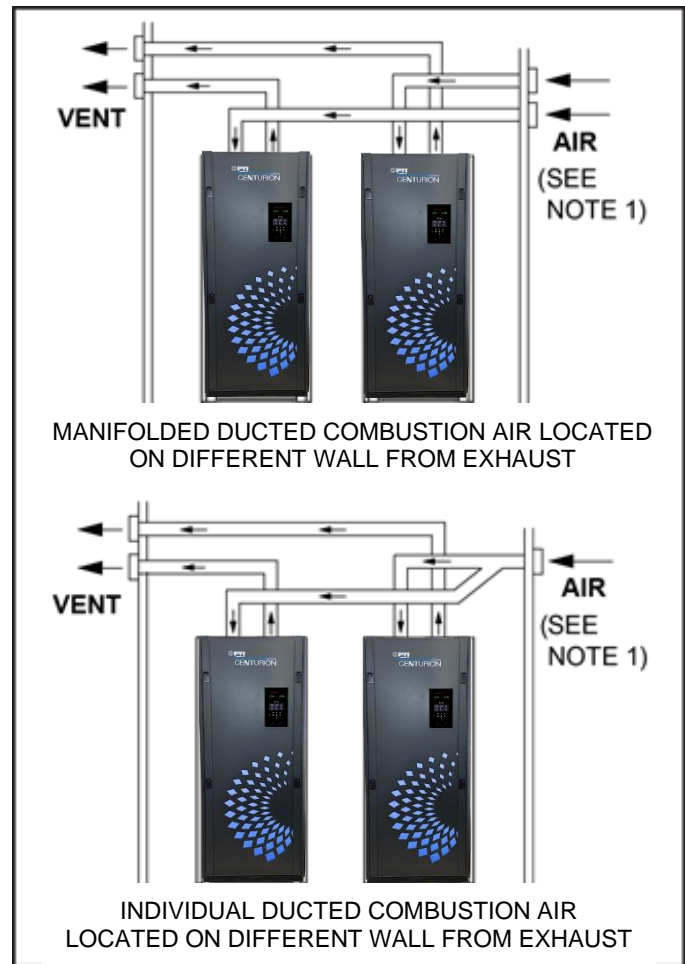


**NOTE:** Do not install flues directly above another flue termination as this can lead to exhaust gas recirculation; refer to NFPA 54 for details on code required vent termination.

**Figure 14a: Individual Vents – Preferred Installations**

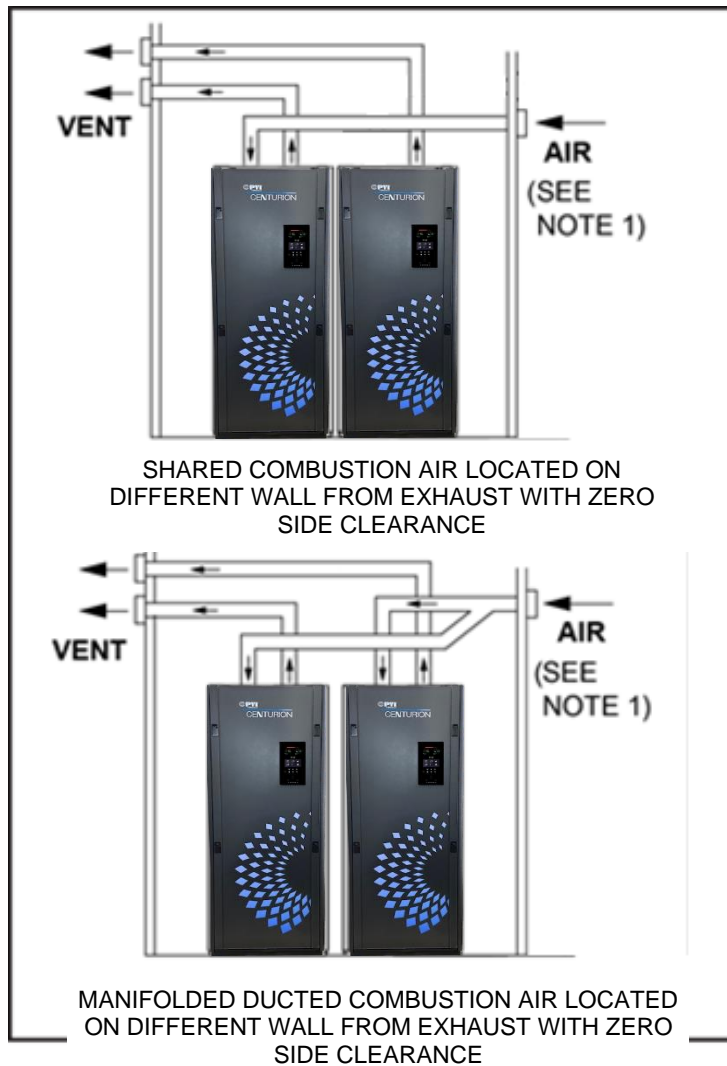
**IMPORTANT:**

- For high wind sites, a tee must be installed at the fresh air inlet. The leg of the tee connects to the combustion air intake.
- On the flue vent side, a tee or exit cone (velocity cone) may be utilized in place of a rain cap for high wind sites.
- The branches of the tee can be in the horizontal or vertical direction, as determined by the system designer and site conditions.
- In cooler climates, flue terminations should be horizontally offset to eliminate ice formation, due to condensate, from blocking the lower exhaust (see diagram below).



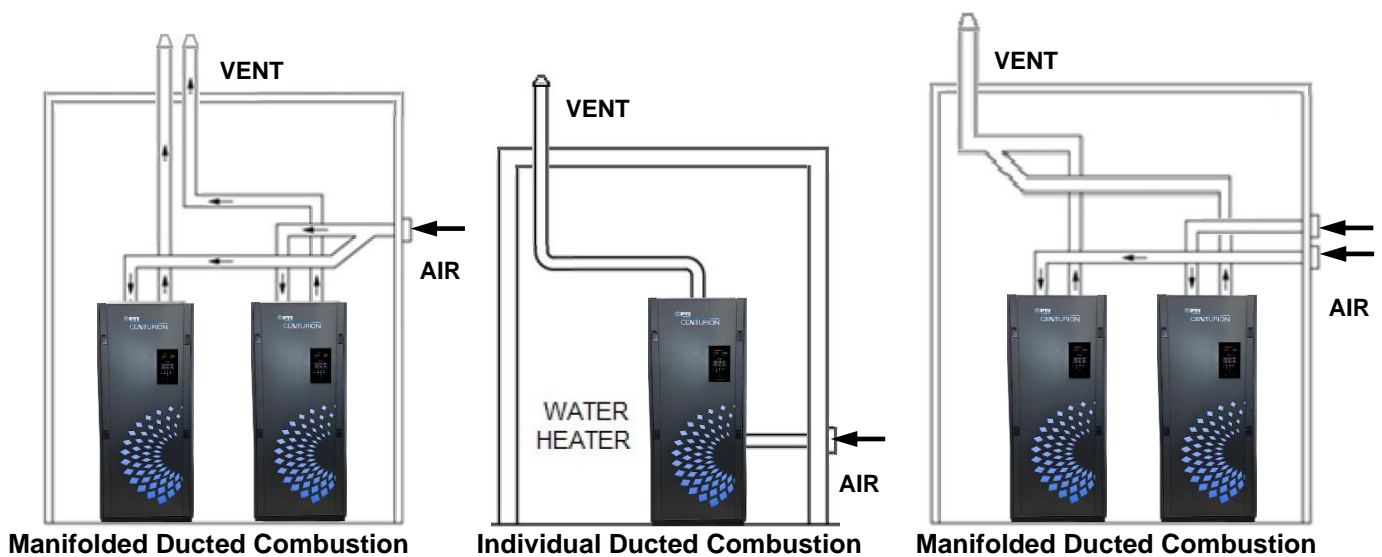
**Figure 14b: Individual Vents – Acceptable Installations**

**NOTE 1:** For high wind sites, a tee may be installed at the fresh air inlet. The leg of the tee connects to the combustion air intake. The branches of the tee can be in the horizontal or vertical direction, as determined by the system designer and site conditions.



**NOTE:** The inboard side panels should be removed, and the zero-side clearance kit installed (PN 58079-1),

**Figure 14c: Individual Vents – ACCEPTABLE Installations**



**Figure 14d: Individual Vents – ACCEPTABLE Installations**



**IMPORTANT!**

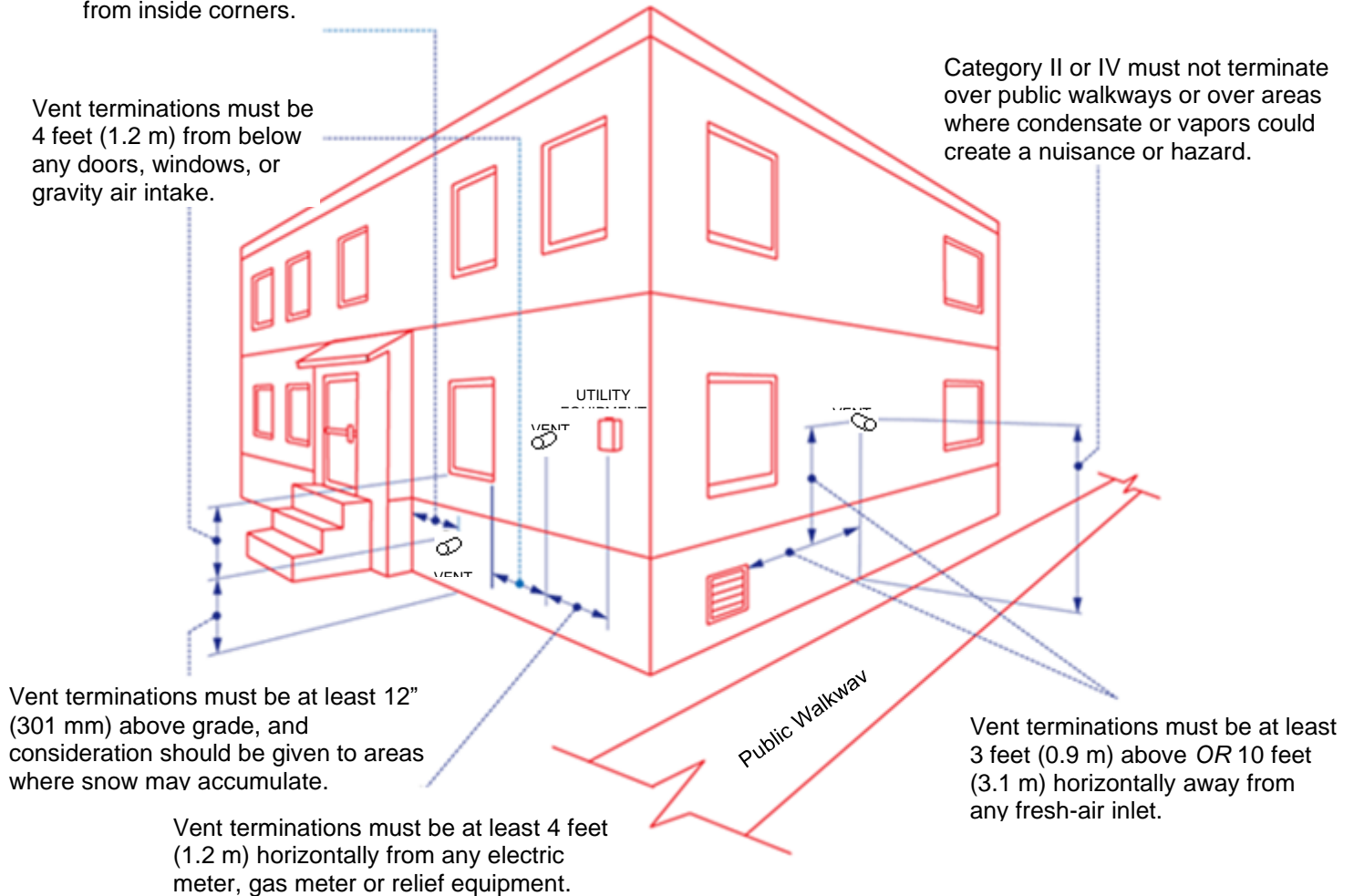
Please consult the PVI factory for all applications utilizing common ducted combustion air with common breaching of exhausts.

Other configurations, not depicted in this guide, are possible. If you intend to implement any of these options, please contact your local PVI representative or the PVI factory for project specific venting and combustion air configurations.

Vent terminations must be at least 3 feet (0.9 m) from inside corners.

Vent terminations must be 4 feet (1.2 m) from below any doors, windows, or gravity air intake.

Category II or IV must not terminate over public walkways or over areas where condensate or vapors could create a nuisance or hazard.



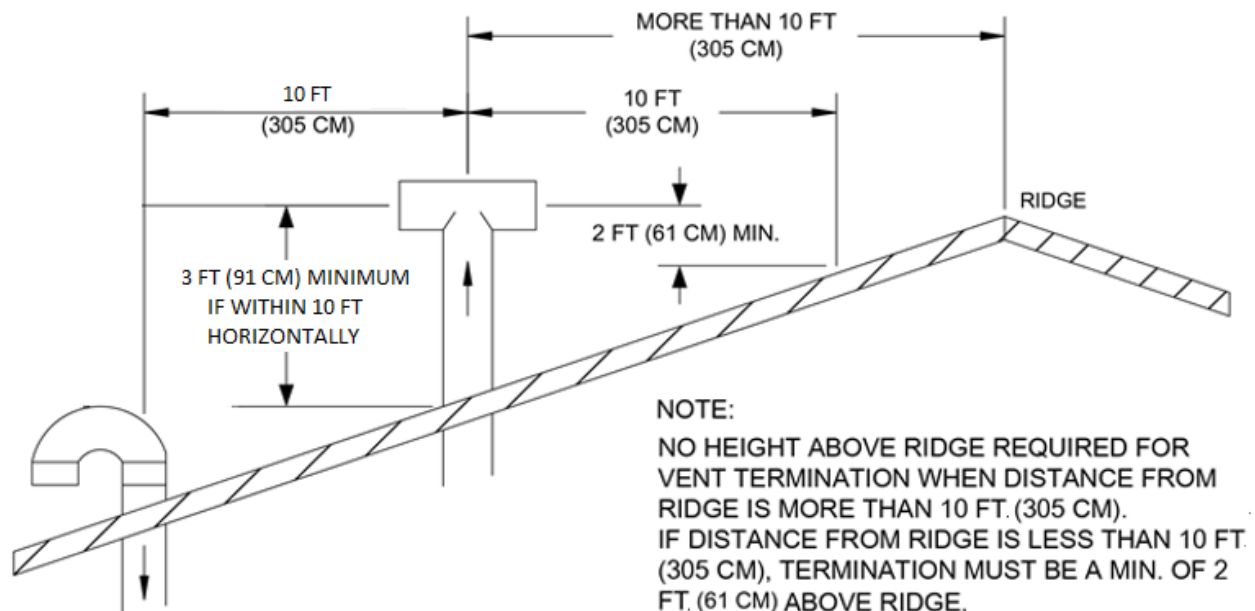
**Figure 14e: Determining Location of Vent Outlet**

**NOTE:** Vertical terminations shall extend at least 3 feet (0.9 m) above the highest point where it passes through a roof of a building and at least 2 feet (0.6 m) higher than any portion of the building within a horizontal distance of 10 feet (3.1 m). Termination that extend more than 2 feet (0.6 m) above the roof must be laterally supported

## 14.1 INSTALLATION REQUIREMENTS FOR VERTICAL VENTING

The vent termination must be located as follows (refer to Figure 14f):

- Combustion air inlet must be 3 ft. (0.9 m) below any vent outlet within 10 ft. (3.1 m).
- Vertical terminations shall extend at least 3 ft. (0.9 m) above the highest point where it passes through a roof of a building and at least 2 ft. (0.6 m) higher than any portion of the building within a horizontal distance of 10 ft. (3.1 m). Terminations that extend more than 2 ft. above the roof must be laterally supported.
- Combustion air inlet must also face away from the vent outlet.
- Use vent pipe manufacturer's vent cap or exit cone (velocity cone), fire stop, support collar, roof flushing and storm collar.
- PVI recommends the use of an exit cone in lieu of a termination rain cap for normal installations and T-termination for high-wind areas.



**Figure 14f: Acceptable Combustion Air Inlet & Vent Outlet Configuration**

**WARNING!**

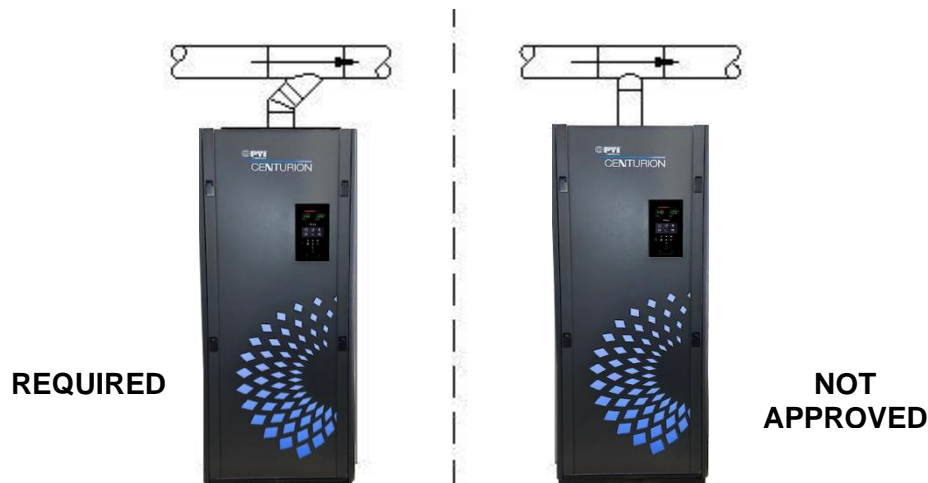
Do not insulate or otherwise wrap vent pipe or fittings. Follow the vent pipe manufacturers installation instructions for vertical venting.

## 15.COMMON VENT BREECHING (MANIFOLDED)

### IMPORTANT!

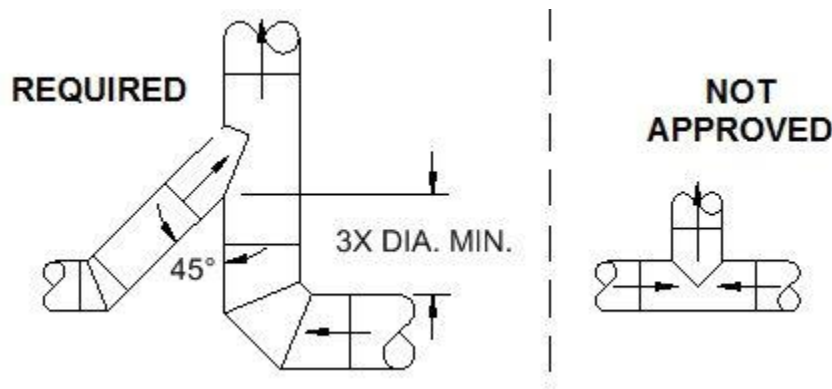
1. PVI forced draft boilers are designed for application in common vent systems.
2. Please consult the PVI factory for all applications utilizing common ducted combustion air with common breaching of exhausts.
3. PVI water heaters may share common combustion air and exhaust breaching. Other configurations, not depicted in this guide, are possible. If you intend to implement any of these options, please contact your local PVI representative or the PVI factory for project specific venting and combustion air configurations and for design assistance and approval when designing manifolded exhaust vent systems.
4. For applications requiring side wall termination of common venting, please contact your PVI representative.

Connections to common vent breeching or duct work must be accomplished with a 45° elbow, or boot-tee, in the direction of flow in the main breeching. “Tees” must not be used to accomplish these connections - see Figure 15a. The required minimum common venting vertical vent run should be 10 feet (3.1 m) up to vertical termination after the last unit is connected to common header.



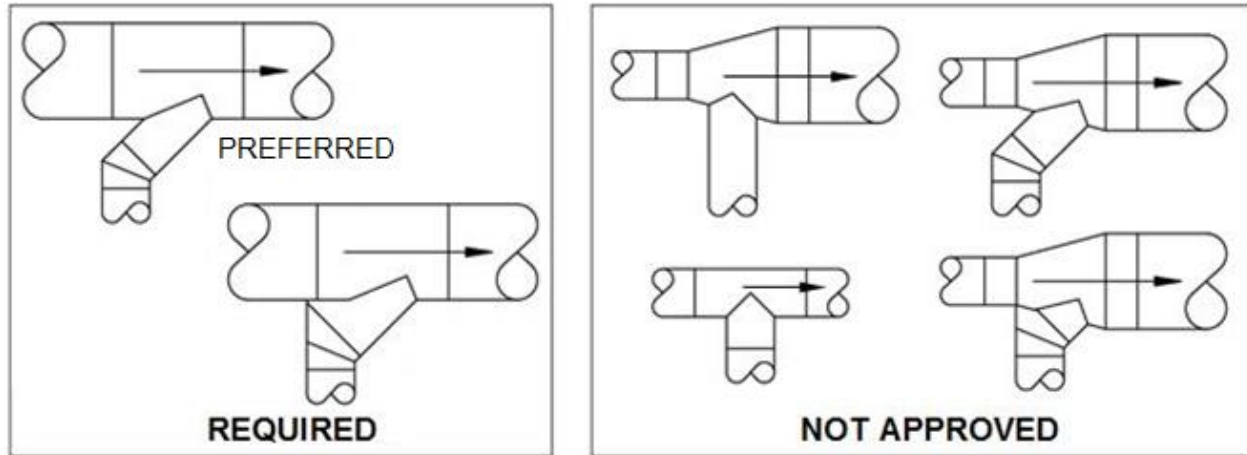
**Figure 15a: Required Connections to Common Vent Breeching**

Interconnection of groups of units must *never* be accomplished via a “tee”. As shown in Figure 15b, connect one of the branches common pipe downstream of the main branch connection via a 45° angle. The main branch diameter should be that required from termination to the farthest connected unit.



**Figure 15b: Required Interconnection of Groups of Units**

Figure 15c illustrates the preferable “transition vent section” when making the 45° connection into a main. The main can also remain at one diameter, as long as it is sized for the total number of units vented and the 45° branch connection is retained. Use of the recommended “transition” assembly will reduce the overall system pressure drop.



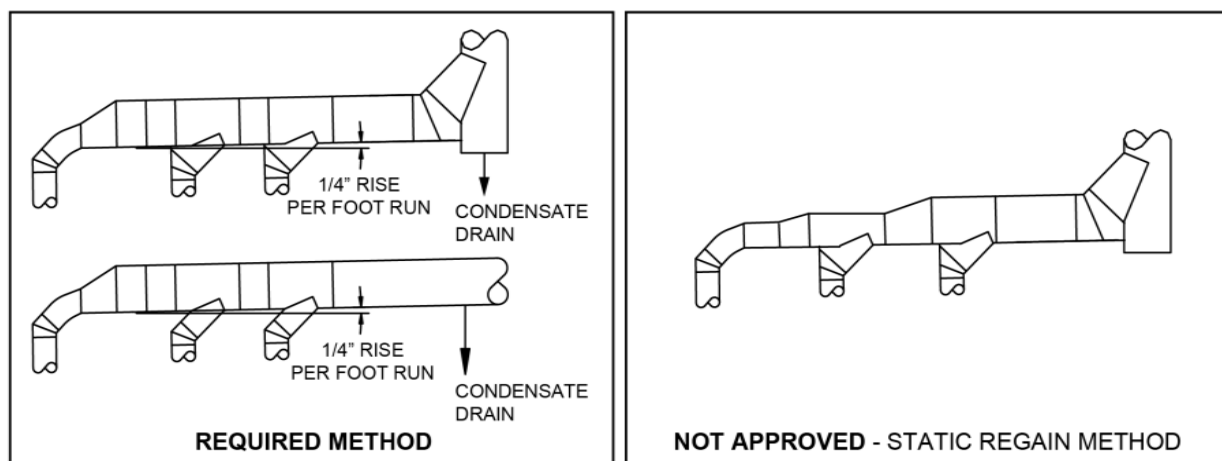
**Figure 15c: Required Transition Vent Sections**

The vent system should always be pitched up ¼-inch per foot (21 mm per m) of run towards the vent termination (see Figure 15d). This will enable condensate to drain back to the unit for disposal. Low spots in the vent must be avoided. Inspect periodically to ensure correct drainage.

As shown in Figure 15d, the unit at the end of the vent main must be connected via an elbow. An end cap must not be used as it may cause vibration and flue pressure fluctuations.

As discussed previously, the static regain method should not be used for common ductwork, but rather, the one duct size should be used for the common run.

Centurion vents must never be interconnected to those connected to another manufacturers' equipment.



**Figure 15d: Connection of Unit at End of Vent Main**

**16.PRESSURE DROP AND DRAFT DATA TABLES**

**16.1 DISCHARGE FLUE VENT PRESSURE DROP**

**Table 16-a: Discharge Venting Pressure Drop for Single CEN2000**

(Assuming 180 °F (82.2 °C) Water Temperature and 20 °F (11 °C) Rise at Sea Level)

Flue Vent Inch Dia. (cm)	Flue Velocity in Ft./sec (m/sec)	Straight Run in Eq. Ft. / Foot (m/m)	90° elbow Eq. Ft. (m)	45° elbow Eq. Ft. (m)	Exit Loss Horiz. Term. Eq. Ft. (m)	Exit Loss Rain Cap Eq. Ft. (m)
8 (20.3)	26.35 (8.03)	0.71 (0.71)	5.86 (1.79)	4.42 (1.35)	9.00 (2.74)	16.71 (5.09)
10 (25.4)	16.87 (5.14)	0.23 (0.23)	2.08 (0.63)	1.59 (0.48)	3.69 (1.12)	6.85 (2.09)
12 (30.5)	11.71 (3.57)	0.09 (0.09)	0.91 (0.28)	0.70 (0.21)	1.78 (0.54)	3.30 (1.01)
14 (35.6)	8.60 (2.62)	0.04 (0.04)	0.46 (0.14)	0.35 (0.11)	0.96 (0.29)	1.78 (0.54)
16 (40.6)	6.59 (2.01)	0.02 (0.02)	0.25 (0.08)	0.20 (0.06)	0.56 (0.17)	1.04 (0.32)
18 (45.7)	5.21 (1.59)	0.01 (0.01)	0.15 (0.05)	0.12 (0.04)	0.35 (0.11)	0.65 (0.20)

**16.2 DUCTED COMBUSTION AIR DUCT PRESSURE DROP**

**Table 16-b: Ducted Combustion Air Duct Pressure Drop in Eq. Ft. (m) for CEN2000**

Inlet Duct & No. Heaters	Duct Section Type	Outside Air Temperature in °F (°C)								
		-30 °F (-34.4)	-15 °F (-26.1)	0 °F (-17.8)	20 °F (-6.7)	40 °F (4.4)	60 °F (15.6)	80 °F (26.7)	100 °F (37.8)	120 °F (48.9)
8" Duct Single Heater	Straight Run	0.40 (0.40)	0.41 (0.41)	0.42 (0.42)	0.43 (0.43)	0.44 (0.44)	0.46 (0.46)	0.47 (0.47)	0.49 (0.49)	0.50 (0.50)
	90° Elbow	2.13 (0.649)	2.24 (0.683)	2.35 (0.716)	2.51 (0.765)	2.67 (0.814)	2.85 (0.869)	3.04 (0.927)	3.25 (0.991)	3.47 (1.058)
	45° Elbow	1.61 (0.491)	1.69 (0.515)	1.77 (0.539)	1.89 (0.576)	2.02 (0.616)	2.15 (0.655)	2.29 (0.698)	2.45 (0.747)	2.61 (0.796)
	Ent. Loss	4.12 (1.256)	4.32 (1.317)	4.54 (1.384)	4.84 (1.475)	5.16 (1.573)	5.51 (1.679)	5.88 (1.792)	6.27 (1.911)	6.69 (2.039)
10" Duct Single Heater	Straight Run	0.13 (0.13)	0.13 (0.13)	0.14 (0.14)	0.14 (0.14)	0.15 (0.15)	0.15 (0.15)	0.16 (0.16)	0.16 (0.16)	0.17 (0.17)
	90° Elbow	0.76 (0.232)	0.80 (0.244)	0.84 (0.256)	0.89 (0.271)	0.95 (0.29)	1.01 (0.308)	1.08 (0.329)	1.15 (0.351)	1.23 (0.375)
	45° Elbow	0.58 (0.177)	0.61 (0.186)	0.64 (0.195)	0.68 (0.207)	0.73 (0.223)	0.78 (0.238)	0.83 (0.253)	0.88 (0.268)	0.94 (0.287)
	Ent. Loss	1.69 (0.515)	1.77 (0.539)	1.86 (0.567)	1.98 (0.604)	2.11 (0.643)	2.26 (0.689)	2.41 (0.735)	2.57 (0.783)	2.74 (0.835)
12" Duct Two Heaters	Straight Run	0.16 (0.16)	0.17 (0.17)	0.18 (0.18)	0.19 (0.19)	0.21 (0.21)	0.22 (0.22)	0.23 (0.23)	0.25 (0.25)	0.26 (0.26)
	90° Elbow	1.32 (0.402)	1.39 (0.424)	1.46 (0.445)	1.56 (0.475)	1.66 (0.506)	1.77 (0.539)	1.89 (0.576)	2.02 (0.616)	2.15 (0.655)
	45° Elbow	1.02 (0.311)	1.08 (0.329)	1.13 (0.344)	1.20 (0.366)	1.28 (0.39)	1.37 (0.418)	1.46 (0.445)	1.56 (0.475)	1.66 (0.506)
	Ent. Loss	3.26 (0.994)	3.42 (1.042)	3.58 (1.091)	3.82 (1.164)	4.08 (1.244)	4.35 (1.326)	4.64 (1.414)	4.95 (1.509)	5.29 (1.612)

14" Duct  Two Heaters	Straight Run	0.08 (0.08)	0.08 (0.08)	0.08 (0.08)	0.09 (0.09)	0.10 (0.10)	0.10 (0.10)	0.11 (0.11)	0.12 (0.12)	0.12 (0.12)
	90° Elbow	0.66 (0.201)	0.70 (0.213)	0.73 (0.223)	0.78 (0.238)	0.83 (0.253)	0.89 (0.271)	0.95 (0.29)	1.01 (0.308)	1.08 (0.329)
	45° Elbow	0.52 (0.158)	0.54 (0.165)	0.57 (0.174)	0.61 (0.186)	0.65 (0.198)	0.69 (0.21)	0.74 (0.226)	0.79 (0.241)	0.84 (0.256)
	Ent. Loss	1.76 (0.536)	1.84 (0.561)	1.93 (0.588)	2.06 (0.628)	2.2 (0.671)	2.35 (0.716)	2.51 (0.765)	2.67 (0.814)	2.85 (0.869)
16" Duct  Three Heaters	Straight Run	0.08 (0.08)	0.09 (0.09)	0.09 (0.09)	0.10 (0.10)	0.10 (0.10)	0.11 (0.11)	0.12 (0.12)	0.13 (0.13)	0.13 (0.13)
	90° Elbow	0.82 (0.25)	0.86 (0.262)	0.91 (0.277)	0.97 (0.296)	1.03 (0.314)	1.10 (0.335)	1.18 (0.36)	1.25 (0.381)	1.34 (0.408)
	45° Elbow	0.64 (0.195)	0.67 (0.204)	0.71 (0.216)	0.76 (0.232)	0.81 (0.247)	0.86 (0.262)	0.92 (0.28)	0.98 (0.299)	1.04 (0.317)
	Ent. Loss	2.32 (0.707)	2.43 (0.741)	2.55 (0.777)	2.72 (0.829)	2.90 (0.884)	3.10 (0.945)	3.31 (1.009)	3.53 (1.076)	3.76 (1.146)

**Table 16-b: Ducted Combustion Air Duct Pressure Drop in Eq. Ft. (m) for CEN2000 – Continued**

Inlet Duct & No. Boilers	Duct Section Type	Outside Air Temperature in °F (°C)								
		-30 °F (-34.4)	-15 °F (-26.1)	0 °F (-17.8)	20 °F (-6.7)	40 °F (4.4)	60 °F (15.6)	80 °F (26.7)	100 °F (37.8)	120 °F (48.9)
18" Duct Three Heaters	Straight Run	0.05 (0.05)	0.05 (0.05)	0.05 (0.05)	0.05 (0.05)	0.06 (0.06)	0.06 (0.06)	0.07 (0.07)	0.07 (0.07)	0.08 (0.08)
	90° Elbow	0.49 (0.149)	0.51 (0.155)	0.54 (0.165)	0.57 (0.174)	0.61 (0.186)	0.65 (0.198)	0.7 (0.213)	0.74 (0.226)	0.79 (0.241)
	45° Elbow	0.38 (0.116)	0.4 (0.122)	0.42 (0.128)	0.45 (0.137)	0.48 (0.146)	0.51 (0.155)	0.54 (0.165)	0.58 (0.177)	0.62 (0.189)
	Ent. Loss	1.45 (0.442)	1.52 (0.463)	1.59 (0.485)	1.70 (0.518)	1.81 (0.552)	1.93 (0.588)	2.06 (0.628)	2.20 (0.671)	2.35 (0.716)
18" Duct Four Heaters	Straight Run	0.08 (0.08)	0.08 (0.08)	0.09 (0.09)	0.09 (0.09)	0.10 (0.10)	0.11 (0.11)	0.11 (0.11)	0.12 (0.12)	0.13 (0.13)
	90° Elbow	0.87 (0.265)	0.91 (0.277)	0.96 (0.293)	1.02 (0.311)	1.09 (0.332)	1.16 (0.354)	1.24 (0.378)	1.32 (0.402)	1.41 (0.43)
	45° Elbow	0.68 (0.207)	0.71 (0.216)	0.75 (0.229)	0.80 (0.244)	0.85 (0.259)	0.91 (0.277)	0.97 (0.296)	1.03 (0.314)	1.10 (0.335)
	Ent. Loss	2.57 (0.783)	2.70 (0.823)	2.83 (0.863)	3.02 (0.92)	3.22 (0.981)	3.44 (1.049)	3.67 (1.119)	3.91 (1.192)	4.18 (1.274)
20" Duct Four Heaters	Straight Run	0.05 (0.05)	0.05 (0.05)	0.05 (0.05)	0.06 (0.06)	0.06 (0.06)	0.06 (0.06)	0.07 (0.07)	0.07 (0.07)	0.08 (0.08)
	90° Elbow	0.55 (0.168)	0.57 (0.174)	0.60 (0.183)	0.64 (0.195)	0.68 (0.207)	0.73 (0.223)	0.78 (0.238)	0.83 (0.253)	0.88 (0.268)
	45° Elbow	0.43 (0.131)	0.45 (0.137)	0.47 (0.143)	0.5 (0.152)	0.53 (0.162)	0.57 (0.174)	0.61 (0.186)	0.65 (0.198)	0.69 (0.21)
	Ent. Loss	1.69 (0.515)	1.77 (0.539)	1.86 (0.567)	1.98 (0.604)	2.11 (0.643)	2.26 (0.689)	2.41 (0.735)	2.57 (0.783)	2.74 (0.835)

- NOTES:** 1) Calculation assumes 500 SCFM (14.16 m<sup>3</sup>/min) per unit at full fire rate  
 2) Units for "Straight Run" pressure drop values are equivalent feet per foot (eq. m / m)  
 3) Units for "Elbows" and "Ent. Loss" are equivalent feet per item (eq. m / item)



**16.3 GROSS NATURAL DRAFT**

**Table 16-c Part 1: Gross Natural Draft for CEN2000 Water Heaters— in Inch W.C.**

Stack Height in Feet	Outside Air Temperature – Fahrenheit								
	-30°F	-15°F	0°F	20°F	40°F	60°F	80°F	100°F	120°F
5	0.024	0.022	0.021	0.018	0.016	0.014	0.011	0.009	0.007
10	0.048	0.045	0.041	0.037	0.032	0.028	0.023	0.018	0.014
15	0.072	0.067	0.062	0.055	0.048	0.041	0.034	0.028	0.021
20	0.096	0.089	0.083	0.073	0.064	0.055	0.046	0.037	0.028
25	0.120	0.112	0.103	0.092	0.080	0.069	0.057	0.046	0.034
30	0.144	0.134	0.124	0.110	0.096	0.083	0.069	0.055	0.041
35	0.168	0.156	0.144	0.128	0.112	0.096	0.080	0.064	0.048
40	0.193	0.179	0.165	0.147	0.128	0.110	0.092	0.073	0.055
45	0.217	0.201	0.186	0.165	0.144	0.124	0.103	0.083	0.062
50	0.241	0.223	0.206	0.183	0.160	0.138	0.115	0.092	0.069
75	0.361	0.335	0.309	0.275	0.241	0.206	0.172	0.138	0.103
100	0.481	0.447	0.413	0.367	0.321	0.275	0.229	0.183	0.138
125	0.602	0.559	0.516	0.458	0.401	0.344	0.287	0.229	0.172
150	0.722	0.670	0.619	0.550	0.481	0.413	0.344	0.275	0.206
175	0.842	0.782	0.722	0.642	0.562	0.481	0.401	0.321	0.241
200	0.963	0.894	0.825	0.734	0.642	0.550	0.458	0.367	0.275

**Table 16-c Part 1: Gross Natural Draft for BMK1500, BMK2000, BMK2500, BMK3000 Low NOx Boilers – in Pascals**

Stack Height in Meters	Outside Air Temperature – Celsius								
	-34.4 °C	-26.1 °C	-17.8 °C	-6.7 °C	4.4 °C	15.6 °C	26.7 °C	37.8 °C	48.9 °C
1.52	6.0	5.5	5.2	4.5	4.0	3.5	2.7	2.2	1.7
3.05	12.0	11.2	10.2	9.2	8.0	7.0	5.7	4.5	3.5
4.57	17.9	16.7	15.4	13.7	12.0	10.2	8.5	7.0	5.2
6.10	23.9	22.2	20.7	18.2	15.9	13.7	11.5	9.2	7.0
7.62	29.9	27.9	25.7	22.9	19.9	17.2	14.2	11.5	8.5
9.14	35.9	33.4	30.9	27.4	23.9	20.7	17.2	13.7	10.2
10.67	41.8	38.9	35.9	31.9	27.9	23.9	19.9	15.9	12.0
12.19	48.1	44.6	41.1	36.6	31.9	27.4	22.9	18.2	13.7
13.72	54.1	50.1	46.3	41.1	35.9	30.9	25.7	20.7	15.4
15.24	60.0	55.5	51.3	45.6	39.9	34.4	28.6	22.9	17.2
22.86	89.9	83.4	77.0	68.5	60.0	51.3	42.8	34.4	25.7
30.48	119.8	111.3	102.9	91.4	80.0	68.5	57.0	45.6	34.4
38.10	150.0	139.2	128.5	114.1	99.9	85.7	71.5	57.0	42.8
45.72	179.8	166.9	154.2	137.0	119.8	102.9	85.7	68.5	51.3
53.34	209.7	194.8	179.8	159.9	140.0	119.8	99.9	80.0	60.0
60.96	239.9	222.7	205.5	182.8	159.9	137.0	114.1	91.4	68.5

**Table 16-c Part 2: Gross Natural Draft for CEN2000 Water Heaters – In Eq. Ft.**

Stack Height in Feet	Outside Air Temperature (°F)								
	-30°F	-15°F	0°F	20°F	40°F	60°F	80°F	100°F	120°F
5	4.1	3.8	3.5	3.2	2.8	2.4	2.0	1.6	1.2
10	8.3	7.7	7.1	6.3	5.5	4.7	3.9	3.2	2.4
15	12.4	11.5	10.6	9.5	8.3	7.1	5.9	4.7	3.5
20	16.6	15.4	14.2	12.6	11.0	9.5	7.9	6.3	4.7
25	20.7	19.2	17.7	15.8	13.8	11.8	9.9	7.9	5.9
30	24.8	23.1	21.3	18.9	16.6	14.2	11.8	9.5	7.1
35	29.0	26.9	24.8	22.1	19.3	16.6	13.8	11.0	8.3
40	33.1	30.8	28.4	25.2	22.1	18.9	15.8	12.6	9.5
45	37.3	34.6	31.9	28.4	24.8	21.3	17.7	14.2	10.6
50	41.4	38.4	35.5	31.5	27.6	23.7	19.7	15.8	11.8
75	62.1	57.7	53.2	47.3	41.4	35.5	29.6	23.7	17.7
100	82.8	76.9	71.0	63.1	55.2	47.3	39.4	31.5	23.7
125	103.5	96.1	88.7	78.9	69.0	59.1	49.3	39.4	29.6
150	124.2	115.3	106.4	94.6	82.8	71.0	59.1	47.3	35.5
175	144.9	134.5	124.2	110.4	96.6	82.8	69.0	55.2	41.4
200	165.6	153.8	141.9	126.2	110.4	94.6	78.9	63.1	47.3

**Note:** Based on 160 °F to 180 °F

**Table 16-c Part 2: Gross Natural Draft for CEN2000 Water Heaters – in Eq. Meters**

Stack Height in Meters	Outside Air Temperature – Celsius								
	-34.4 °C	-26.1 °C	-17.8 °C	-6.7 °C	4.4 °C	15.6 °C	26.7 °C	37.8 °C	48.9 °C
1.52	1.2	1.2	1.1	1.0	0.9	0.7	0.6	0.5	0.4
3.05	2.5	2.3	2.2	1.9	1.7	1.4	1.2	1.0	0.7
4.57	3.8	3.5	3.2	2.9	2.5	2.2	1.8	1.4	1.1
6.10	5.1	4.7	4.3	3.8	3.4	2.9	2.4	1.9	1.4
7.62	6.3	5.9	5.4	4.8	4.2	3.6	3.0	2.4	1.8
9.14	7.6	7.0	6.5	5.8	5.1	4.3	3.6	2.9	2.2
10.67	8.8	8.2	7.6	6.7	5.9	5.1	4.2	3.4	2.5
12.19	10.1	9.4	8.7	7.7	6.7	5.8	4.8	3.8	2.9
13.72	11.4	10.5	9.7	8.7	7.6	6.5	5.4	4.3	3.2
15.24	12.6	11.7	10.8	9.6	8.4	7.2	6.0	4.8	3.6
22.86	18.9	17.6	16.2	14.4	12.6	10.8	9.0	7.2	5.4
30.48	25.2	23.4	21.6	19.2	16.8	14.4	12.0	9.6	7.2
38.10	31.5	29.3	27.0	24.0	21.0	18.0	15.0	12.0	9.0
45.72	37.9	35.1	32.4	28.8	25.2	21.6	18.0	14.4	10.8
53.34	44.2	41.0	37.9	33.6	29.4	25.2	21.0	16.8	12.6
60.96	50.5	46.9	43.3	38.5	33.6	28.8	24.0	19.2	14.4

**Note:** Based on 71 °C to 82 °C water temp.

**16.4 ALTITUDE CORRECTION**

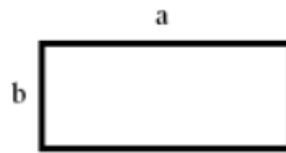
**Table 16-d: Altitude Correction**

Site Elevation Above Sea Level		Altitude Correction Factor (CF)
Feet	Meters	
0	0	1
500	152.4	0.982
1000	304.8	0.964
1500	457.2	0.947
2000	609.6	0.930
2500	762.0	0.913
3000	914.4	0.896
3500	1066.8	0.880
4000	1219.2	0.864
4500	1371.6	0.848
5000	1524.0	0.832
5500	1676.4	0.817
6000	1828.8	0.801
6500	1981.2	0.787
7000	2133.6	0.772
7500	2286.0	0.758
8000	2438.4	0.743
8500	2590.8	0.729
9000	2743.2	0.715
9500	2895.6	0.701
10000	3048.0	0.688

**16.5 ROUND VS SQUARE DUCT**

**Table 5: Round Duct of Identical Pressure Drop to Rectangular Duct**

**Formula:**  $d_e = 1.3 (a \times b)^{0.625} / (a + b)^{0.25}$



**In Inches**

Adjacent Side of Duct in inches	Side of Rectangular Duct in Inches									
	6	8	10	12	14	16	18	20	22	24
6	6.6									
8	7.6	8.7								
10	8.4	9.8	10.9							
12	9.1	10.7	12	13.1						
14	9.8	11.5	12.9	14.2	15.3					
16	10.4	12.2	13.7	15.1	16.4	17.5				
18	11	12.9	14.5	16	17.3	18.5	19.7			
20	11.5	13.5	15.2	16.8	18.2	19.5	20.7	21.9		
22	12	14.1	15.9	17.6	19.1	20.4	21.7	22.9	24	
24	12.4	14.6	16.5	18.3	19.9	21.3	22.7	23.9	25.1	26.2

**In Centimeters**

Adjacent Side of Duct in cm	Side of Rectangular Duct in Centimeters									
	15.24	20.32	25.4	30.48	35.56	40.64	45.72	50.8	55.88	60.96
15.24	16.76									
20.32	19.30	22.10								
25.4	21.34	24.89	27.69							
30.48	23.11	27.18	30.48	33.27						
35.56	24.89	29.21	32.77	36.07	38.86					
40.64	26.42	30.99	34.80	38.35	41.66	44.45				
45.72	27.94	32.77	36.83	40.64	43.94	46.99	50.04			
50.8	29.21	34.29	38.61	42.67	46.23	49.53	52.58	55.63		
55.88	30.48	35.81	40.39	44.70	48.51	51.82	55.12	58.17	60.96	
60.96	31.50	37.08	41.91	46.48	50.55	54.10	57.66	60.71	63.75	66.55

**Reference:**

1. *National Fuel Gas Code, 2006 edition*, American National Standards Institute, Inc (ANSI Z223.1-2006) and *National Fire Protection Association* (NFPA54-2006)
2. CSA B149.1 (For Canada installations)



© PVI Industries, LLC, 2024