

TURBOPOWER® GAS • PACKAGED WATER HEATER

AquaPLEX® STORAGE TANK (UNLINED DUPLEX ALLOY)

TANK SERIES 750 GALLONS

Model Number ③	Recovery gph ①		Input Btu/h	* Min. Inlet Flow Gas Pressure "W.C.	Dimensions (inches)					Blower Motor		Shipping Weight lbs
	40°- 120°F	40°- 140°F			A	B	C	J ∅	K	HP	Volt/Ph/ Amps	
250 L 750A-TPL	250	200	199,000	4.5	21	4	3/4	10-1/4	45-3/4	1/6	115/1∅/13	2180
375 L 750A-TPL	375	300	300,000	4.5	21	4	3/4	10-1/4	45-3/4	1/6	115/1∅/13	2190
500 L 750A-TPL	500	400	399,000	4.5	21	5	3/4	10-1/4	45-3/4	1/6	115/1∅/13	2200
750 L 750A-TP	750	600	600,000	6.0	28-3/4	6	1	16	45-3/4	1/3	115/1∅/18	2280
1000 L 750A-TP	1000	800	800,000	6.0	28-3/4	8	1-1/4	16	45-3/4	1/3	115/1∅/18	2320
1250 L 750A-TP	1250	1000	1,000,000	6.0	28-3/4	8	2	16	45-3/4	1/2	115/1∅/10	2590
1500 L 750A-TP	1500	1200	1,200,000	6.5	28-3/4	8	2	16	45-3/4	1/2	115/1∅/10	2770
2000 L 750A-TP	2000	1600	1,600,000	9.0	48-3/4	10	2	27	45-3/4	1-1/2	115/1∅/20	3035
2500 L 750A-TP	2500	2000	2,010,000	10.5	48-3/4	10	2-1/2	27	45-3/4	1-1/2	115/1∅/20	3055

- ① Recoveries based on 83% thermal efficiency. ASHRAE 90.1 compliant for efficiency and standby loss.
- ② "J" dimension is for the burner housing only. Gas train may exceed this dimension.
- ③ Models with "TPL" suffix are less than 55 ppm NOx. SCAQMD models 2TPL (200MBH), 3TPL (300MBH) and 4TPL (400MBH).
- * The information presented is for Natural gas 0.6 S.G.— For operation with propane (LP gas), consult factory. Dimensions are in inches unless otherwise specified. For standard and optional equipment, see form PV 8050.

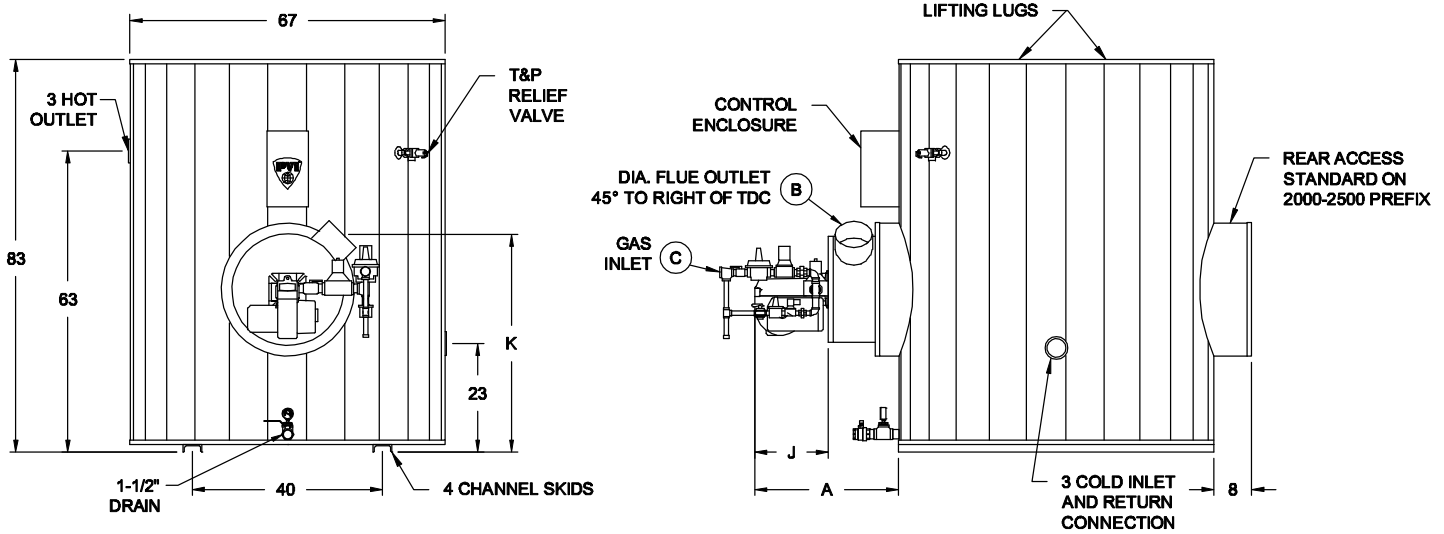

*** GAS PRESSURE REQUIREMENTS**

SEE TABLE ABOVE FOR **MINIMUM** PRESSURE BY MODEL NUMBER.
MAXIMUM STATIC INLET PRESSURE:
 10.5" W.C. for 199,000 - 399,000 AND 14" W.C. for > 399,000.

VENTING REQUIREMENTS

-0.02" TO -0.06" W.C. (NEGATIVE PRESSURE)
 CATEGORY I, TYPE B VENTING
*ENTIRE VENT SYSTEM SHOULD NEVER BE SIZED BASED UPON THE VENT CONNECTION DIAMETER EXCLUSIVELY.
 FOR PROPER SIZING, CONSULT THE NATIONAL FUEL GAS CODE UNDER "FAN-ASSISTED."*

STANDARD ELECTRICAL REQUIREMENTS

CONTROL VOLTAGE: 120V, 1∅, 60 HZ., 2 AMPS.
 MOTOR VOLTAGE:
 208V, 230V, AND 460V MOTORS ARE AVAILABLE BUT WILL REQUIRE A SEPARATE 120V/2 amps CONTROL CIRCUIT OR AN OPTIONAL CONTROL CIRCUIT TRANSFORMER.

PVI RESERVES THE RIGHT TO CHANGE THE DESIGN AND SPECIFICATION WITHOUT NOTICE.