



# TURBOPOWER® GAS • PACKAGED WATER HEATER AQUAPLEX® STORAGE TANK (UNLINED DUPLEX ALLOY)

## TANK SERIES 150 GALLONS

Model Number ③	Recovery gph ①		Input Btu/h	* Min. Inlet Flow Gas Pressure "W.C.	Dimensions (inches)				Blower Motor		Shipping Weight lbs EST
	40°- 120°F	40°- 140°F			A	B	C	J ④	HP	Volt/Ph/ Amps	
250 L 150A-TPL	250	200	199,000	4.5	21	4	3/4	10-1/4	1/6	115/1Ø/3	1035
375 L 150A-TPL	375	300	300,000	4.5	21	4	3/4	10-1/4	1/6	115/1Ø/3	1080
500 L 150A-TPL	500	400	399,000	4.5	21	5	3/4	10-1/4	1/6	115/1Ø/3	1105
750 L 150A-TP	750	600	600,000	6.0	40	6	1	16	1/3	115/1Ø/8	1155
1000 L 150A-TP	1000	800	800,000	6.0	40	8	1-1/4	16	1/3	115/1Ø/8	1365

- ① Recoveries based on 83% thermal efficiency. ASHRAE 90.1 compliant for efficiency and standby loss.
- ② "J" dimension is for the burner housing only. Gas train may exceed this dimension.
- ③ Models with "TPL" suffix are less than 55 ppm NOx. SCAQMD models 2TPL (200MBH), 3TPL (300MBH) and 4TPL (400MBH).
- ④ 4" x 37 1/2" Channel skids for inputs ≤ 400 MBtu/h.  
4" x 54 1/2" Channel skids for inputs ≥ 600 MBtu/h.
- \* The information presented is for Natural gas 0.6 S.G.— For operation with propane (LP gas), consult factory. Dimensions are in inches unless otherwise specified. For standard and optional equipment, see form PV 8050.

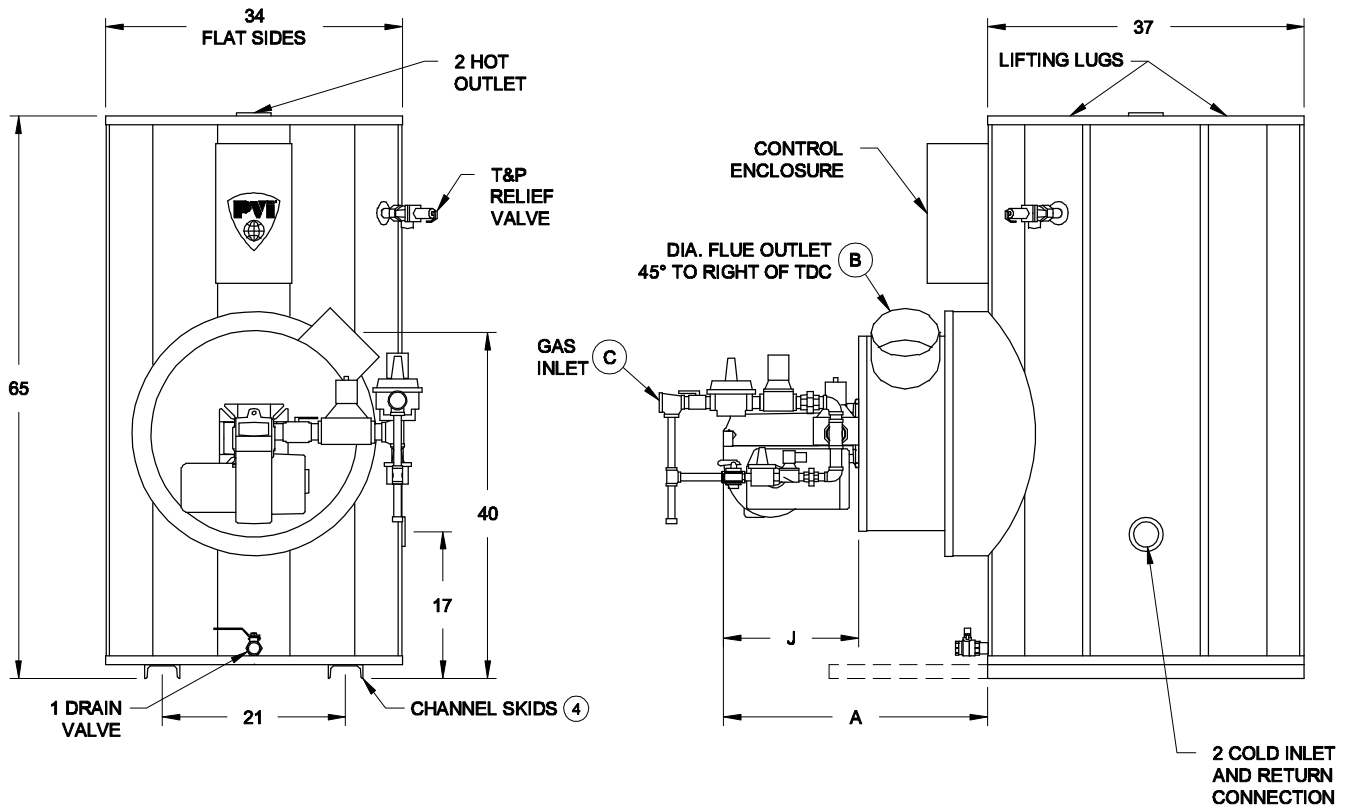

* GAS PRESSURE REQUIREMENTS
SEE TABLE FOR <u>MINIMUM</u> PRESSURE BY MODEL NUMBER. MAXIMUM STATIC INLET PRESSURE: 10.5" W.C. for 199,000 - 399,000 AND 14" W.C. for > 399,000.
VENTING REQUIREMENTS
-0.02" TO -.06" W.C. (NEGATIVE PRESSURE) TYPE B VENTING ENTIRE VENT SYSTEM SHOULD NEVER BE SIZED BASED UPON THE VENT CONNECTION DIAMETER EXCLUSIVELY. FOR PROPER SIZING, CONSULT THE NATIONAL FUEL GAS CODE UNDER "FAN-ASSISTED."

STANDARD ELECTRICAL REQUIREMENTS
CONTROL VOLTAGE: 120V, 1Ø, 60 HZ., 2 AMPS. MOTOR VOLTAGE: 208V, 230V, AND 460V MOTORS ARE AVAILABLE BUT WILL REQUIRE A SEPARATE 120V/2 amps CONTROL CIRCUIT OR AN OPTIONAL CONTROL CIRCUIT TRANSFORMER.

PVI RESERVES THE RIGHT TO CHANGE THE DESIGN AND SPECIFICATION WITHOUT NOTICE.