

INSTALLATION & MAINTENANCE MANUAL FOR

PVI FIREPOWER®

BG400 GAS BURNER

140,000 thru 1,400,000 Btu/h

CARBON MONOXIDE WARNING:

CAUTION: IMPROPER COMBUSTION MAY CAUSE SERIOUS INJURY.

PVI recommends a seasonal or annual combustion check-out be performed by a qualified service agency to ensure safe and efficient operation.

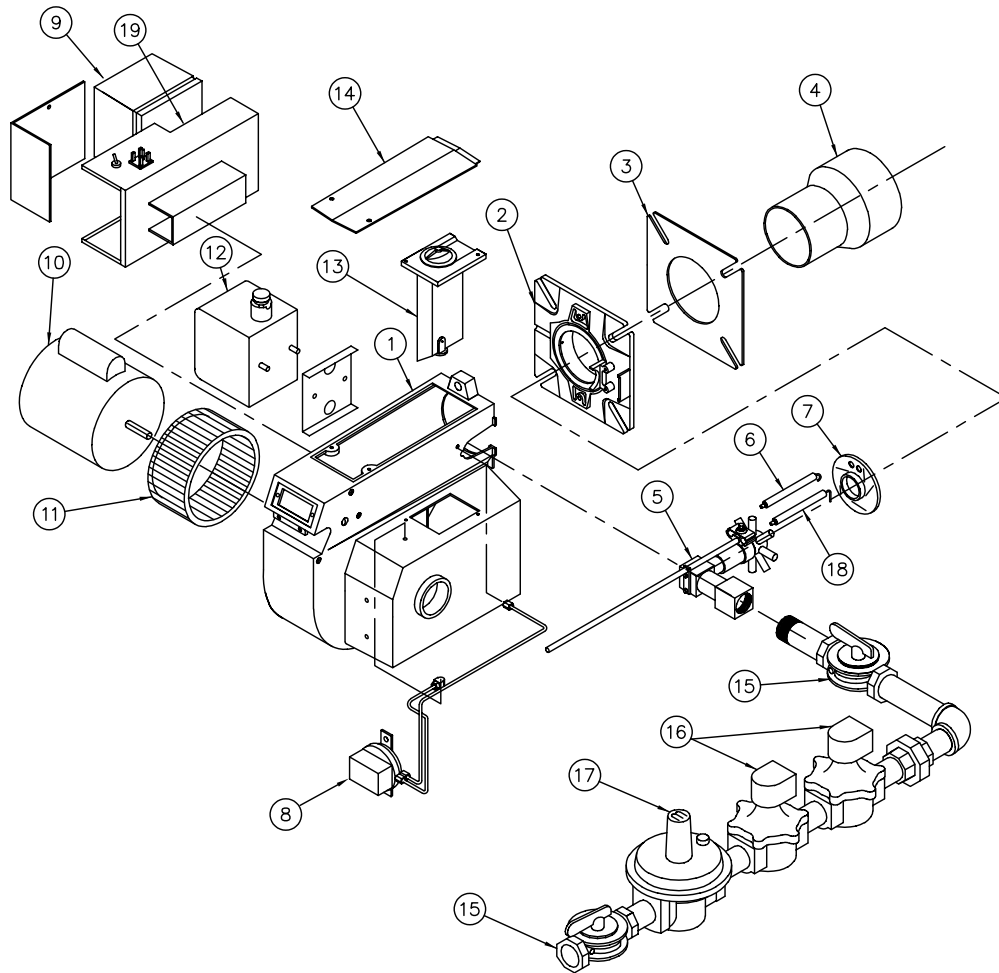

**Typical Construction
Figure 21A-1**

- | | |
|------------------------|--------------------------|
| 1. Burner housing | 11. Fan wheel |
| 2. Mounting flange | 12. Ignition transformer |
| 3. Flange gasket | 13. Damper assembly |
| 4. Blast tube | 14. Housing cover |
| 5. Gas nozzle assembly | 15. Manual gas valve |
| 6. Ignition electrodes | 16. Electric gas valve |
| 7. Pressure plate | 17. Gas regulator |
| 8. Air switch | 18. Flame rod |
| 9. Flame safeguard | 19. Control enclosure |
| 10. Fan motor | |

PVI FIREPOWER®

BG400 GAS BURNER

FOR YOUR SAFETY WHAT TO DO WHEN YOU SMELL GAS:

- DO NOT try to light any appliance
- DO NOT touch any electrical switch; DO NOT use any phone in your building.
- IMMEDIATELY call your gas supplier from a phone outside the building. Follow the gas supplier's instructions.
- If you cannot reach your gas supplier, CALL THE FIRE DEPARTMENT.

FOR YOUR SAFETY

DO NOT store or use gasoline or other flammable vapors and liquids in the vicinity of this or any other appliance.

FOR YOUR SAFETY

WARNING: Improper installation, adjustment, alteration, service or maintenance can cause injury or property damage. Refer to this manual for assistance, or consult a qualified installer

CAUTION: CONDUCT THE FOLLOWING GAS TRAIN LEAKAGE TEST BEFORE START-UP, AT ANNUAL INTERVALS AND PRIOR TO INVESTIGATING THE CAUSE OF ANY REPORTED OCCURRENCES OF DELAYED IGNITION.

1. Using an appropriate bubble detection solution, thoroughly coat all gas train pipe connections. If any bubbles are detected, the leaking connection must be tightened, recoated and rechecked to assure stoppage of the leak.
2. Attach a manometer, to measure gas pressure, at the manual gas shutoff valve located just upstream of the gas train. Adjust gas train inlet pressure to the specified value (e.g. 14 in. W.C.), and tightly close the gas train manual shutoff valve closest to burner.
3. Reattach the manometer to the gas train manual shutoff valve at the burner and record the measured gas pressure in inches of water column (in W.C.). Measure gas pressure again after 15 minutes. If gas pressure has increased 0.5" W.C. or more, the gas leak must be isolated to one or more of the operating gas valves, for example, a solenoid actuated gas shutoff valve. After any leaking valve is replaced, the reassembled gas train must be leak tested again before start-up is attempted. (NOTE: All gas valves removed because of suspected leakage must be returned to PVI Customer Service for disposition.)

ELECTRICAL

1. Wiring to the unit should conform to the National Electrical Code or the code legally authorized to your locality. A fused disconnect switch should be used for water heater control. Service wiring connections of 120V, 1 phase, 60 Hz. are located in the enclosure on water heater. (Refer to wiring diagram supplied with appliance.)

NOTE: Use only copper wire of proper sizing for incoming service. Damage resulting from use of aluminum wiring will be excluded from coverage under the warranty of this unit.

PVI FIREPOWER®

BG400 GAS BURNER START-UP

(Refer to Figure 21A-1 to identify burner parts)

1. Remove the enclosure panel cover on the water heater or boiler to expose the control circuit. Located on the backside of this cover is a wiring diagram. This diagram will show the controls used in our circuitry.
2. Visually check that all components are intact and no damage has occurred during transit.
3. Check all connections within the control cabinet. A loose connection could cause intermittent shutdowns.
4. Some burners will use direct spark ignition. They may use a single gas pressure regulator and gas valve or multiple valves and regulators. On a call for heat, the motor starts, the gas primary control is energized, and after a short delay (pre-purge) the gas valve(s) opens and ignition should occur. **NOTE: Do not tamper with or readjust program dipswitch settings. This will cause the control to become inoperable. Damage resulting from tampering will be excluded from coverage under the warranty of this unit.**
5. Remove the flame safeguard control from its base. Check the connections in control mounting base; loose connections can cause nuisance shutdowns. When applicable, check the time card or programmer, for good connection. **NOTE: Always secure gas lines and tag "Out of Service" before servicing burner nozzle or electrodes.**
6. Pull the nozzle assembly to check the flame and ignition electrodes. For details, refer to Figure 21A-5, page 7.
7. With the electrodes exposed, check them for the proper settings as called for in Figure 21A-2, page 4. Check for any hairline cracks in the insulators. Should replacement of burner electrodes be required, certain procedures must be followed. In all cases, removal of the electrodes is accomplished by loosening the electrode mounting clamps. Draw the electrodes out of the nozzle assembly through holes in the pressure plate.
8. Inspect the electrodes for cracked ceramic or loose retaining studs that hold the wire within the ceramic. Select the proper pressure plate hole to place each electrode and insert the electrode through the hole, retaining stud end first.
9. Tighten the electrode mounting clamp slightly until electrode ceramics are seated firmly and completely in the mounting bracket without gaps between ceramics and mounting bracket at the bearing faces.
10. Measure and set electrodes according to Figure 21A-2, page 4. After the gaps and setting are complete, fully tighten the electrode mounting clamp. **Do not overtighten or the insulation may crack.**
11. Replace nozzle assembly; be sure to connect the flame and spark rod wires before installing nozzle assembly fully into blast tube. Check connections on the ends of the flame and spark rod wires for good contact. Look for properly stripped wire ends. Be sure connectors are firmly attached to the flame and ignition rod ends. Insulating boots can give a false feeling of proper seating. **DO NOT MOVE ELECTRODES.** Be careful not to bump electrodes. Check fan wheel for free rotation.
12. Reinstall orifices in unions (if required). Reinstall gas nozzle assembly.
13. Connect a test meter to the control for reading the flame response signal. **NOTE: Some controls read the flame signal in micro amps and some in volts DC. The MEC120 series control has two terminals marked for reading volts DC. The S89 control uses a micro amp signal for measuring flame strength. For this control, a meter must be hooked in series with the flame rod wire. Disconnect the leadwire at the S89 sensor terminal. Connect the positive lead of the meter to the quick-connect sensor terminal on the S89 and the negative lead to the free end of the sensor leadwire.**

PVI FIREPOWER®

BG400 GAS BURNER START-UP (con't)

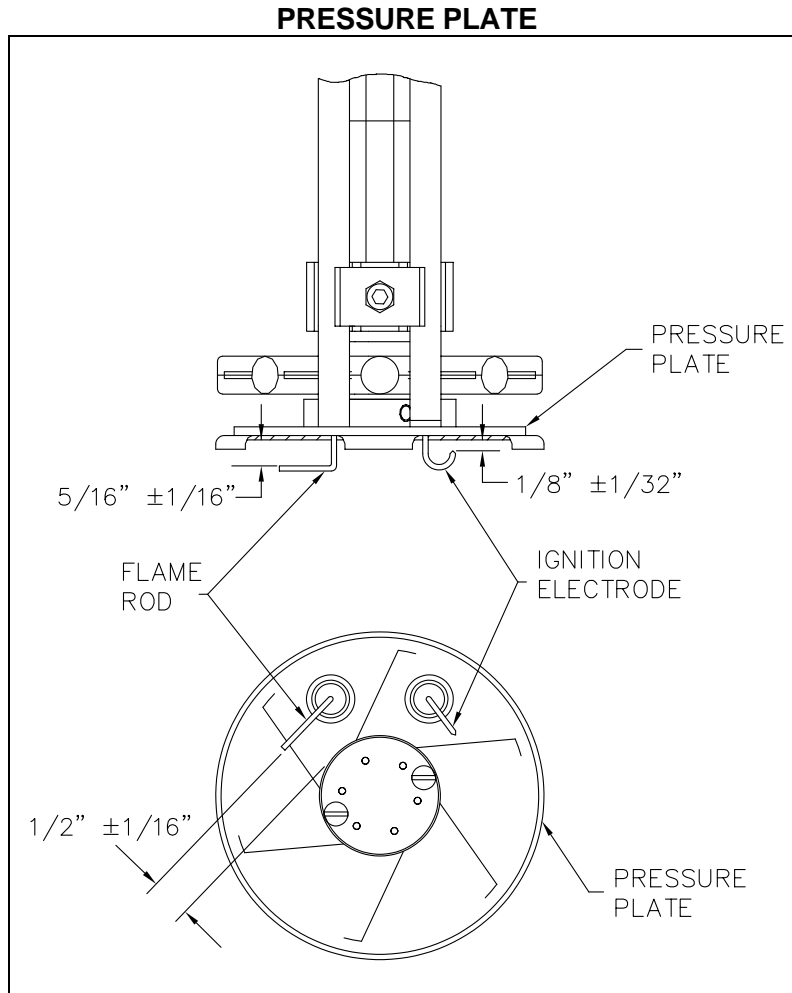

14. Be sure the tank is filled with water. Once the burner is reassembled, two devices to read pressure, preferably U-tube manometers, will be needed to read gas pressures. Connect one to read the inlet pressure of burner. This is the pressure measured before all components in the gas train. The manometer must stay connected throughout the testing, as the inlet pressure must be monitored during the firing of the burner. Record static pressure; it must not exceed 14" W.C. Pressures above this could cause damage to the diaphragm in the gas valve or pressure regulator.

15. **Burners with pilot.** (See wiring diagram.)

Connect a manometer to the manifold test port at the shutoff valve closest to the burner. Turn off the main gas shutoff valve. Set the air shutter as shown on the tag attached to gas train. This may not be the exact setting you end up with, but it is a good starting point. Turn the unit on using the rocker switch on the side of the control enclosure assembly. If the operating control switches are closed, the burner blower should come on and pre-purge begins.

If nothing happens, check the control to be sure it is not in the tripped position and reset it by pushing the flame safeguard reset button. The burner should pre-purge thirty seconds.

PVI FIREPOWER®

BG400 GAS BURNER START-UP (con't)

This section pertains to MEC120 control only.

When the blower motor starts, the air proving light on the MEC120 should be on. This indicates a positive air flow condition. If the air proving light is not on, turn air proving switch adjustment screw counter-clockwise until the air proving light comes on, then turn screw one turn counter-clockwise. If the gas valves open and close intermittently during normal operation, turn screw one half turn counter-clockwise until this condition ceases. This procedure should be followed with every burner.

After purging is complete, terminal 3 energizes the pilot valve and terminal 4 energizes the ignition transformer on the control. The pilot is then established. The VDC reading on the meter should read a steady 14-17 VDC. Each different control will have the required flame response signal stamped on it. This is the minimum for it to properly operate. If the pilot fails to light during the initial period, it is probably due to air in the line. The control will lock out. Press the flame safeguard reset button to restart burner and begin the purge cycle again.

Once the flame is established, set the pilot pressure (measured downstream of gas valve) at pressure shown on the tag attached to gas train. Next, open the main gas valve slowly. Set manifold pressure at pressure shown on the tag attached to gas train. Do not screw the adjusting nut of the regulator in past the point where no further increase in manifold pressure is noted. Check the incoming pressure with the burner running. This is recorded as inlet flow pressure.

Our standard flow pressure requirement on these burners is 8" W.C. flow. If the required manifold pressure cannot be reached, check the inlet pressure. It should be a minimum of that shown above with the burner running on full input. It is important the incoming pressure does not fall below these minimums or nuisance control lockouts could occur.

NOTE: Where low gas pressure is a problem, special arrangements may have been made to fire the burner with reduced pressure. The appliance data decal will reflect this information.

16. Direct Spark Ignition Burners-No pilot. (Refer to wiring diagram.)

Connect manometer to the manifold test port. Set manifold pressure as shown on the tag attached to gas train. This may not be the exact setting you end up with, but a good starting point. Some units are equipped with an optional vent restrictor. Adjust air flow as needed.

Turn the unit on, using the rocker switch on the side of the control enclosure assembly. The burner should come on and ignition occur. If the burner fails to ignite, there may have been air in the line. To reset the control, turn the switch off for 60 seconds (S89 controls only) and it should automatically reset, or push the reset button on the control. If after the appropriate prepurge, ignition does not occur, turn the air proving switch adjustment screw counter-clockwise until TFI (trial for ignition) occurs. Now in order to more precisely adjust the air failure set point, slowly turn screw clockwise until the burner shuts off. Then turn screw counter-clockwise one turn. If the gas valves open and close intermittently during normal operation, turn screw one half turn counter-clockwise until this condition ceases.

Once the burner fires, set manifold pressure at pressure shown on the tag attached to gas train. There will be a tap on the downstream side of the valve to measure pressure. The manifold pressure must be taken downstream of the gas valve. Check the incoming pressure with the burner running. This recorded flow pressure must be a minimum of 8" W.C.

17. Check flue gases with a flue analyzer to make final settings of the air damper or gas pressure regulator.
 - a. The readings need to be taken from a hole in the vent several inches downstream of the flue outlet connection.
 - b. Insert draft gauge into the test opening in the stack. Draft in stack should read -.02" to -.06" W.C. Adjust draft regulator, if installed.
 - c. Check the manifold gas pressure. If set to the factory specified pressure in (in.W.C.), proceed to paragraph (d). If the manifold gas pressure is too low, increase the gas pressure by adjusting the main gas regulator clockwise; decrease by turning counterclockwise.

PVI FIREPOWER®
BG400 GAS BURNER START-UP (con't)

- d. Gradually close air damper to decrease O₂ reading or open air damper to increase O₂ reading until optimum O₂ % (4-5%) is reached. Refer to Figure 21A-3, page 7 for adjustment details.
 - e. The CO should not exceed 300 ppm. A reading greater than 300 ppm indicates a lack of air or misadjusted gas nozzle assembly. Open air damper slightly and note any change in CO. If no improvement is seen or burner pulsates, it may be necessary to adjust the gas nozzle assembly. Refer to Figure 21A-4, page 7 for details.
 - f. Once combustion is set, take note of the gross stack temperature; maximum gross stack temperature should not exceed 330°F plus room temperature (gross temp ≤ room temp + 330). Minimum gross stack temperature should not be below 300°F plus room temperature. If excessively high gross stack temperature is recorded, consult the factory.
 - g. Make sure the air shutter is locked securely in place.
18. On burners with pilots, if adjustments are made in the air shutter, recheck the pilot to make sure its operation has not deteriorated. To do this, shut off the main valve, check the flame response signal by cycling the burner through several lightoffs.
19. Check each operating and limit control to be sure they function properly by lowering and raising the temperature setting on each of the controls, causing the burner to cycle on and off.
20. Record the following information for future use:
- a) Air shutter position _____
 - b) Manifold gas pressure _____" W.C.
 - c) Stack draft _____" W.C.
 - d) O₂ reading _____% (4-6%)
 - e) CO₂ reading _____% (8-9%)
 - f) CO reading _____% (less than .03%)
 - g) Stack temperature:
Gross _____°F.
Less ambient _____°F.
Net _____°F.
 - h) Combustion efficiency _____%

PVI FIREPOWER®

BG400 GAS BURNER START-UP (con't)

AIR ADJUSTMENT

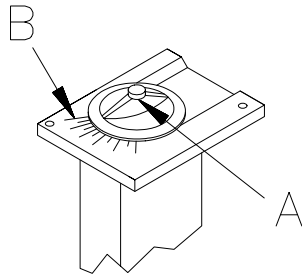

Loosen the locking screw and move the knob (A) along the scale (B) to the position wanted and tighten the screw. Check the air adjustment by making a flue gas analysis.

Figure 21A-3

GAS NOZZLE ADJUSTMENT

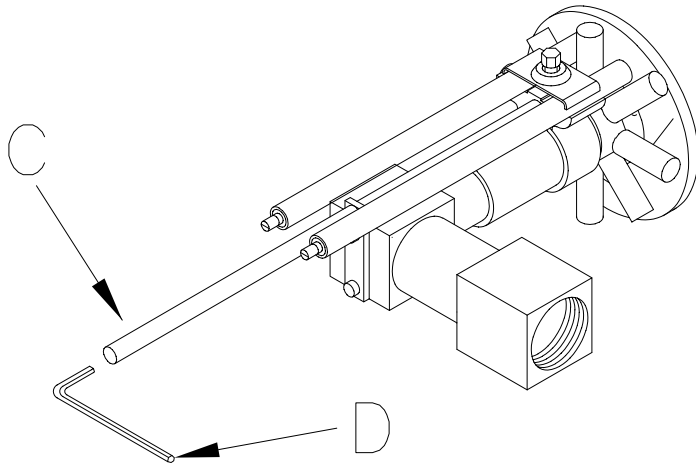

High carbon monoxide can be caused by a misaligned gas nozzle assembly. Turning the adjustment rod (C) clockwise will retract the gas nozzle assembly which can improve alignment.

Flame pulsation can be caused by poor flame retention. Turning the adjustment rod (C) clockwise will retract the gas nozzle assembly which will increase flame retention.

Retracting the gas nozzle assembly will restrict air flow thereby reducing the input of the burner. Any adjustments should be gradual.

Adjustment of the gas nozzle assembly is done using a 4mm Allen wrench (D) inserted through the hole in the sight glass.

Figure 21A-4

GAS NOZZLE ASSEMBLY REMOVAL DETAIL

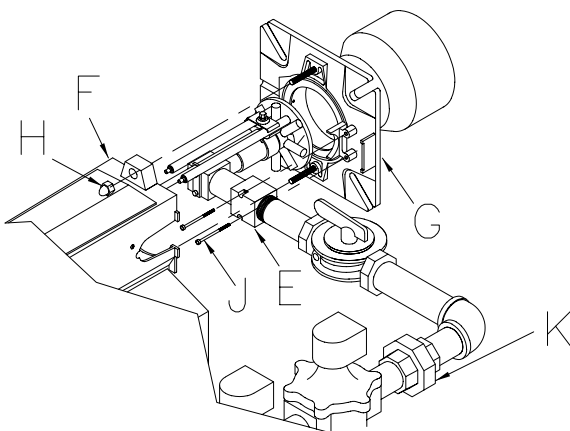

To remove the gas nozzle assembly (E), disconnect the gas train by breaking the union (K). Then remove the burner housing (F) by unscrewing the dome nut (H) located at the top and bottom of the housing. Disconnect the electrode wires without stressing the electrodes and support the burner housing while removing the nozzle. Now unbolt the nozzle by removing the two mounting bolts (J). Be careful not to break the electrodes while extracting the nozzle. It is not necessary to unbolt the flange (G) to maintain the burner.

Figure 21A-5

PVI FIREPOWER®
TROUBLESHOOTING SUGGESTIONS
BG400 GAS BURNER

1. BURNER FAILS TO START:

- A. **Defective on/off switch.** Replace switch.
- B. **Control circuit has open control contact.** Check limits, low water cutoff, and others as applicable.
- C. **Bad fuse or switch opens on incoming power source.** Correct as required.
- D. **Flame safeguard control safety switch tripped out.** Reset and determine cause of apparent flame failure.
- E. **Loose connections or faulty wiring.** Tighten all terminal screws and consult wiring diagram furnished with the heater.
- F. **Flame safeguard control starting circuit blocked due to flame relay being energized.** Possible defective scanner or flame rod - replace. Possible defective amplifier - replace. Scanner actually sighting flame due to leaking fuel valve - correct unwanted flame cause. Defective flame safeguard control - replace.
- G. **Defective blower motor.** Check for free rotation of fan wheel. Repair or replace.
- H. **Air proving switch is not properly adjusted.** Adjust per instructions on pg. 5, paragraph 1.

2. OCCASIONAL LOCKOUTS FOR NO APPARENT REASON:

- A. **Gas pilot ignition failure.** Check to see that ignition is instant and flame signal readings are stable and above minimum values. Use a manometer to make certain pressure is as recommended.
- B. **Loose or broken wires.** Check all wire nut connections and tighten all terminal screw connections in panel and elsewhere as appropriate.

- C. **With flame safeguard controls that incorporate the air flow switch in the non-recycling circuit,** ensure that when main flame lights, the air flow switch is not so critically set as to allow occasional momentary opening of the air switch contacts.
- D. **Occasional low supply voltage.** Contact local utility to correct. Make certain the burner control circuit transformer (if supplied) is correct for the voltage and power (VAC) being supplied.
- E. **Occasional low gas supply pressure.** Contact local utility to correct.

3. BURNER MOTOR RUNS, BUT PILOT DOES NOT LIGHT:

- A. **Gas supply to burner shut off.** Make sure all manual gas supply valves are open. Automatic high pressure valve at meter such as "Sentry" type tripped shut due to high gas pressure. Reset valve and correct cause for trip out.
- B. **Pilot solenoid valve not opening.** Listen and feel for valve actuation. **Solenoid valve not being powered.** Check electrical circuitry. Replace coil or entire valve if coil is burned out.
- C. **Defective gas pilot regulator.** Replace.
- D. **Gas pressure too high or too low at pilot orifice** (if supplied). Check orifice size in gas pilot assembly. Replace if incorrect. Readjust pressure as required.
- E. **Defective ignition transformer.** Replace. **Incorrect ignition electrode settings.** Readjust as required.
- F. **Defective flame safeguard control or plug in purge timing card.** Replace as required.
- G. **Air flow switch not making circuit.** Check out electrically. **Defective air flow switch.** Replace. **Air switch negative pressure sensing tube out of position.** Reposition as necessary.

PVI FIREPOWER®
TROUBLESHOOTING SUGGESTIONS
BG400 GAS BURNER (con't)

4. BURNER MOTOR RUNS & PILOT LIGHTS, BUT MAIN GAS FLAME IS NOT ESTABLISHED:

- A. **Main shutoff or test cock closed.** Check to make certain fully open.
- B. **Pilot flame signal reading too low to pull in flame safeguard relay.** Readjust as required.
- C. **Defective automatic main or auxiliary gas shutoff valves.** Check electrical circuitry to valves. Replace valves or correct circuitry as required.
- D. **Main diaphragm shutoff valve opening too slowly.** Adjust bleed on valve.
- E. **Defective flame safeguard control or plug on amplifier.** Check and replace as required.
- F. **Main gas pressure regulator atmospheric vent line obstructed.** Correct.
- G. **Defective main gas pressure regulator.** Replace. **Misadjusted main gas pressure regulator.** Readjust to meet required operational values.
- H. **Polarity reversed on incoming power.** (S89 control only.)

5. CARBON MONOXIDE READINGS ON GAS FIRING:

- A. **Flame impingement on "cold" heat transfer surfaces caused by excessive firing rate.** Reduce firing rate to correct input volume.
- B. **Incorrect gas/air ratios.** Readjust burner to correct CO₂ / O₂ levels, eliminate all CO formation.
- C. **Gas nozzle misadjusted.** Adjust nozzle per instruction in Figure 21A-4, page 7.

6. GAS HIGH FIRE INPUT CANNOT BE ACHIEVED:

- A. **Gas company pressure regulator or meter operating incorrectly, not allowing required gas pressure at burner train inlet.** Contact gas company to correct.
- B. **Gas cock upstream of train inlet not fully open.** Check and correct.
- C. **Gas line obstructed.** Check and correct.
- D. **Gas train main and/or lead test cocks not fully open.** Check and correct.
- E. **Gas supply line between gas company regulator and burner inlet too small.** Check supply pressure at meter, determine pressure drop and increase line size as required, or raise supply pressure to compensate for small line. Do not raise pressure so high that under static (no flow) conditions the pressure exceeds the maximum allowable pressure to the gas train components on the burner.
- F. **Gas nozzle misadjusted.** Adjust nozzle per instruction in Figure 21A-4, page 7.
- G. **Automatic gas valve not opening fully due to defective operation.** Replace gas valve.
- H. **Orifice (if supplied) too small.** Replace with correct size.
- I. **Defective main gas pressure regulator.** Replace.
- J. **Incorrect spring in main gas pressure regulator.** Replace as required.
- K. **Main gas pressure regulator vent line obstructed.** Check and correct.
- L. **Normally open vent valve (if supplied) not closing when automatic gas valves open.** Replace vent valve, if not closing fully.

Additional troubleshooting information can be found in the Flame Safeguard bulletin supplied with the burner.