

TURBOPOWER® OIL • PACKAGED WATER HEATER

AquaPLEX® STORAGE TANK (UNLINED DUPLEX ALLOY)

TANK SERIES 215 GALLONS

Model Number	Recovery gph ①		Input Btu/h	Gph #2 Oil	Max. oil gph (gear capacity) ④	Dimensions (inches)			Blower Motor		Shipping Weight lbs
	40°- 120°F	40°- 140°F				A	B	J ②	HP	Volt/Ph/Amps	
500 L 215A-TPO	500	400	399,000	2.8	70	27	5	17	1/2	115/1Ø/10	1340
750 L 215A-TPO	750	600	600,000	4.3	70	41	6	17	1/2	115/1Ø/10	1400
1000 L 215A-TPO	1000	800	800,000	5.7	70	41	8	17	1/2	115/1Ø/10	1440

- ① Recoveries based on 83% thermal efficiency. ASHRAE 90.1 compliant for efficiency and standby loss.
- ② "J" dimension is for the burner housing only.
- ③ 4" x 37 1/2" Channel skids for inputs ≤ 400 MBtu/h.
4" x 54 1/2" Channel skids for inputs ≥ 600 MBtu/h.
- ④ Standard gear capacities may change depending on burner supplier.
Designer must use gear capacities from the above chart to size the oil distribution piping system; including transfer pumps (if used).
Dimensions are in inches unless otherwise specified.
For standard and optional equipment, see form PV 8166.

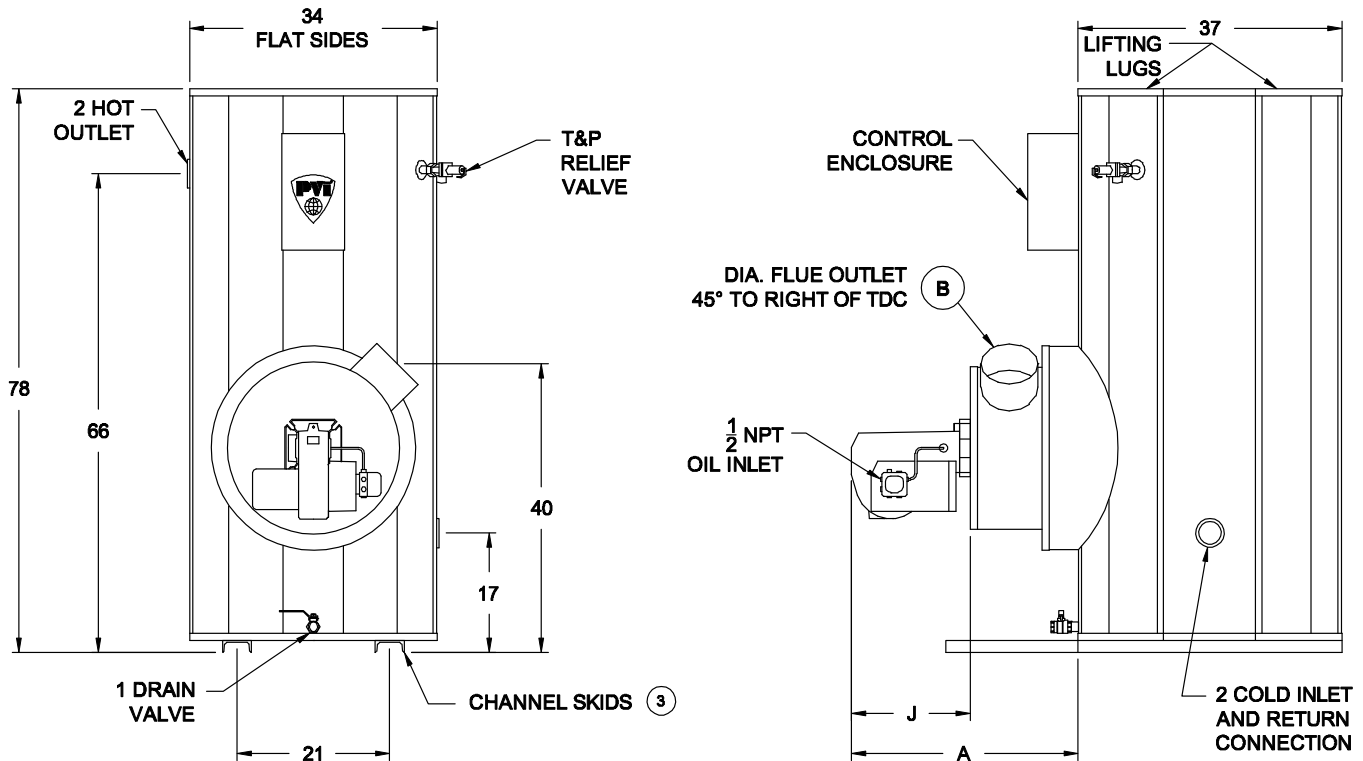

VENTING REQUIREMENTS

-.02" TO -.06" W.C. (NEGATIVE PRESSURE)

ENTIRE VENT SYSTEM SHOULD NEVER BE SIZED BASED UPON THE VENT CONNECTION DIAMETER EXCLUSIVELY. FOR PROPER SIZING, CONSULT VENTING SUPPLIER.

STANDARD ELECTRICAL REQUIREMENTS

CONTROL VOLTAGE: 120V, 1Ø, 60 HZ., 2 AMPS.
MOTOR VOLTAGE:
208V, 230V, AND 460V MOTORS ARE AVAILABLE BUT WILL REQUIRE A SEPARATE 120V/2 amps CONTROL CIRCUIT OR AN OPTIONAL CONTROL CIRCUIT TRANSFORMER.

PVI RESERVES THE RIGHT TO CHANGE THE DESIGN AND SPECIFICATION WITHOUT NOTICE.

