

Installation, Operation & Maintenance Manual

TURBOPOWER® 96 Water Heater with EOS (Electronic Operating System) Models (50, 75, 100, 130, 160) L (250-1500) A-TPX



Important: This manual contains information required for installation, operation and maintenance of this equipment. Read and follow the information in this manual and all other provided instructions, labels and markings before installing, operating or servicing this unit.

Installation and service must be performed by a qualified service installer, service agency or the gas supplier.

To the installer: After installation, these instructions must be given to the equipment user or left near the appliance.

Special instructions to the owner: Retain this manual for future reference. These instructions contain important information that will help you in maintaining and operating this appliance.



Hot Water Solutions

TURBOPOWER® 96 WATER HEATER

TABLE OF CONTENTS

- 1. Safety Considerations**
- 2. Product Description**
- 3. Water Heater Installation**
 - 3.1 Checking Equipment Before You Install
 - 3.2 Codes
 - 3.3 Electrical Requirements
 - 3.4 Handling and Locating the Water Heater
 - 3.5 Clearances to Combustible Surfaces
 - 3.6 Service Clearances
 - 3.7 Other Codes and Regulatory Clearances and Requirements
- 4. General Piping Guidelines**
 - 4.1 Inlet and Outlet Connections
 - 4.2 Building Return Piping
- 5. Condensate Drain, Trap & Disposal**
 - 5.1 Condensate Neutralization System (optional)
- 6. Gas Supply and Piping**
 - 6.1 Gas Train and Controls Certification
 - 6.2 Gas Control Trains
 - 6.3 Inlet Pressure
 - 6.4 Gas Piping Size
 - 6.5 Appliance Isolation During Gas Supply Piping Pressure Test
 - 6.6 Gas Connection
- 7. Combustion and Ventilation Air**
 - 7.1 Equipment Located in Confined Spaces
 - 7.2 Maximum Allowed Remote Combustion Air Inlet Length
 - 7.3 Remote Combustion Air Cap
 - 7.4 Vertical or Horizontal Remote Air Duct Termination
 - 7.5 Combining Remote Air Ducting
- 8. Venting**
 - 8.1 Venting the TURBOPOWER 96
 - 8.2 Maximum Vent Length
 - 8.3 Vertical or Horizontal Vent Termination
 - 8.4 Combining Category IV Vent
- 9. Operating and Safety Controls**
 - 9.1 Temperature and Pressure Relief Valve(s)
 - 9.2 Cathodic Protection
 - 9.3 Electronic Low Water Cut-off
 - 9.4 Operating Temperature Control
 - 9.5 High Water Temperature Limit Control
- 10. EOS (Electronic Operating System)**
 - 10.1 Touch Screen User Interface
 - 10.2 Status Field Display
 - 10.3 Operational Sequence Field Display
 - 10.4 View Menu (Home Screen - Default Display)
 - 10.5 Control System Menus
 - 10.6 Changing the Vent Material Type
 - 10.7 Changing the Operating Set Point
 - 10.8 Setting the Real Time Clock
 - 10.9 Scheduled Setback

TURBOPOWER® 96 WATER HEATER

- 10.10 Using the Manual Override Menu
- 10.11 Potentiometer (Operating Set Point for Standalone Operation)
- 10.12 Using Tool Box Menu
- 11. Communications And Diagnostics**
 - 11.1 Indicators
 - 11.2 Alarm Messages – Diagnostic Codes (Flashes)
 - 11.3 Replacing The Fuse
 - 11.4 Self-Check/Control Failure
 - 11.5 System Safety Checks
 - 11.6 Flame Current Measurements
 - 11.7 Non-Volatile Lockout/Manual Reset
 - 11.8 ID Card
- 12. Networking**
- 13. Remote Connections – Terminal Strip**
 - 13.1 Making BMS/BAS Remote Connection for Analog and Binary Signals
 - 13.2 Terminal Functions
- 14. Sequence of Operation**
- 15. Initial Startup**
 - 15.1 Initial Startup Requirements
 - 15.2 Tools and Instrumentation Required
 - 15.3 Resources
 - 15.4 On Site Considerations
 - 15.5 Startup Procedure
- 16. Potentiometer (Operating Setpoint for Stand Alone Operation)**
- 17. Troubleshooting Procedure**
 - 17.1 General Troubleshooting
 - 17.2 LED Error Code Listing
- 18. Replacement Parts**
 - 18.1 Blower & Burner Assembly
 - 18.2 Control Panel Components
 - 18.3 Gas Train Assembly
 - 18.4 Drain Valve – T&P Relief Valve – Integral Circulating Pump Assembly
 - 18.5 Component Wiring and Conduit Routing Details
- 19. Periodic Maintenance**
- 20. Recommended Maintenance Schedule**
- 21. Requirements for the Commonwealth of Massachusetts**

TURBOPOWER® 96 WATER HEATER

1. SAFETY CONSIDERATIONS

WARNING: If the information in the supplied manual(s) is not followed exactly, a fire, explosion or exposure to hazardous materials may result, causing property damage, personal injury or death.

AVERTISSEMENT. Assurez-vous de bien suivre les instructions données dans cette notice pour réduire au minimum le risque d'incendie ou d'explosion ou pour éviter tout dommage matériel, toute blessure ou la mort

FOR YOUR SAFETY

- **Do not** store or use gasoline or other flammable vapors or liquids in the vicinity of this or any other appliance.
- **Ne pas** entreposer ni utiliser d'essence ou ni d'autres vapeurs ou liquides inflammables à proximité de cet appareil ou de tout autre appareil.

WHAT TO DO IF YOU SMELL GAS

- **Do not** try to light any appliance.
- **Do not** touch any electric switch; do not use any phone in your building.
- **Immediately** call your gas supplier from a location away from your building and the smell of gas. Follow the gas supplier's instructions.
- If you cannot reach your gas supplier, call the fire department.

QUE FAIRE SI VOUS SENTEZ UNE ODEUR DE GAZ:

- Ne pas tenter d'allumer d'appareil.
- Ne touches à aucun interrupteur; ne pas vous servir des téléphones se trouvant dans le bâtiment.
- Appelez immédiatement votre fournisseur de gaz depuis un voisin. Suivez les instructions de fournisseur.
- Si vous ne pouvez rejoindre le fournisseur, appelez le service de incendies.

Installation and service must be performed by a qualified installer, service agency or the gas supplier.

L'installation et l'entretien doivent être assurés ou un service d'entretien qualifié ou par le fournisseur de gaz.

This product contains, or may come to contain materials that have been identified as carcinogenic, or possibly carcinogenic to humans. Before installing, servicing or removing this product, read and follow the supplied instructions

Clearance in accordance with the local installation codes and the requirements of the gas supplier.

Dégagement conforme aux codes d'installation locaux et aux exigences du fournisseur de gaz.

Should overheating occur or the gas supply fail to shut off, turn off the manual gas control valve to the appliance.

En cas de surchauffe ou si l'alimentation en gaz ne s'arrête pas, fermez manuellement le robinet d'arrêt de l'admission de gaz.

WARNING: Installation and service must be performed by a qualified installer, service agency or the gas supplier, who must read and follow the supplied instructions before installing, servicing or removing this appliance. Refer to the information contained in this manual. Improper installation, adjustment, alteration, service or maintenance can cause property damage, personal injury, exposure to hazardous materials or death.

WARNING: Do not use this appliance if any part has been under water. Immediately call a qualified service technician to inspect the unit and to replace any part of the control system, all gas controls and all other items affecting safe appliance operation and which has been under water.

AVERTISSEMENT: N'utilisez pas cet appareil s'il a été plongé dans l'eau, même partiellement. Faites inspecter l'appareil par un technicien qualifié et remplacez toute partie du système de contrôle et toute commande qui ont été plongés dans l'eau.

WARNING: In an emergency shut the main gas supply valve to the appliance from a location safely away from the emergency. Failure to follow these instructions can cause property damage, personal injury, and exposure to hazardous materials or death.

TURBOPOWER® 96 WATER HEATER

PRODUCT SAFETY INFORMATION REFRACTORY CERAMIC FIBER PRODUCT WITH CRYSTALLINE SILICA

WARNING: This product contains or may come to contain crystalline silica, which has been identified by the International Agency for Research on Cancer (IARC) as carcinogenic to humans. This product also contains refractory ceramic fibers, which have been identified by the IARC as possibly carcinogenic to humans. Avoid breathing fiber particulates and dust.

RISKS:

- Air borne fibrous insulation is a possible cancer hazard by inhalation.
- Airborne crystalline silica may cause silicosis (lung disease) by inhalation.
- May cause temporary irritation to eyes, skin, and respiratory tract.

PRECAUTIONARY MEASURES:

- Minimize airborne fibers with engineering controls.
- Use NIOSH/MSHA approved respirators as required (see SDS).
- Wear long sleeved, loose-fitting clothing, eye protection and gloves.

FIRST AID MEASURES: (If any of the irritations listed persists, seek medical attention)

- Eyes: Flush with water.
- Skin: Wash with soap and warm water.
- Ingestion: Do not induce vomiting. Get medical attention if gastrointestinal symptoms develop.
- Inhalation: Remove to fresh clean air.

WARNING: If you are unfamiliar with the safe handling of refractory ceramic fiber products, or if you wish additional information prior to beginning any disassembly of the water heater or boiler that might expose refractory ceramic fiber materials, contact: Unifrax Corporation, 2351 Whirlpool Street, Niagara Falls, NY 14305-2413, 1-800-322-2293.

IDENTIFICATION OF REFRACTORY CERAMIC FIBER MATERIALS (RCF):

The burner assembly utilizes RCF material. (The RCF materials are located within the product and not generally exposed except during service, disassembly or assembly.)

IMPORTANT SAFETY NOTE

It takes only 5 seconds of skin contact with 140°F water to cause a second degree burn! You must protect against high water temperatures at all lavatories, tubs, showers and other points of hot water contact.

Accidental scalding from high water temperatures is a greater risk in some types of installations. Some examples are:

**HOMES FOR THE MENTALLY HANDICAPPED
HOMES FOR THE PHYSICALLY HANDICAPPED
HOSPITALS AND NURSING HOMES
ELDER CARE FACILITIES AND REST HOMES
ORPHANAGES AND CHILD CARE FACILITIES**

OTHER INSTALLATIONS - WHERE RESPONSE TO CONTACT WITH HOT WATER MAY BE SLOWER OR WHERE THE DANGER OF HOT WATER CONTACT IS GREATER.

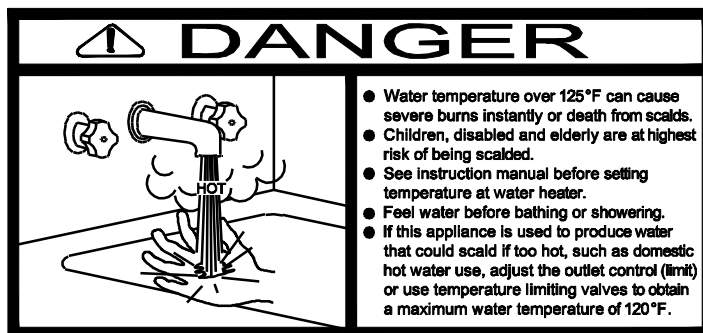

Thermostatically controlled mixing valves must be used in the design of the potable hot water system.

Potable hot water should be tempered to no more than 110°F when used for bathing or other personal uses.

Good engineering practice mandates the use of thermostatically controlled mixing valves set at 120°F or less to keep the delivered water temperature below scalding temperatures.

TURBOPOWER® 96 WATER HEATER

2 PRODUCT DESCRIPTION Component, Controls and Connection Locations (Locations May Vary)

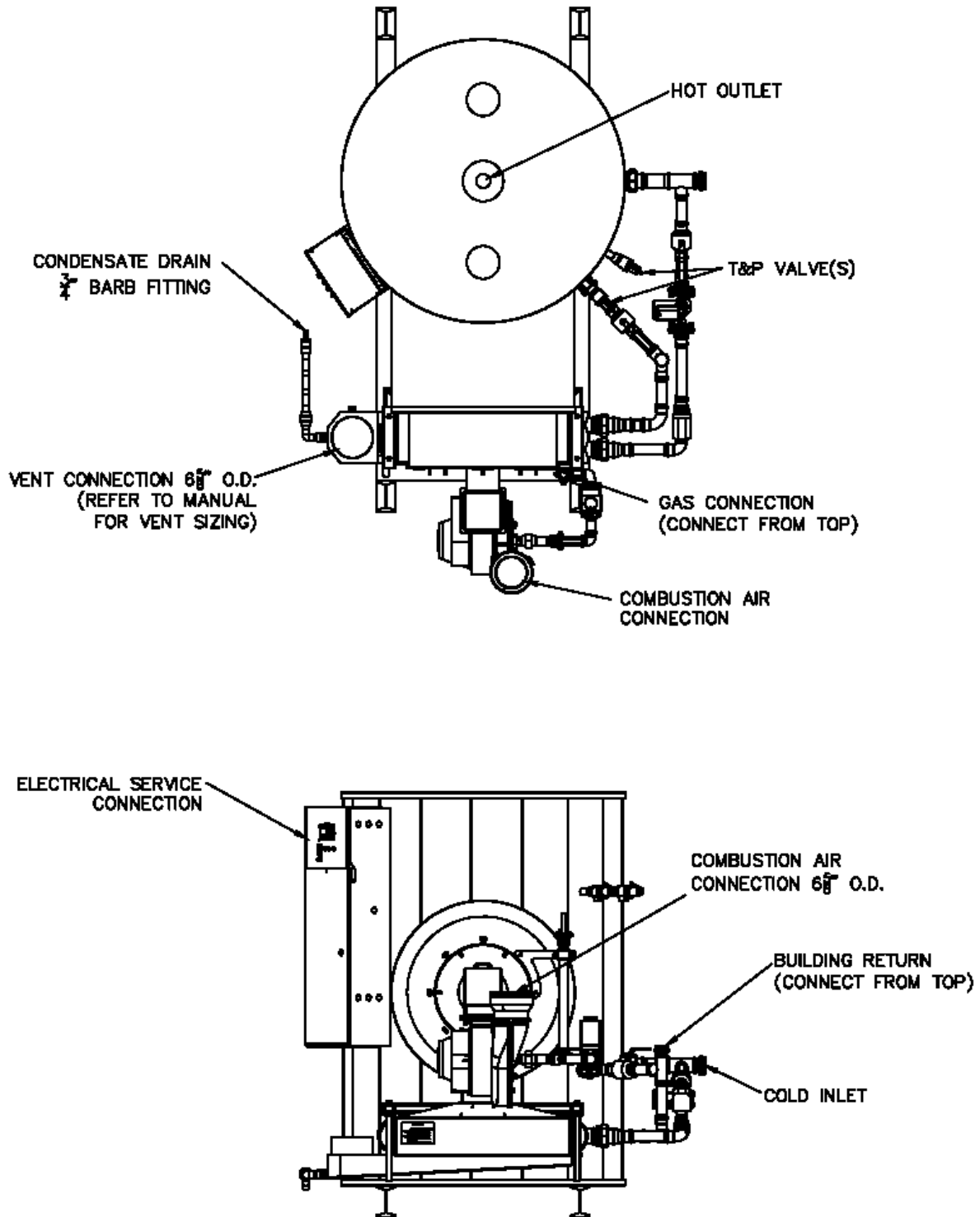

TURBOPOWER® 96 WATER HEATER

3 WATER HEATER INSTALLATION

3.1 Checking Equipment Before You Install

- Inspect the unit completely upon receipt from the freight carrier before signing the bill of lading. Inspect the appliance and all accompanying parts for signs of impact or mishandling. Verify the total number of pieces shown on packing slips with those actually received. Contact the freight carrier immediately if any damage or shortage is detected.
- Check the data decal on the appliance. Be sure the electrical, water and gas supply is adequate for the installation.
- Carefully remove all side and top shipping supports and bracing. If possible, do not remove the wooden base/skid assembly until the product has been moved to its final location for installation and operation (see: Handling and Locating the Water Heater).

3.2 Codes

The equipment must be installed in accordance with those installation regulations in force in the local area where the installation is to be made. Authorities having jurisdiction must be consulted before installation is made. In the absence of such requirements, the installation must be in accordance with the instructions in this manual, appliance markings and supplemental instructions and in compliance with the latest edition of the National Fuel Gas Code, ANSI Z223.1/NFPA 54. Where required by the Canadian authority having jurisdiction, the equipment must be installed in accordance with the latest edition of the CAN/CSA B149.1 Natural Gas and Propane Installation Code and applicable Provincial Regulations. All appliances conform to the current edition of the ASME Boiler and Pressure Vessel Code, Section IV, Part HLW.

3.3 Electrical Requirements

See appliance rating decal for electrical service requirements. The appliance must be electrically supplied and grounded in accordance with the requirements of the authority having jurisdiction or, in the absence of such requirements, with the latest edition of the National Electrical Code ANSI/NFPA No. 70. In Canada, the electrical service must conform to local electrical codes and/or CSA C22.1, Canadian Electrical Code, Part 1.

- All wiring between the unit and field installed devices must be made with properly rated stranded copper wire.
- Line voltage wire exterior to the appliance must be enclosed in approved conduit or approved metal clad cable.
- To avoid serious damage, **DO NOT** energize the unit until the system and appliance is full of water.

Utiliser du fil de cuivre de la taille appropriée pour le service électrique entrant. Les dommages résultant de l'utilisation de fil d'aluminium seront exclus du champ d'application de la garantie de cet appareil.

3.4 Handling and Locating the Water Heater

WARNING: Use industry standard safe rigging methods, such as strapping around the water heater base/skid assembly and using spreader bars, when attempting to lift or move this product. Failure to follow industry standard safe rigging methods can result in property damage, serious injury or death.

WARNING: This product should NOT be oriented in any direction other than vertical. Failure to comply may result in equipment damage not covered by the warranty.

1. The water heater must be located indoors.
2. Locate the water heater in an area that is not exposed to freezing temperatures.
3. Locate on a level surface. Although not generally required, a housekeeping pad may be necessary when additional elevation is required to properly drain condensate.
4. Locate the water heater near a floor drain. Locate the unit so if the tank or water connections should leak, water damage will not occur to the adjacent area or to lower floors of the building. When such locations are unavoidable, install an adequately drained metal drain pan underneath the water heater. The manufacturer's warranty does not cover water damage.
5. Protect associated electrical components and electrical connections from water (dripping, spraying, rain, etc.) during appliance operation and service.
6. Locate the water heater where the vent and air intake piping, when installed, will remain within the maximum equivalent lengths allowed. See Venting.
7. Use the attachment holes in the frame where the pallet is attached to locate anchors or attachment points, when connecting the heater to the floor.

TURBOPOWER® 96 WATER HEATER

3.5 Clearances To Combustible Surfaces

The minimum clearance to combustible material is 6" from the top, back and sides, and 24" from the front of the water heater.

Distance minimale aux matériaux combustibles est 15 cm sur les côtés, à l'arrière et de haut, avant les 61 cm et ne pas installé directement sur un plancher combustible.

3.6 Service Clearances

Additional clearance beyond the minimum required to combustible material should be considered to facilitate easy access for inspection and service of items such as the burner, gas controls and plumbing connections. Also allow sufficient space for installing and servicing building water, gas, vent, combustion air, electrical, pump and other auxiliary/optional equipment and connections.

3.7 Other Code and Regulatory Clearances and Requirements

Additional clearance beyond the minimum required to combustible materials and service recommendations may be required to comply with local, state or national codes and regulations. It is to the responsibility of the installer to comply with these requirements. Examples of codes or regulations that may apply are the National Electric Code, State/Regional/National drain water and flue emissions regulations, the National Fuel Gas Code, Building Construction and Safety Codes, the Americans with Disabilities Act (ADA) and, in states where a water heater above a certain input or storage capacity is considered a boiler, the applicable boiler code requirements, the applicable boiler installation requirements in "Safety Code for Controls and Safety Devices for Automatically Fired Boilers" (CSD-1) and other regulatory requirements.

4 GENERAL PIPING GUIDELINES

WARNING: Hot outlet and cold water piping materials connected to this product must be suitable for temperatures up to 212°F at normal operating water pressures.

4.1 Inlet and Outlet Connections

1. Use only non-ferrous water piping and fittings. Do not use galvanized pipe or fittings. Use of ferrous or galvanized pipe or fittings can cause rust to form. Do not use dielectric nipples.
2. Install shut-off valves and unions on the inlet and outlet water piping for servicing. Use caution when threading pipe nipples into tank connections to prevent cross threading, or over-tightening. Always use a back-up wrench on tank nipples when tightening unions, valves, etc.
3. Insulate hot water and return circulation lines. Insulate cold water supply lines if subject to freezing during shutdown periods. **IMPORTANT:** Do not use the plumbing connected to the appliance as a ground for welding or any other purpose.
4. Pipe the drain valve to a suitable open drain capable of receiving discharge temperatures up to 212°F.

IMPORTANT: For maximum efficiency, the inlet water to the TURBOPOWER 96 should not exceed 100°F. It is also recommended that the building return or dishwasher recirculation piping be connected to the return water connection located in the outlet plumbing of the condensing heat exchanger. The TURBOPOWER 96 utilizes cold inlet water to help extract almost all of the heat energy from the products of combustion, which lowers the vent temperature to allow the use of PVC vent pipe. Higher cold inlet water temperatures will reduce heater efficiency and increase the vent temperature. If the vent temperature approaches the maximum allowed, a vent temperature limit switch will cycle the heater off to protect the PVC vent. When high temperature inlet water is applied, follow the instructions for required venting selection and vent limit adjustment.

4.2 Building Return Piping

To maximize water heater efficiency, do not connect the building return or dishwasher recirculation piping directly to the cold inlet. Connect directly to the dedicated building return fitting in the outlet plumbing of the condensing heat exchanger. (~5 gpm)

TURBOPOWER® 96 WATER HEATER

LEGEND

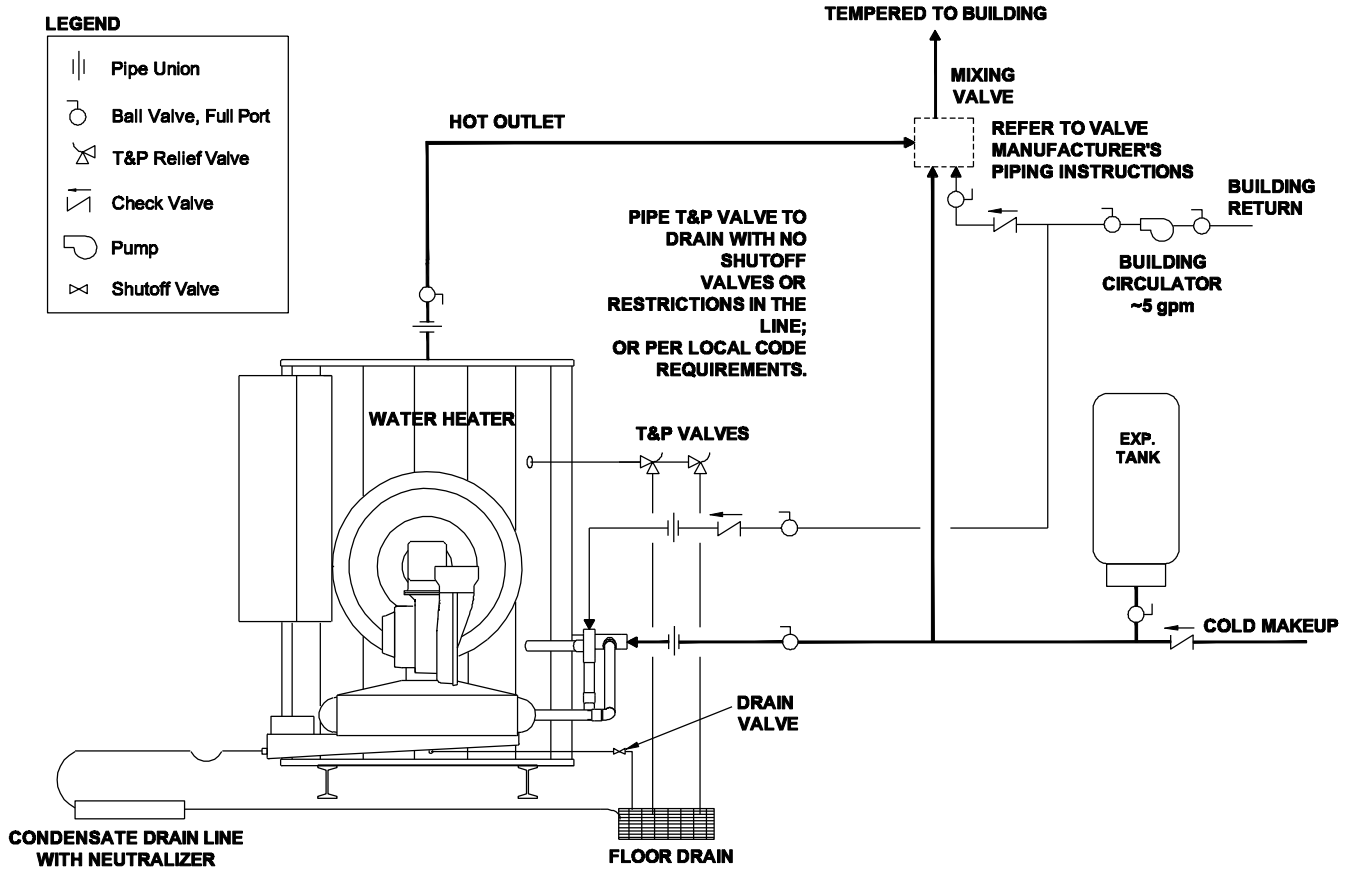
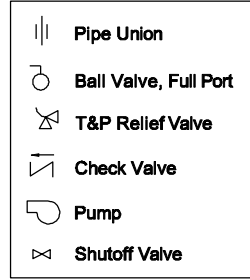

SINGLE WATER PIPING

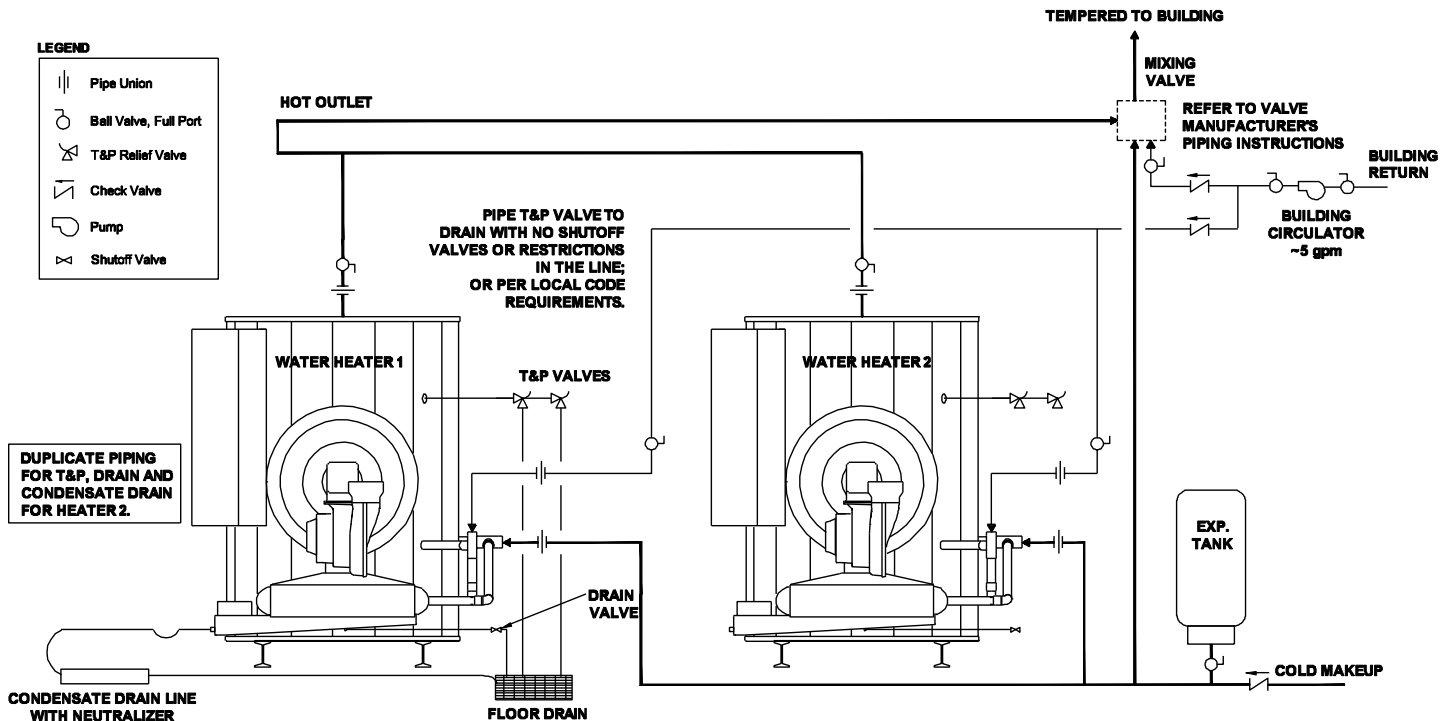

TWO WATER HEATERS WITH REVERSE RETURN PIPING

TURBOPOWER® 96 WATER HEATER

5 CONDENSATE DRAIN, TRAP & DISPOSAL

All TURBOPOWER 96 water heaters produce a significant amount of condensate. The condensate drain is under slightly positive flue pressure, so the provided 3/4" PVC condensate trap must always be used. This trap is sized and designed to fill with the proper amount of condensate to create a liquid barrier to prevent flue gases escaping through the condensate drain into the installed space.

WARNING: The trap included with this unit must be installed and maintained as described in these instructions and must be included as part of the condensate piping system. This trap is required to keep potentially hazardous products of combustion from continually entering the installed space where the condensate piping terminates. Failure to properly install this trap can cause, personal injury, exposure to hazardous materials or death.

1. The condensate trap assembly is disconnected from the water heater's condensate drain, at the union, prior to shipping.
2. The condensate drain exits the flue collector at the bottom rear of the water heater.
3. Connect the 3/4" CPVC union on the trap assembly to the CPVC union on the condensate drain. Ensure the trap is rotated to a vertical position (90 degrees from the floor).

NOTE: Additional CPVC fittings and pipe can be added to the condensate drain connection to relocate the condensate trap assembly as long as all added parts are at the same elevation of the condensate drain connection. **IMPORTANT:** Do not rotate the condensate drain connection (union) toward the ceiling. Do not use tools to tighten the CPVC union. Hand-tighten the CPVC union to seat the internal gasket.

4. Connect a 3/4" ID heavy wall Vinyl tubing rated for 170°F or higher condensate drain line, or a PVI Condensate Neutralization System to the barbed hose connection located at the end of the condensate trap. Alternatively, 3/4" PVC piping may be used for the condensate drain line.
5. All piping from the condensate trap to the suitable drain must remain below the top of the properly installed condensate trap outlet.
6. Do not combine condensate drains from multiple condensing appliances into a single drain line. Route each drain line into a drain suitable for condensate and make certain the end of the drain lines are not submerged or otherwise blocked.
7. All condensate plumbing must be protected from freezing. Do not locate the condensate piping such that an ice dam of frozen condensate can block condensate from leaving the outlet.
8. The condensate is only slightly acidic (3-5 PH), however, local codes may require it to be neutralized prior to entering the drainage system. An optional, field installed, Condensate Neutralization System is available from the factory.

Condensate Trap without Optional Condensate Neutralizer

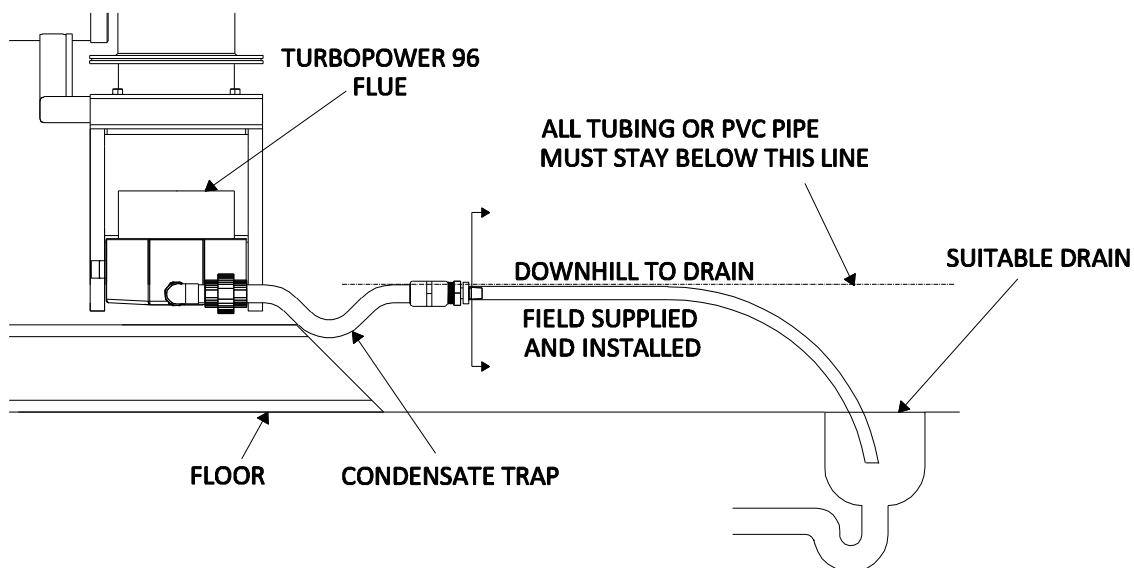

TURBOPOWER® 96 WATER HEATER

5.1 Condensate Neutralization System (optional)

Condensate is only slightly acidic (3-5 PH), however this slight acidity can be neutralized by routing it through an optional PVI Condensate Neutralization System. Some “authorities having jurisdiction” require such neutralization before condensate disposal through a suitable drain. Condensate is neutralized while slowly flowing through a container filled with renewable neutralizing media. The condensate neutralizer reduces or avoids the need for separate chemical treatment or dilution using substantial quantities of tap water. If the Condensate Neutralization System is used, a maintenance interval of 3 months should include checking for the following: adequate neutralization media, a fully closed system container, and any buildup of debris which could cause blockage in the system. Contact your local PVI representative to obtain a Condensate Neutralization System and follow the instructions included for assembly and connection.

Condensate Neutralization Systems (CNS) Installation Requirements:

1. Follow the steps in the Condensate Drain, Trap & Disposal section above.
2. The Condensate Neutralization System (CNS) must be mounted horizontally and level, with the mounting strap legs on the floor.
3. Locate the CNS in a convenient place between the condensate outlet and a suitable drain and where the threaded end cap can be removed to recharge the Neutralizer. Use only the replacement materials specified by the supplier of the CNS.
 - a. The CNS must be located such that condensate will flow downhill from the condensate trap outlet to the inlet on one end of the CNS and downhill from the other end of the CNS to the drain. If this continuous downhill flow is not maintained, the trap will not properly operate and condensate could back up into the heater.
 - b. Follow the instructions included in the Condensate Neutralization System for connecting the Vinyl tubing.
4. Keep the Condensate Neutralization System closed at all times, except for when the appliance is turned off for maintenance to recharge the condensate neutralizer with media.

WARNING: Keep the Condensate Neutralization System closed at all times the appliance is operating. The system must remain closed to prevent potentially hazardous products of combustion from continually entering the room. Failure to keep the Condensate Neutralization System closed during appliance operation can cause property damage, exposure to hazardous material, personal injury or death.

Condensate Trap with Optional Condensate Neutralizer Located On Same Level as TURBOPOWER 96

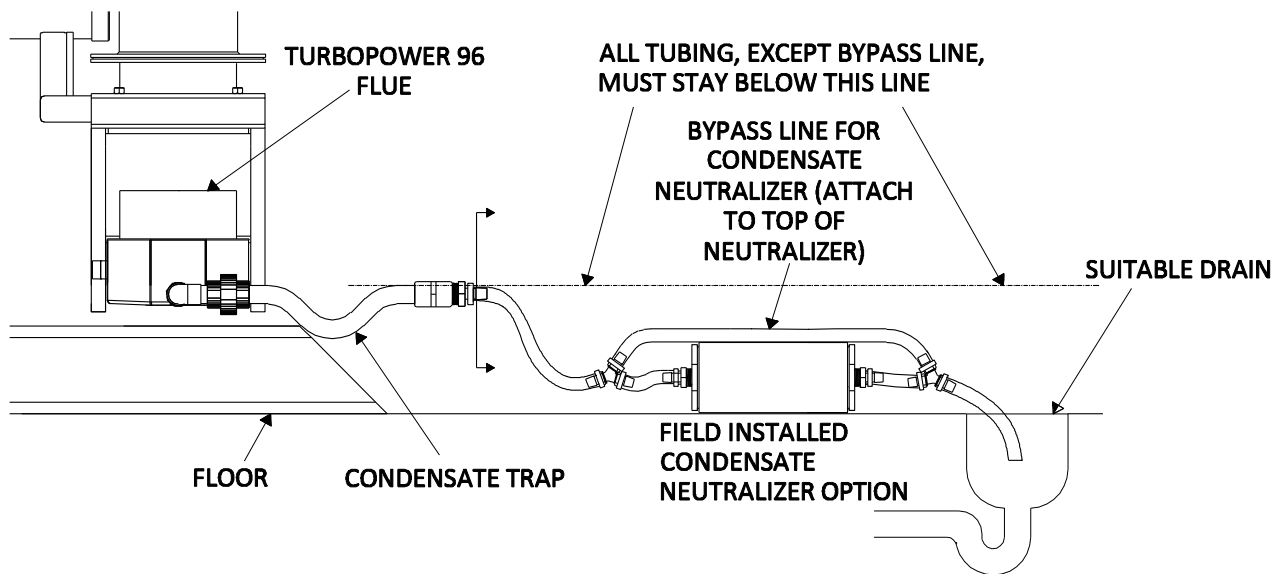

TURBOPOWER® 96 WATER HEATER

6 GAS SUPPLY AND PIPING

Verify the type of gas specified on rating plate is supplied to the unit. This unit is orificed for operation up to 2000 feet altitude. Appliance Btu/h input derates 4% per 1000 feet elevation above sea level. Consult Factory for installations above 2000 feet elevation.

6.1 Gas Train and Controls Certification

NOTE: The gas train and controls assembly provided on this unit have been tested under the applicable Nationally Recognized Standard to comply with safety and performance criteria such as ignition, combustion and safety shutdown operation.

6.2 Gas Control Trains

All models include the following gas control train components: manual shutoff valve, two safety shutoff valves, zero governor type regulator, and manual test valve. These components may be separate or combined in a common housing.

WARNING: Do not adjust or remove any screws or bolts on gas train control components which are secured with a red or blue sealing compound. In addition to voiding warranties and certification listings, such adjustment or disassembly can cause improper operation which could result in property damage, personal injury or death.

6.3 Inlet Pressure

Measure at the inlet pressure tap located at the main gas cock. The inlet pressure must remain within the minimum and maximum values while the unit is at rest and while the unit is operating at maximum firing rate.

INLET PRESSURE	NAT. GAS	Propane
Maximum Static Pressure (Inches-Water Column)	14.0"	11"
Minimum Flow Pressure (Inches-Water Column)	3.5"	4"

6.4 Gas Piping Size

Do not use the gas pipe connection size to determine the gas supply piping. Designing and sizing a gas supply piping system requires consideration of many factors and must be done by a gas supply piping expert. Always follow NFPA 54 National Fuel Gas Code for gas pipe sizing and gas pipe system design. The following charts provide examples of some of the information used by the gas supply piping expert to determine proper pipe sizes.

Use the values in the following table to add the equivalent straight pipe for each elbow or tee to obtain the total distance from the meter:

CONVERT FITTINGS TO EQUIVALENT STRAIGHT PIPE*								
Diameter Fitting (inches)	¾"	1"	1¼"	1½"	2"	3"	4"	5"
Equivalent Length of Straight Pipe (feet)	2'	2'	3'	4'	5'	10'	14'	20'

TURBOPOWER® 96 WATER HEATER

Use the following table to determine the possible pipe size based on distance from gas meter for a Single Unit Installation using Schedule Metallic Gas Pipe.*

Equivalent Feet From Meter	SINGLE UNIT INSTALLATION SUGGESTED PIPE SIZE Maximum Capacity for Natural Gas* MBTU/HR Based on 0.5" W.C. Pressure Drop**					
	1-1/4"	1-1/2"	2"	2½"	3"	4"
25	860	1320	2475	3900	7000	-
40	660	990	1900	3000	5300	-
60	-	810	1520	2400	4300	-
80	-	690	1300	2050	3700	-
100	-	620	1150	1850	3250	6700
125	-	-	1020	1650	2950	6000
150	-	-	950	1500	2650	5500
175	-	-	850	1370	2450	5000
200	-	-	800	1280	2280	4600

*See NFPA 54 National Fuel Gas Code for actual pipe size selection and for sizing Propane gas piping

MULTIPLE UNIT INSTALLATIONS SCHEDULE 40 METALLIC GAS PIPE SIZE CHART*														
Maximum Capacity of Pipe in Thousands of BTU's per hour for gas pressures of 14 Inches Water Column (0.5 PSIG) or less and a pressure drop of 0.05 Inch Water Column (Based on NAT GAS, 1025BTU's per Cubic Foot of Gas and 0.60 Specific Gravity).*														
Nominal Iron Pipe Size, Inches	Length of Pipe in Straight Feet													
	10	20	30	40	50	60	70	80	90	100	125	150	175	200
3/4	369	256	205	174	155	141	128	121	113	106	95	86	79	74
1	697	477	384	328	292	267	246	256	210	200	179	164	49	138
1 1/4	1400	974	789	677	595	543	502	472	441	410	369	333	308	287
1 1/2	2150	1500	1210	1020	923	830	769	707	666	636	564	513	472	441
2	4100	2820	2260	1950	1720	1560	1440	1330	1250	1180	1100	974	871	820
2 1/2	6460	4460	3610	3100	2720	2460	2310	2100	2000	1900	1700	1540	1400	1300
3	11200	7900	6400	5400	4870	4410	4000	3800	3540	3300	3000	2720	2500	2340
4	23500	16100	13100	11100	10000	9000	8300	7690	7380	6870	6150	5640	5130	4720

*See NFPA 54 National Fuel Gas Code for actual pipe size selection and for sizing Propane gas piping

6.5 Appliance Isolation during Gas Supply Piping Pressure Test

1. The appliance and its provided manual shutoff valve must be disconnected from the gas supply piping system during any pressure testing of that system at test pressures in excess of ½ PSI (3.5 kPa).
2. The appliance must be isolated from the gas supply piping system by closing its individual manual shutoff valve during any pressure testing of the gas supply piping system at test pressures equal to or less than ½ PSI (3.5 kPa).
3. The appliance and its gas connection must be leak-tested before placing it in operation.

6.6 Gas Connection

1. Safe operation of unit requires adequate gas supply with the required static and dynamic (flow) pressures. Actual piping selection depends on many variables that must be carefully considered by the gas piping system designer.
2. Do not select gas pipe sizes based only on the supplied tables. These tables are for use by the gas piping system designer as a reference in checking pipe size selections.
3. Gas pipe size may be larger than heater connection.
4. Installation of a union is suggested for ease of service.
5. Install a manual main gas shutoff valve on the gas supply piping connected to the appliance to isolate the burner and gas train from main supply gas in compliance with NFPA 54 National Fuel Gas Code and most local Codes.
6. The gas system installer must clearly identify the emergency shut-off device.
7. A sediment trap (drip leg) MUST be provided in the inlet of the gas connection to the unit.
8. The combination gas valve incorporates an internal vent limiter. Venting to outdoors is not allowed.

7 COMBUSTION AND VENTILATION AIR

TURBOPOWER® 96 WATER HEATER

Provisions for adequate combustion and ventilation air to the mechanical room must be in accordance with Section “Air for Combustion and Ventilation” in the latest edition of the NFPA 54 National Fuel Gas Code, ANSI Z223.1 and/or CAN/CSA B149.1, Installation Codes or applicable provisions of the local building codes. Any method addressed in NFPA 54 National Fuel Gas Code section “Air for Combustion and Ventilation is acceptable and several are outlined below.

7.1 Equipment Located In Confined Spaces

Equipment located in confined spaces requires two openings, one commencing within 12” (30.5 cm) from the top of the enclosure/room and one commencing within 12” from bottom of the enclosure/room to assure adequate combustion air and proper ventilation. The total input of all gas utilization equipment installed in the room must be used to determine the required minimum air volume needed for combustion, ventilation and dilution of flue gasses. Also consider makeup air requirements from other equipment within the mechanical room or other rooms that are pressure connected with the mechanical room. Some examples of other makeup air requirements are from kitchen exhaust hoods, clothes dryers, powered exhaust fans, etc.

- **All Air From Outdoors:**

Each opening requires a minimum free area of 1 square inch per 4000 Btu/hr of the total input rating of all appliances in the enclosure, if directly communicating with the outdoors or communicating to the outdoors through vertical ducts.

Each opening requires a minimum free area of 1 square inch per 2000 Btu/hr of the total input rating of all appliances in the enclosure, if communicating with the outdoors through horizontal ducts.

- **All Air from Inside the Building:**

Follow the requirements of NFPA 54 National Fuel Gas Code, ANSI Z223.1 section “Indoor Combustion Air.”

- **Combination of Air from the Indoors and from the Outdoors:**

Follow the requirements of NFPA National Fuel Gas Code, ANSI Z223.1 section “Combination Indoor and Outdoor Combustion Air.”

- **From Outdoors Through One Opening:**

Follow the requirements of NFPA National Fuel Gas Code, ANSI Z223.1 section “One Permanent Opening Method.”

- **Remote Air Intake System:**

This unit may be installed with a remote air intake system which uses a make-up air duct to draw combustion air directly from outdoors.

NOTE: Use of double-wall vent or insulated material for the combustion air inlet pipe is recommended in cold climates to prevent the condensation of airborne moisture in the incoming combustion air.

WARNING: Adequate clean combustion air must be provided to the appliance. The appliance must never operate under a negative pressure. Particular care must be taken when exhaust fans, compressors, air handling units, etc. may rob air from the appliance. The combustion air supply must be completely free of any chemicals or fumes, which may be corrosive to the appliance. Some common chemical fumes to avoid are fluorocarbons and other halogenated compounds, most commonly present as refrigerants or solvents, such as Freon, trichloroethylene, perchlorethylene, chlorine, etc. These chemicals, when in contact with the equipment or when burned, form acids which quickly attack the tubes, flue collector, stack and other appliance and auxiliary equipment. Failure to provide adequate clean combustion air or operating under negative pressure can cause premature, unwarranted product failure or unsafe operation producing carbon monoxide that could escape into the building. Exposure to carbon monoxide can lead to personal injury or death.

TURBOPOWER® 96 WATER HEATER

7.2 Maximum Allowed Remote Combustion Air Inlet Length (Equivalent Length)

A vertical or horizontal remote air inlet system can be connected to this appliance without modification. The maximum length of field supplied single wall pipe, such as galvanized ventilation pipe, is shown in the chart below titled Maximum Air Inlet Duct Equivalent Length. Use metal tape or RTV sealant to seal each pipe joint.

Maximum Allowable Equivalent Duct Length / Max Elbows		
Duct Size	6" Duct/	8" Duct
Max Equivalent Length all Models	100 feet/8	150 feet/8

To determine the maximum straight length of duct allowed, use the Duct Fitting Equivalent Length chart below to find the total equivalent length for all duct fittings in your combustion air system. Then subtract this number of feet from the total equivalent length allowed in Maximum Air Inlet Duct Equivalent Length chart above. The sum of this calculation is the maximum length of straight duct allowed. If a longer length is required, repeat the calculation using a larger duct size. No additional deduction is required for the addition of the duct system terminal.

Duct Pipe:	6" Duct	8" Duct
90° Elbow	20 feet	10 feet
90° Long Radius Elbow	12 feet	6 feet
45° Elbow	12 feet	6 feet

The following remote air duct information is provided for use in design calculations, if needed.

Remote Air Duct Specifications	
Input MBtu/h	Required Air (SCFM)
399/500	90/110
750/1000	165/220
1300/1600	265/350

7.3 Remote Combustion Air Cap

A suitable remote air termination must be used to prevent water, debris, animals or obstructing material from entering the remote air supply.

7.4 Vertical or Horizontal Remote Air Duct Termination

- Air inlet must be located no less than 3 feet (0.91m) below the exhaust terminal if they are within 10 feet (3.05 m) of each other, unless the flue outlet terminates with a straight discharge. If the flue outlet terminates with a straight discharge, the air inlet can be located no less than 18 inches (0.46m) below the exhaust terminal.
- If terminating through the roof, the air inlet must terminate at least 12 inches (0.3 m) above roof level and at least 12 inches (0.3 m) above snow levels.
- If terminating through a sidewall, the air inlet must terminate at least 12 inches (0.3 m) above grade and/or at least 12 inches (0.3 m) above possible snow levels.

TURBOPOWER® 96 WATER HEATER

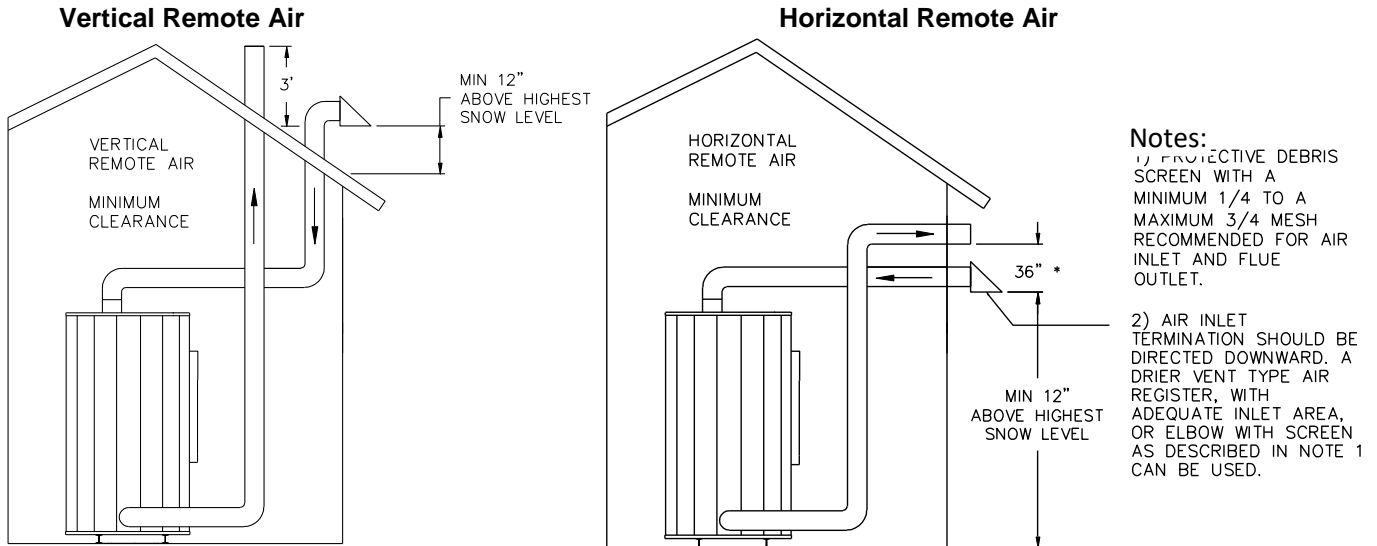

* When flue outlet is terminated with a straight discharge, separation of terminations must be a minimum of 18".

7.5 Combining Remote Air Ducting

Each water heater **MUST** have separate intake piping, unless the air inlet piping, exhaust duct and other system considerations have been fully evaluated and a combined duct system designed by one of the duct design firms identified at www.pvi.com/resources/documents-and-tools. Before operation of a combined remote air ducting system, all of the duct design firm's system installation and operation requirements must be in place, their instructions followed and the system must be properly maintained.

Combined TURBOPOWER 96 air intake piping must incorporate a variable speed blower capable of providing and regulating positive pressure air supplied to all water heaters in the system. **The pressure of the supplied air must not be less than 0.0 W.C. and must not exceed 0.25" W.C.**

The common combustion air supply system must be interlocked, so the water heaters will not begin operation until the common combustion air supply is proved to be within the range of 0.0 to 0.25" W.C. See Section on **Remote Connections** for a discussion of how to connect the proving circuit.

WARNING: Do not combine remote air ducting of multiple appliances into a single remote air duct unless the combined remote air ducting system has been evaluated and designed by a specified duct design firm and the combined remote air duct system is installed, operated and maintained following instructions from that firm. Combining remote air ducting without following these requirements can result in failure of the water heater and venting system and/or exposure to carbon monoxide and can result in property damage, personal injury or death.

TURBOPOWER® 96 WATER HEATER

8 VENTING

8.1 Venting the TURBOPOWER 96:

All TURBOPOWER 96 models use the positive pressure generated by the burner system blower to push combustion products out of the vent. Since the vent system is under positive pressure and must be capable of containing condensate, it must be constructed of schedule 40 solid PVC or CPVC pipe. Do not use PVC or CPVC pipe with cell/foam type construction (such as “CellCore”) or other non-solid PVC or CPVC plastic pipe. Polypropylene or single or double wall stainless steel venting listed by ETL, UL, ULC or CSA for Category IV positive pressure gas appliance venting may be used instead of solid PVC or CPVC plastic pipe venting.

IMPORTANT: If the cold inlet water temperature is above 100°F, then solid CPVC or ETL, UL, ULC or CSA listed polypropylene or stainless steel venting is required and the vent limit switch must be adjusted for the higher temperature rating allowed by these vent materials. (See Section 10.6 – Changing the Vent Material Type.)

Utilisez une catégorie IV PVC, CPVC ou ETL, UL, ULC ou CSA acier inoxydable ou inscrits conduit d'évacuation en polypropylène. Ne sélectionnez pas la taille du tuyau de ventilation basée uniquement sur le diamètre raccord de l'appareil.

Follow the instructions below for installing solid PVC or CPVC pipe. For other listed vent materials, follow the vent manufacturer's instructions for installation, sealing, supporting and terminating their vent system. Do not insulate plastic vent pipe.

The stainless steel vent connection located near the front of the water heater is 6-5/8" O.D., to accept a 6 inch PVC or CPVC pipe coupling. A reducer coupling may also be used to accommodate smaller or larger vent pipe. (See Maximum Vent Length tables). Do not use a barometric damper with the TURBOPOWER 96 positive pressure vent.

The TURBOPOWER 96 water heater can be vented either vertically, through a ceiling or roof, or horizontally through a wall. The TURBOPOWER 96 is a Category IV positive pressure gas appliance venting and can be routed to the outdoors in any direction, from the flue outlet of the water heater, except down. The vent must be installed and supported at least every four feet to slope downward toward the water heater vent connection with at least ¼ inch drop per linear foot of horizontal vent run, to allow proper drainage of accumulated condensation. The venting system shall also have means for collection and disposal of condensate. All penetrations through walls and roofs must be weather and gas tight, such that rain and products of combustion cannot pass from outdoors back indoors.

Additional steps required when venting with solid PVC or CPVC pipe:

1. Read and follow the information, instructions and warnings in “VENTING” section.
2. Do not insulate the plastic vent pipe.
3. Design the vent pipe route so that normal expansion (pipe getting longer) and contraction (pipe getting shorter), due to on and off temperatures, does not bind or put stress on cemented pipe fittings.
4. A 4 inch pipe coupling must always be the first fitting attached to the TURBOPOWER 96 vent connection when using a PVC or CPVC vent system. If a listed stainless steel or polypropylene Category IV vent system is used, the correct adapter for attaching and sealing to the TURBOPOWER 96 6-5/8 inch O.D. vent connection must be obtained from the manufacturer of the vent system to be installed.
5. For PVC or CPVC, dry-fit the 6" pipe coupling onto the TURBOPOWER 96 vent connector. Then remove the coupling and apply a liberal coating of room temperature vulcanizing (RTV) adhesive to the outside of the vent connector and to the inside of the plastic pipe coupling. Before the RTV sets, slide the coupling over the vent connector while rotating approximately 1/8 of a turn. Inspect and apply additional RTV to the joints, if needed to provide a sound air and water tight seal.
6. Drill a pilot hole through the PVC or CPVC coupling flange and into the center of the stainless steel vent connector flange in three equally spaced locations around the pipe. Drive stainless steel sheet metal screws through the pilot holes to attach and firmly hold the plastic coupling onto the vent connector flange.
7. Clean and deburr all solid PVC or CPVC pipe ends, then trial assemble the entire vent system vent before joining with cement. Mark the pipe and fittings to identify their locations, then disassemble. Reassemble the vent system using fresh PVC cement to connect PVC pipe and fresh CPVC cement to connect CPVC pipe. If both solid PVC and solid CPVC pipe are used in the same vent system, all joints between the two types of pipe must be made with fresh cement suitable for both materials. Follow the cement manufacturer's instructions for making sound air and water tight joints.

TURBOPOWER® 96 WATER HEATER

8. Vent support – For PVC or CPVC, the vent system must be supported at intervals no greater than four feet, to prevent sagging, distortion and stress on pipe fittings. Vertical pipe must also be supported to avoid stress on all cemented pipe fittings and to prevent putting excessive weight on the appliance vent connection. For listed stainless steel or polypropylene vent system, follow the vent system manufacturer's instructions.
9. Testing for leaks – Once the vent system is installed, it must be checked to confirm all joints in the vent system are air and water tight. After the vent is assembled, close the end of the vent with a taped plastic bag or some other temporary closure. With the gas supply turned off, energize the TURBOPOWER 96 combustion blower to apply air pressure to the vent system. Spray each joint and vent connection with commercially available leak detection liquid to confirm no air is escaping from any point. Repair any leaks and retest. After testing is complete, de-energize the combustion blower, wipe clean the leak detection liquid and REMOVE the temporary vent closure.
10. The vent pipe must be sealed at the point where it passes through a wall or roof, to prevent rain, insects or flue products from entering the living space or interior of the building.
11. For proper vent operation and to protect the gas vent from wind and weather, provide suitable termination to prevent wind, water, debris or animals from obstructing or entering the vent. The vent for this appliance shall not terminate:
 - 1) Over public walkways; or
 - 2) near soffits or crawl space vents or other areas where condensate or vapor could create a nuisance or hazard or cause property damage; or
 - 3) where condensate vapor could cause damage or could be detrimental to the operation of regulators, relief valves, or other equipment.
12. Do not use a barometric damper with the TURBOPOWER 96 venting system. Barometric dampers are designed for use with certain Category I negative pressure vent systems. The TURBOPOWER 96 uses certain Category IV positive pressure vent systems and will not operate safely with a barometric damper.

WARNING: Use only solid PVC or CPVC pipe or use Polypropylene or stainless steel venting (single or double wall) listed by a nationally recognized testing laboratory for Category IV positive pressure gas appliance venting. Use of ABS pipe, or use of PVC or CPVC pipe with cell/foam type construction or use of use of venting materials other than specified in these instructions can result in failure of the venting system and/or exposure to carbon monoxide or other toxic fumes, which can result in property damage, personal injury or death.

WARNING: Do not vent this water heater into an existing or traditional gas vent or chimney, do not combine the vent with any other appliance and do not use a barometric damper in the vent. Such venting could result in failure of the venting system and/or exposure to carbon monoxide which can result in property damage, personal injury or death.

8.2 Maximum Vent Length (Equivalent Length)

The maximum length of field supplied Category IV vent is shown in the chart below:

Maximum Allowable Equivalent Vent Length / Max Elbows		
Duct Size	6" Duct	8" Duct
Max Equivalent Length all Models	100 feet/4	150 feet/8

Pipe fittings reduce the maximum allowable vent length. Use the Category IV vent manufacturer's equivalent length deduction for all elbows, terminations, etc. If the information is not readily available from the vent manufacturer, use the Vent Fitting Equivalent Length chart below to find the total equivalent length for all vent fittings in your combustion air system. Then subtract this number of feet from the total equivalent length allowed in Maximum Category IV Vent Equivalent Length chart above. The sum of this calculation is the maximum length of straight vent allowed. If a longer length is required, repeat the calculation using a larger vent size. When using this chart, no additional deduction is required for the addition of the vent system terminal. The minimum vent length should be five feet without the addition of elbows or other fittings.

TURBOPOWER® 96 WATER HEATER

Vent Pipe Fitting Equivalent Length for all Models				
Vent Pipe:	PP *	Other **	PP *	Other **
	6" Vent	6" Vent	8" Vent	8" Vent
90° Elbow	22 feet	20 feet	11 feet	10 feet
90° Long Radius Elbow	14 feet	12 feet	5 feet	6 feet
45° Elbow	14 feet	12 feet	5 feet	6 feet

* PP = polypropylene

** Other = PVC, CPVC or Stainless Steel

The following vent information is provided for use in design calculations, if needed.

Venting Specifications		
Input MBtu/h	Combustion Air Volume (cfm)	Max Vent Press. " W.C.
500	135	1.0
750	202	1.0
1000	270	1.0
1300	351	1.0
1600	432	1.0

8.3 Vertical or Horizontal Vent Termination:

1. The vent terminal must have a minimum clearance of 4 feet (1.22 m) horizontally from, and in no case be located above or below, unless a 4 foot (1.22 m) horizontal distance is maintained from electric meters, gas meters, regulators and relief equipment.
2. The vent must terminate at least 3 feet (0.91 m) above any forced air inlet within 10 feet (3.05 m).
3. The vent shall terminate at least 4 feet (1.22 m) below, 4 feet (1.22 m) horizontally from or 1 foot (0.3 m) above any door, window or building air inlet to the building.
4. The vent system shall terminate at least 1 foot (0.3 m) above grade and at least 1 foot (0.3m) above possible snow accumulation levels and shall terminate at least 7 feet (2.13 m) above grade when located adjacent to public walkways or gathering areas.
5. To avoid a blocked flue condition, keep the vent cap clear of snow, ice, leaves, debris, etc. Inspection of the screens in vent termination should be performed periodically to clear debris.
6. The vent must not exit over a public walkway, near soffit vents or crawl space vents or other areas where condensate or vapor could create a nuisance or hazard or cause property or could be detrimental to the operation of regulators, relief valves or other equipment.
7. A horizontal vent must extend one foot beyond the wall and terminate at least two feet above the maximum expected snow accumulation.
8. A horizontal vent terminal must not be installed closer than 3 feet (0.91m) from an inside corner of an L-shaped structure.
9. A vertical vent must exhaust outside the building at least 3 feet (0.91m) above the point of the exit and at least 2 feet (0.61 m) above the highest point of the roof within a 10-foot (3.05 m) radius of the termination.
10. A vertical termination less than 10 feet (0.91 m) from a parapet wall must be a minimum of 2 feet (0.61 m) higher than the parapet wall.
11. Recommended to use an exit cone in lieu of a termination rain cap for normal installations and T-termination and H-termination for high-wind areas.

8.4 Combining Category IV Vents

1. Combined TURBOPOWER 96 Category IV gas vent systems must incorporate an Exhausto, Tjernlund or US Draft variable speed, modulating, mechanical draft inducer capable of maintaining the appropriate negative pressure at the end of the common flue, to assure that all water heaters in the combined vent system operate with a negative draft. **Do not exceed negative 0.25" W.C.** See "Combining Vents with a Draft Inducer" illustration below.

TURBOPOWER® 96 WATER HEATER

2. Combining the exhaust vents of multiple TURBOPOWER 96 condensing water heaters into a common, unpowered or “gravity” vent is never recommended (i.e. venting as Category II). TURBOPOWER 96 water heaters are too efficient and their flue products are too cold to generate the natural buoyancy required for such combined vent systems to function reliably and safely.
3. The common mechanical draft vent system must be interlocked, so the water heaters will not begin operation until the common mechanical draft vent system negative pressure is proved to be within the range of 0.04” and 0.25” W.C. See Section on **Remote Connections** for instructions for how to connect the proving circuit.

When combining the exhausts of multiple TURBOPOWER 96 water heaters do not use individual remote ducts to provide outdoor combustion air.

4. When exhaust vents are combined, it is necessary to either:
 - a. Draw all combustion air for each heater from the mechanical room in which they are installed, or
 - b. Use a common air supply system that is designed and installed by a qualified professional firm and that meets all the requirements contained in Subsection **Combining Remote Air Ducting**, which is located in the **COMBUSTION AND VENTILATION AIR** Section of this manual.

WARNING: Do not connect multiple water heaters vents into a single unpowered or fixed speed powered vent. This could cause unsafe operation and the potential for poisonous carbon monoxide to enter occupied areas. Such improper installation can cause property damage, exposure to hazardous materials, personal injury or death.

Conventional Venting

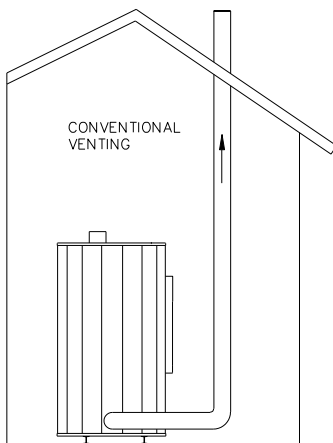

Through the Wall Venting

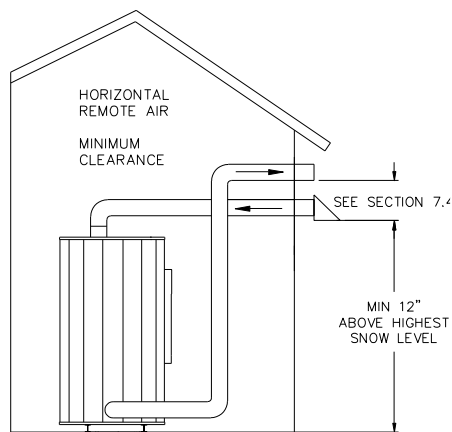

TURBOPOWER® 96 WATER HEATER

9 OPERATING AND SAFETY CONTROLS

9.1 Temperature and Pressure Relief Valve(s)

A Temperature and Pressure Relief Valve(s) sized in accordance with the ASME Boiler and Pressure Vessel Code, Section IV HLW is installed in the tank. Additionally, an ASME Section VIII 150 psi Pressure Relief Valve is installed in the inlet supply plumbing to the Economizer.

WARNING: Secure the relief valve discharge pipe to a suitable floor drain such that very hot water does not openly splash during a significant relief valve discharge. If the relief valve discharge pipe is not routed and secured to a suitable drain, hot water discharge can result in property damage, scalding and personal injury or death.

- Follow the temperature and pressure relief valve manufacturer's installation instructions and all local, regional and national codes applicable to temperature and pressure relief valve installation and discharge piping.
- The relief valve discharge pipe must not be smaller than the relief valve opening and must be secured to prevent it from lifting out of the drain under discharge pressure and must be routed to allow complete drainage of the valve and line.
- Do not plug the relief valve (s) or install a reducing coupling, valve or other restriction in the relief valve(s) discharge line(s), as this will eliminate the critical water temperature and pressure protection it provides.
- Thermal Expansion - A relief valve that periodically discharges may result from thermal expansion if the water heater is installed in a system closed by components, such as a backflow preventer or check valve in the cold water supply. These systems must be provided with means to control expansion. Contact a water heater or plumbing professional to resolve this situation.

WARNING: Do not plug the relief valve(s), use discharge piping smaller than the relief valve opening or install a reducing coupling, valve or other restriction in the relief valve discharge line. Failure to comply with these relief valve and discharge piping requirements can prevent the relief valve from providing its intended temperature and pressure protection, which can result in property damage, personal injury or death.

9.2 Cathodic Protection

PVI water heaters do not utilize cathodic protection. However, in hot water systems utilizing cathodic protection, hydrogen gas can be produced when the hot water system has not been used for a long period of time (generally two weeks or more). **Hydrogen gas is extremely flammable.** To prevent the possibility of injury under these conditions, one of the hot water system faucets should be opened for several minutes before using any electrical device connected to the hot water system. If hydrogen is present, there will be an unusual sound such as air escaping through the pipe as the hot water begins to flow. Do not smoke, have open flames or turn electrical switches on or off near the faucet at the time it is open.

9.3 Electronic Low Water Cut-Off

When the water level is above the electrode position in the tank, the reset pushbutton will energize the control (LED will be lit). The control remains energized until the water level drops below the electrode position (LED will not be lit). Unless otherwise specified, there is a three-second time delay on decreasing level. Water level must be below tank probe location for full three seconds before control de-energizes. In the event that a low water condition occurs, a failure message will be displayed on the controller touch-screen. This failure lockout can be reset by pressing the LWCO RESET button located on the front control panel. Hold the reset button in for 30 seconds to ensure a proper reset. Heater will operate when LWCO is cleared, EOS reset not required.

The Electronic Low Water Cut-Off probe is located on the side and at the top of the water heater tank and is accessible behind a removeable cover.

WARNING: Turn off all electrical service to the appliance when accessing the limit or other controls located inside the control cabinet or inside the burner vestibule inside the top of the appliance. Close and fasten the control cabinet and burner vestibule cover before restoring electrical service to the appliance. The cabinet and burner vestibule contain High Voltage wiring and terminals. If the electrical service is not turned off and these terminals are touched, a dangerous shock causing property damage, personal injury or death could occur.

Coupez l'alimentation avant intervention sur l'appareil.

TURBOPOWER® 96 WATER HEATER

9.4 Operating Temperature Control

The stored water temperature is adjustable through a Touch Screen User Interface located in the front control panel. The control is factory pre-set at approximately 120°F. See Water Heater Control Panel, **Section 10.1**, in this manual for more information.

Le thermostat est réglé à environ 49 degrés Celsius. Températures de l'eau supérieures à 52 degrés Celsius peut causer instantanément de graves brûlures ou la mort de brûlures. Suivez les instructions dans le manuel d'installation pour modifier la température de l'eau.

9.5 High Water Temperature Limit

The water heater Electronic Operating Control System (EOS) includes a single probe that contains a high water temperature limit and a completely separate upper tank operating sensor. Since both these sensors are in the same location in the heated storage tank, the EOS checks to be sure their output is within a degree or two of each other. If not, or if the maximum water temperature exceeds 200°F, the EOS will lockout and the manual reset button on the control panel must be pressed before the heater will resume operation.

TURBOPOWER® 96 WATER HEATER

10 THE ELECTRONIC OPERATING SYSTEM (EOS)

The TURBOPOWER 96 EOS consists of three components: The **Platform Ignition Module (PIM)**, plug-in **ID card** and the **Control Display**. The PIM is connected to the control display using an RJ485 patch cable. All communication between the PIM and control display as well as the power to the control display is through this cable.

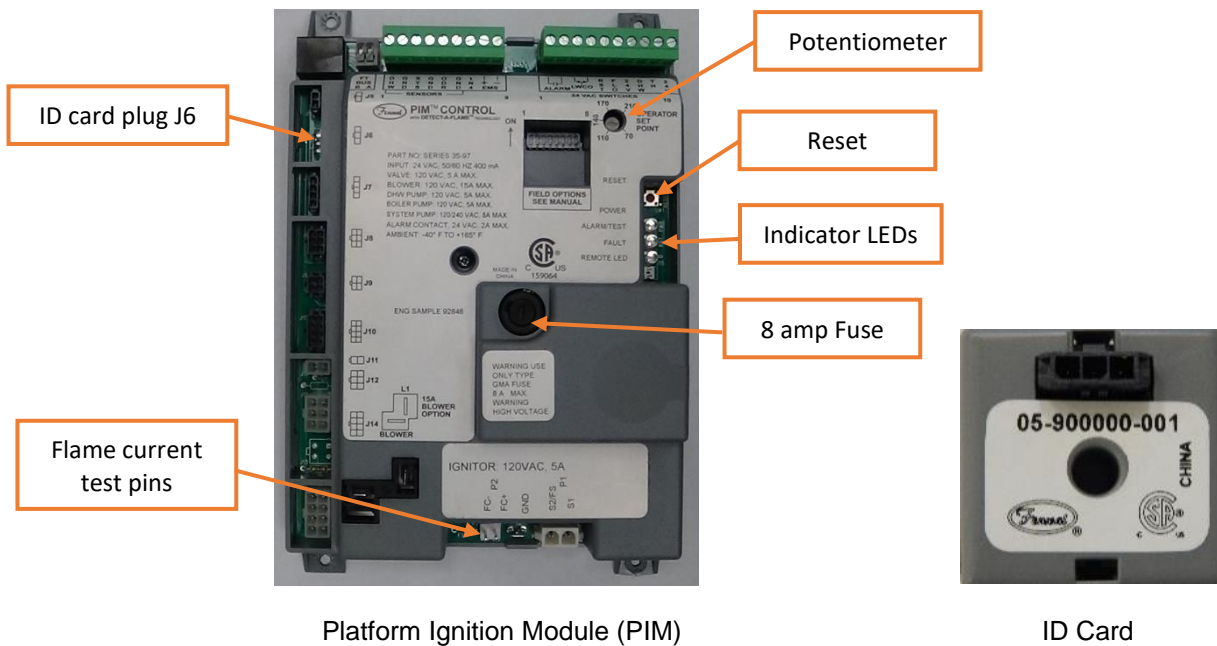

Platform Ignition Module (PIM)

ID Card

The stored water temperature is adjustable through a Touch Screen User Interface located in the front control panel. The control is factory pre-set at approximately 120°F. See Water Heater Control Panel, **Section 10.1**, in this manual for more information.

Le thermostat est réglé à environ 49 degrés Celsius. Températures de l'eau supérieures à 52 degrés Celsius peut causer instantanément de graves brûlures ou la mort de brûlures. Suivez les instructions dans le manuel d'installation pour modifier la température de l'eau.

Home Button.
Return to the 'Home' Screen from any menu.
Press and hold for 3 seconds to access the programming menus.

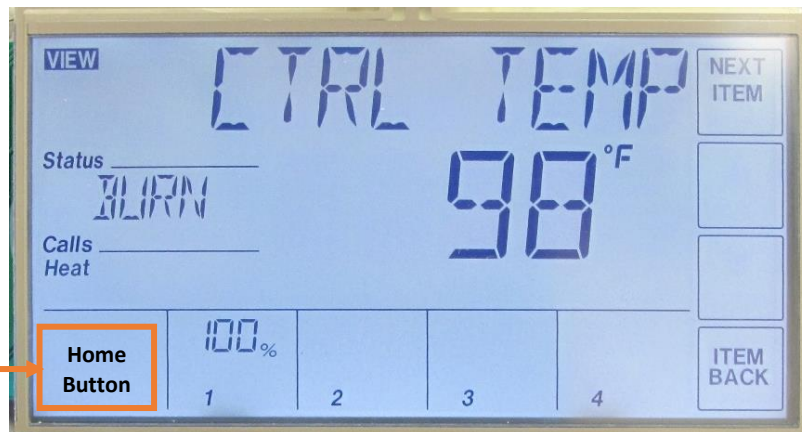

Digital Control Display with Touch Screen User Interface

10.1 Touch Screen User Interface

The touchscreen of the EOS provides one touch access to view and adjust various Menu set points. The touchscreen displays Status Fields, Items, Heater Output and Number Fields. It also contains buttons for navigation & adjustment, and the Home Button to access menu selections.

TURBOPOWER® 96 WATER HEATER

10.2 Status Field Display

The Status Field displays the current operating status of the control display. Most items in the status field are only visible when in the VIEW Menu or an alarm condition is present.

Item	Description
SANI	Sanitation Mode is active. Momentarily energizes a field installed sanitation pump and operates heater at an elevated setpoint temperature.
HAND	Hand Mode has been activated in the OVERRIDE Menu. This function allows the user to manually control the operation and firing rate of the burner.
OFF	The Off mode indicates that the system has been disabled in the OVERRIDE Menu.
PURG	The Purge mode indicates that individual pumps have been activated in the OVERRIDE Menu.
IDLE	The EOS is Idle do to no demand for heat.
ARSW	The EOS is attempting to purge but waiting for the blower speed tachometer to prove blower operation.
PREP	The EOS is Pre-Purging the burner system.
IGN	The Hot Surface Igniter is hot and the gas valve has opened to attempt burner ignition (4 seconds).
BURN	The Burner has ignited and the flame has been sensed.
POST	The Call for Heat has ended and the EOS is Post-Purging the burner system.

10.3 Operational Sequence Field Display

The EOS displays the following burner operational sequence, ignition status, timings, temperatures and values:

Item	Value Displayed	Description
SATISFIED	°F	No Call For Heat based on temperature sensed at control sensor at the top of the tank.
CALL FOR	READY	Initiated when the temperature sensed at the control sensor at the top of the tank is 5 degrees less than the setpoint temperature.
BLOWER	mm:ss	Displays the pre-purge time countdown until the igniter heat up begins.
IGNITION	mm:ss	Displays heat up time until gas valve opens.
CURRENT	0 - 10.0 µA	Flame Current (µA).
CTRL TEMP	°F	Flame is established and the temperature sensed at the control sensor at the top of the tank is displayed.
BLOWER	mm:ss	When the call for heat has ended, the post purge time countdown is displayed.

TURBOPOWER® 96 WATER HEATER

10.4 View Menu (Home Screen - Default Display)

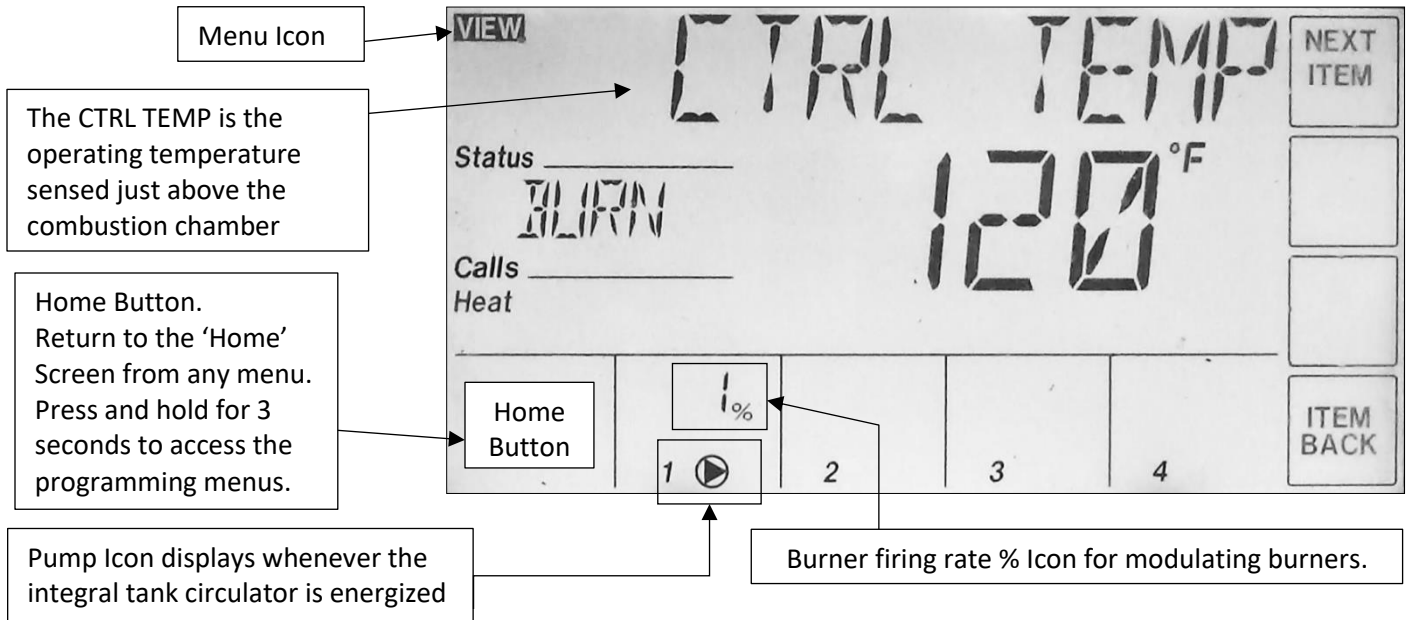

The **View Menu** is the default display (home screen) of the EOS control system. The View Menu displays general information about the water heater's operation and status. The default display includes a Burner Firing Rate % Icon for modulating units, a Pump Icon that is visible whenever the integral tank circulator is energized and Failure Messages if the unit is in an alarm or error condition.

Use the **Next Item** and **Item Back** buttons to scroll and view the View Menu Item Fields and their associated values. The Item Field descriptions are listed below:

Item Field	Description
SETPOINT	Display screen displays the current operating set point but does not allow the user to make changes in this menu.
VENT	Displays the current flue gas temperature as measured by the flue gas sensor located in the flue outlet.
TANK TOP	Displays the current temperature at the top of the water heater tank as measured by the operating control sensor located near the hot outlet.
TANK BOT	Displays the current temperature near mid tank of the water heater as measured by the control sensor responsible for regulating the operation of the integral tank circulator.
TANK ΔT	Displays the current temperature difference between the TANK TOP and the TANK BOT sensors.
FLAME CUR	Displays the burner flame current in approximate μA dc. Since this is an approximation it is recommended that a flame current measurement be taken at the PIM control board using a micro-amp meter or digital multimeter at the FC+ / FC- terminals 1VDC = 1 μA or 0.00001 Amp.
TIME	Displays the time of day. Set the time in the TIME menu. Visible if clock set and enabled.

TURBOPOWER® 96 WATER HEATER

10.5 Control System Menus

The control display has multiple access levels. System critical settings will not be available for adjustment. The settings which can be adjusted by the user will display UP and DOWN adjustment arrows on the right side of the display screen. These programmable menu items are located in the **Control System Menu**.

To access the Control System Menu:

1. Press and hold the **Home** button for 3 seconds. The display will change to **Setup/Menu**.
2. Touch **Next Item** to navigate to the next menu. Touch **Item Back** to go reverse.
3. Touch **Enter** to enter and change user accessible menu item settings in the control system menus.
4. Most settings are in the USER access level. Other settings will be located in the INSTaller or ADVanced access level depending on the necessity for field adjustment. **See Using the Tool Box Menu for details.**

Control System Menu Descriptions

Menu	Description
SETUP	Displays and modifies the temperature control set points for the burner, integral tank circulator
SOURCE	Displays many factory programmed settings for this product. The settings which can be adjusted by the user will be indicated by the appearance of the up and down adjustment arrows
MONITOR	Displays operational information such as water and vent temperatures, hours of operation, and number of cycles
TIME	Sets the time, day and year. Setting the time clock is necessary when using the scheduled setback
SCHEDULE	Allows the user to create a schedule for reducing the water heater set point when a building is unoccupied for a period of time
NETWORK	Displays and modifies parameters for creating a Modbus communication connection with the water heater. Reset Defaults does not erase the settings in NETWORK.
OVERRIDE	Allows the user to assume manual control of the burner operation and pumps
TOOLBOX	Displays alarm message history. Changes User access level and reset to factory default settings

10.6 Changing The Vent Material Type (ADVanced Level Access)

If the cold inlet water temperature is above 100°F, the use of solid CPVC, Polypropylene or Stainless Steel venting is required and the vent limit switch must be adjusted for the higher temperature rating allowed by these vent materials.

To Change The Vent Type Value

1. From the View Menu, press and hold the HOME button for 3 seconds to enter the Control System Menu. The first menu displayed is the SETUP Menu.
2. Touch the Next Item or Item Back buttons to navigate to the TOOLBOX menu.
3. Touch the ENTER button to display the ACCESS screen.
4. Hold #4 button to change to ADVANCED.
5. Exit the menu by pressing the HOME button.
6. Use the Next Item or Item Back buttons to navigate to the SOURCE menu.
7. Enter the SOURCE menu.
8. Use the Next Item or Item Back buttons to navigate to the VENT TYPE menu.
9. Using the UP or DOWN arrow buttons, select between the four choices: PVC (default setting), PPS, CPVC or SS.
10. Exit the menu by pressing the HOME button.
11. Using NEXT ITEM or ITEM BACK, go to the TOOL BOX menu, press enter. Hold #4 button to remove ADVANCED level, use arrows to return to USER level. Hit HOME to exit TOLL BOX menu, hit HOME button again to exit MENUS.

TURBOPOWER® 96 WATER HEATER

10.7 Changing The Operating Set Point (USER Level Access)

The water TURBOPOWER 96 water heater operates to satisfy the stored water temperature set point of the EOS control. The value of the controls' set point is the desired stored tank water temperature. The unit ships with a factory set point of 120°F.

Although the set point can be displayed in the VIEW menu, it is necessary to enter the Control System Menus in order to make adjustments to the water heater set point and other operational parameters.

To Change the Water Heater Set Point

1. From the **VIEW** Menu, press and hold the **Home** button for 3 seconds.
2. Touch **Next Item** or **Item Back** buttons to navigate to the **SETUP** menu.
3. Touch the **Enter** button then navigate to the **SETPOINT** using the **NEXT ITEM** button.
4. Adjust the set point value using the **UP** and **DOWN** arrow buttons. The new value will be saved when you navigate away using **NEXT ITEM**, **ITEM BACK**, or **HOME** buttons.

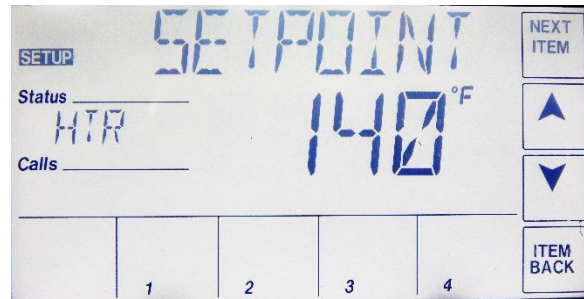
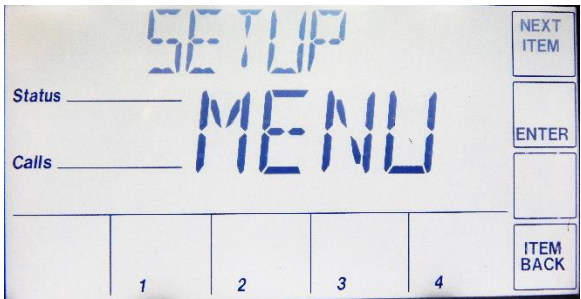

10.8 Setting The Real Time Clock (User & Installer Level Access)

The TIME MENU allows the user to program the time of day, the date and the year. Select 12 or 24 hour time clock as well as daylight saving time can be selected. When selected, the time clock can be displayed in the VIEW MENU.

1. Press and hold the Home button for 3 seconds to enter the Control System Menu. Use the NEXT ITEM button to scroll to the TIME menu. Press the ENTER button to enter the TIME menu.
2. Use the NEXT ITEM button to move to the first screen. Use the UP & DOWN arrow buttons to set the hour, then press the NEXT ITEM button to enter the value and move to the minute. Once the parameters for the time screen have been entered, move to the date and year screen and enter settings in the same manner.
3. Other features that can be configured: display clock in the VIEW MENU, enable daylight saving time, and 12/24 hour clock, use the NEXT ITEM button to move to the correct screen and then the arrow buttons to adjust. Save and exit the menu by pressing the Home button.



TURBOPOWER® 96 WATER HEATER

10.9 Scheduled Setback (USER Level Access)

The SCHEDULE MENU allows the user to program this water heater to automatically lower the operating set point for times when a facility is not occupied or the use of hot water is curtailed.

1. Enter the SCHEDULE MENU. Activate the schedule function by first turning on the HEAT SCHD using the arrow buttons.
2. There are four setback schedule types. 24hr, 5-2, 5-11 and 7DAY. The 24hr schedule is a daily schedule that will follow the same program every day of the week. The default schedule on the SCHED TYPE screen is the 24hr. All other schedule types are selected using the arrow buttons. The 24hr schedule allows for a 2 or a 4 EVENT/DAY. With the 2 event day, the user can have one occupied time and one unoccupied time per day. The 4 event day will allow for two occupied times and two unoccupied times per day.

NOTE: The unoccupied set points are programed in the SETUP MENU in the same manner that the occupied set point is adjusted.

For example, a 24hr type and a 4 event day schedule might look like this:

- The 1st occupied time begins at 6:00am and the 1st unoccupied time begins at 11:00am, therefore, between the hours of 6:00am and 11:00am the occupied set point will be used.
- The 2nd occupied period begins at 4:00pm and the 2nd unoccupied time begins at 10:00pm.
- Between the 1st unoccupied time of 11:00am and the beginning of the 2nd occupied period, the unoccupied set point will be used.
- At 4:00pm the 2nd occupied period will begin and the occupied set point will be used until the 2nd unoccupied period begins at 10:00pm.
- From 10pm until 6:00am, the unoccupied set point will then be used.

Notice that schedule times and set points are identified as occupied (**Occ**) or unoccupied (**UnOcc**) here.

3. The 5-2 schedule type gives the user the ability to program a 2 or 4 EVENT/DAY but will also allow for one schedule to be followed Monday – Friday and then another Saturday and Sunday.
4. The 5-11 schedule type gives the user the ability to program a 2 or 4 EVENT/DAY but will also allow for one schedule to be followed Monday – Friday and then separate schedule Saturday and another Sunday.
5. The 7DAY schedule type gives the user the ability to program a 2 or 4 EVENT/DAY for each day of the week, Monday through Sunday.



TURBOPOWER® 96 WATER HEATER

10.10 Using the Manual Override Menu (INSTaller Level Access)

The OVERRIDE MENU is helpful during the initial commissioning as well as anytime burner adjustment is necessary. Manual override allows control of the burner, integral tank circulator, and the optional SANI pump.

1. Enter the OVERRIDE MENU. Using the arrow buttons, select between the three choices. The default setting is AUTO. In the AUTO position the operating temperature control will work to control the water temperature based on the active set point. When manual control of water heater operation is complete, always return this parameter to the AUTO setting.
2. The second setting is OFF. This setting will stop all control function and prevent the burner from operating.
3. The third setting is HAND. Once enabled, use the NEXT ITEM button for the TIMEOUT setting, this is a safety precaution that will disable the override function at the end of the specified time period if the MAN OVR setting is not returned to AUTO.
4. The next screen is SAN PUMP. To force on the SANI pump, turn this setting to ON. Only used when SANI option present.
5. The next screen is HTR PUMP. To force on the integral tank circulator, turn this setting to ON.
6. The next screen is HTR MOD. This setting will override the operating control and using the up and down arrow buttons, force the burner to fire at the selected firing rate. This function is useful when tuning the operation of the burner at a range of firing rates.

Note: If the HTR MOD control is activated while the burner is firing, the burner will shut down and recycle.

WARNING: When adjustments are complete and before putting the water heater into service, return the MAN OVR function back to “AUTO” Failure to return the MAN OVR function to “AUTO” can cause high water temperatures that can result in property damage, scalding, other serious injury or death.

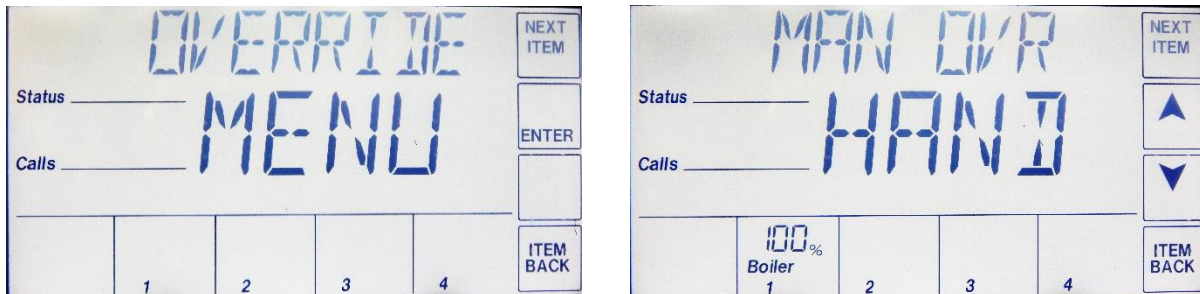

10.11 Potentiometer (Operating Set Point for Standalone Operation)

The PIM Ignition Control will continue to operate the Conquest water heater at a 120 degree internal setpoint should the touch screen control fail, or communication between the two devices is interrupted. This internal setpoint can be adjusted using the potentiometer to maintain a different operating temperature under these circumstances if desired. This feature is intended to be temporary, since accuracy of temperature control and the stored water will be reduced.

IMPORTANT: It is recommended that at the time of commissioning, the startup technician adjusts the potentiometer to the desired temperature set point as displayed in the OPERATOR screen located in the SOURCE control system menu. **NOTE:** If the operating setpoint is ever changed after initial commissioning, the potentiometer should be readjusted as well.

TO ADJUST THE PIM POTENTIOMETER SETPOINT:

1. From the View Menu, press and hold the **HOME** button for 3 seconds to display the SETUP Menu.
2. Using the **NEXT ITEM** or **ITEM BACK** buttons navigate to the **TOOLBOX** menu, then touch the **ENTER** button to display the **ACCESS** menu.
3. Now use the **UP** or **DOWN** arrow buttons to select the **INSTALLER** setting.
4. Touch the **HOME** button to return to the **TOOLBOX** menu, then use the **NEXT ITEM** or **ITEM BACK** buttons to navigate to the **SOURCE** menu.
5. Touch **ENTER** to enter the source menu and use the **NEXT ITEM** or **ITEM BACK** buttons to navigate to the **OPERATOR** screen to display the potentiometer setpoint.



TURBOPOWER® 96 WATER HEATER

6. Open the lower panel of the control enclosure and locate the potentiometer on the PIM Ignition Module.
7. Using a small blade screwdriver, manually adjust the **Potentiometer** to a desired stand-alone setpoint temperature as you view the adjusted temperature setting in the **OPERATOR** screen.
8. Exit the menu by pressing the **HOME** button.

10.12 Using Tool Box Menu

The TOOL BOX MENU contains several adjustable parameters as well as up to the 15 past alarm messages logged.

1. In the Tool Box is the ACCESS level. The three choices available here are USER, INSTaller and ADVanced. USER and INSTaller can be accessed using the arrows. ADVanced level can be selected/toggled by holding the #4 button. Consult factory before changing any settings requiring an ADVanced access level. Depending on the access level selected, different parameters will become visible and adjustable. Selecting the appropriate access level will make menu navigation easier and minimize the possibility that parameters will be unintentionally changed, resulting in improper operation.
2. The SW screen will display the software revision for the touch panel display. Press the enter button to view the suffix.
3. Allows the user to turn the display backlight ON continuously, OFF or TMPY will keep the backlight on only during use.
4. Allows the user to choose between Fahrenheit and Celsius.
5. The last screens will show the 15 most recent alarms. From the first screen. If you hit ITEM BACK, you will see the oldest alarm, item back to move to the next most recent. If the Real Time Clock has been set, the date and time will be logged for each alarm. The alarm history is only available at INSTALLER or ADVANCED user levels. While on the history, hold the CLR button for 3 seconds to clear that error message.

TURBOPOWER® 96 WATER HEATER

11 COMMUNICATIONS AND DIAGNOSTICS

11.1 Indicators

The PIM has three LED indicators to display operational status and to help diagnose system error conditions:

- Power: Green LED indicating the PIM module is receiving 24 VAC power.
- Alarm/Test: Amber LED which indicates the PIM is in Commission Test Mode or that a diagnostic alarm (fault) is present.
- Diagnostic Code: Red LED that is normally off. During a control or system fault condition, this LED flashes the error codes.

11.2 Alarm Messages – Diagnostic Codes (Flashes)

ALARM MESSAGE	DISCRIPTION OF ALARM	LED Flashes	MODBUS CODE #
ID CARD	The ID card is connected to the PIM control board when the system is initialized for the first time, the ID card selects the control profile to be used. An ID card error may occur when the original card is replaced with an incorrect card or has been disconnected from the PIM control board.	Red LED ON, Green LED OFF	20
INTERNAL FAIL	The PIM control board may have failed. Replace the control board if manually resetting the control does not correct the fault.	Red LED ON	21
CTL SETUP FAIL	Try resetting the defaults in the TOOL BOX menu. If unable to correct, replace the control display	N/A	1
VENT LIM	The vent temperature sensor is approaching the programmed limit. This will force the burner to operate at a reduced firing rate to prevent overheating.	N/A	5
AIR FLOW FAIL	During purge and burner operation, the blower speed tachometer is not reaching the minimum blower speed for operations. This could be caused by a faulty blower.	1	9
FLAME FLSE	A false flame signal is usually cause by a leaky gas valve which propagates a flame after the call for heat cycle has ended. Check for leakage through the gas valve. If no mechanical cause can be found, replace flame control.	2	19
FLAME FAIL	Flame failure indicates that during the burner ignition process, the burner either failed to light or it did light but no flame signal was detected. If the burner fails to light it is likely that the hot surface igniter (HSI) is faulty or the burner fuel/air mixture is too far out of adjustment to ignite. If the burner lights but immediately go out, check for an inadequate gas supply, faulty gas valve or regulator or poorly adjusted combustion.	3	15
FLAME LOSS	Flame loss indicates that sometime after flame has been established and the burner is operating, the flame signal is lost. This can be caused by a faulty igniter, damaged refractory or combustion that becomes poorly adjusted as the burner modulates to higher inputs.	3	16
LOW HSI	The PIM control board is not sensing the correct amp draw from the HSI (Hot Surface Igniter). This is most likely caused by a faulty or disconnected igniter.	4	23
LOW 24VAC	The 24VAC supply to the PIM control is below the threshold for reliable control operation. This may be caused by low voltage to the heater or a faulty 120/24VAC supply transformer.	5	24

TURBOPOWER® 96 WATER HEATER

VENT MAX	The vent temperature sensor is used to protect low temperature vent systems from damage caused by high flue gas temperatures. When this alarm occurs, first confirm that the vent material is suitable for the application as well as the limit setting for this control. When this product is operated with high return or inlet water temperature, the flue gas can exceed the rating of low temperature vent systems.	6	17
HTR MAX	The heater high limit temperature safety has exceeded its limit. This condition may be caused by a sensor failure or a faulty control board.	7	18
HTR TOP	Indicates a problem with the top temperature sensor, possibly a broken or shorted sensor wire or failed sensor. Note: The top sensor and the high limit sensor or located in the same probe body.	8	11
HI LIMIT	Indicates a problem with the high limit temperature sensor, possibly a broken or shorted sensor wire or failed sensor. Note: The top sensor and the high limit sensor or located in the same probe body.	8	14
HTR BOT	Indicates a problem with the bottom temperature sensor, possibly a broken or shorted sensor wire or failed sensor.	8	12
VENT	Indicates a problem with the vent temperature sensor, possibly a broken or shorted sensor wire or failed sensor.	8	13
LOGASPRES FAIL	The low gas pressure safety switch (optional) is not sensing the minimum gas pressure required for safe burner operation. Check the gas pressure to ensure that the minimum is available. If the gas pressure is adequate check for fluctuating gas pressure or a faulty pressure switch.	9	10
REM PROV FAIL	The remote proving circuit, when used, is designed to check for the operation of ancillary mechanical room equipment such as a fresh air damper or flow switch. Check for the proper function and correct wiring of such equipment.	10	8
LOW WATER FAIL	The electronic low water cutoff is no longer sensing water at its probe. This could also be cause by a faulty low water board or sensor	12	7
HTR LOST	This could be caused by a poor connection between the PIM control and the digital control display or failure of either device.	14	6
HIGASPRES	Check the gas pressure to ensure that the building supply doesn't exceed the value on the heater rating plate. If the gas pressure is within rated limit, check for a faulty pressure switch.	15	26

11.3 Replacing The Fuse

The 24 VAC input and output circuits of the PIM are protected by a 8.0 Amp fuse.

11.4 Self-Check/Control Failure

The PIM confirms the integrity of the gas valve relay contacts to insure safety. It also monitors the processor memory and software execution for proper program flow. If the control detects an error in its software or hardware, all outputs are turned off and the LED displays a steady ON condition. If this condition persists after an attempt to restart then the control must be replaced.

11.5 System Safety Checks

The PIM monitors the safety switches, temperature sensors, supply voltage, and blower speed and will go to soft lockout until the error condition is corrected. Individual LED diagnostic codes or messages on the RS485 communications help identify the problem for efficient troubleshooting.

TURBOPOWER® 96 WATER HEATER

11.6 Flame Current Measurements

The PIM supports direct measurement of flame signal strength using the flame current test pins (FC+, FC-) on connector P2. Flame current may be measured by a micro amp meter (μA meter), or alternately by using a standard digital voltmeter. The signal on P2 is calibrated to 1 micro-amp/volt, so flame current in micro-amperes can be directly read on the volts scale.

The control display user interface is capable of displaying an approximation of flame current up to 5 micro-amperes.

11.7 Non-Volatile Lockout/Manual Reset

The PIM normally allows for volatile ignition lockout where a lockout condition is reset by a loss in 24VAC power or the call for heat demand. In certain applications or where required by standards (such as CSD-1), it can be configured through the parameter settings for non-volatile lockout after ignition failure. In this case the lockout may only be reset by the on-board manual reset button, or the remote reset on the front panel.

11.8 ID Card

The PIM determines its operating parameters by reading the identification code of an external plug-in ID card. The ID card is connected to the PIM at the J6 connector.

Note: This ID card must be present for the PIM and appliance to operate. This card selects the proper settings in the PIM's memory for various appliance models. The first time a PIM is powered up attached to an ID card, the ID card setting is stored in non-volatile memory. Once set, the PIM only operates with the correct ID card installed that matches its internal ID settings. The PIM verifies the ID card at power-up and on each heating cycle.

12. NETWORK MENU

The Network Menu contains all of the settings necessary to configure a 2-wire, RS-485 communication link with this product. With no additional hardware, a Modbus RTU or BACNET MSTP protocol can be established. For a complete Interface Guide and Points List (PV7213) go to www.pvi.com and look in the documentation and tools page under the Accessories and Controls tab.

13 REMOTE CONNECTIONS – TERMINAL STRIP

13.1 Making BMS/BAS remote connections for analog and binary (on/off) signals

A terminal strip for the remote connection is located behind the bottom control panel door and is accessed removing the two thumb screws and lifting the hinged door.

IMPORTANT: Do not use single strand bell wire for remote field connections to terminals R1-R2 and C1-C2. Use only multi-strand copper wire. See table below for wire length and gauge:

Wire Gauge	18 GA	16GA	14 GA	12 GA
Maximum Length	30 FT	50 FT	75 FT	100 FT

WARNING: Turn off all electrical service to the appliance when accessing the remote connections and close and fasten the control cabinet cover before restoring electrical service to the appliance. The remote connection terminals are High Voltage or may become High Voltage. If the electrical service is not turned off and these terminals are touched, a dangerous shock could occur, causing personal injury or death.

Coupez l'alimentation avant intervention sur l'appareil.

TURBOPOWER® 96 WATER HEATER

13.2 Terminal Functions - The following describes the functions of each of these terminals and the proper method for interfacing with an Energy Management System:

L1-L2: Used for incoming 120VAC power supply connection.

Terminal **L1** is the hot terminal (Black) and **L2** is neutral (White). See the product label or specification document for circuit ampacity rating.

R1-R2: Used to activate / de-activate water heater from remote master control. Terminals are wired to a relay in a remote Energy Management System. When the relay closes, the circuit from R1 to R2 is completed and appliance controls are enabled. This appliance ships from factory with a jumper between terminals Remove jumper when connecting to a remote controller.

A1-A2: Used to activate a remote alarm, signaling shutdown of combustion control. Alarm or Alert, this will be made up on hard lockout and non-hard-lockout conditions until the condition is gone, example; remote proving not made up.

Provides a maximum 2 amp relay 0-30VAC contact closure when the control system terminates operation due to a tripped safety interlock (i.e.: air proving switch, high limit switch or flame sensor, etc.).

P1-P2: Provides a 5 amp 120/240VAC contact closure to control remote equipment (i.e. mechanical room air louvers, draft inducer or power vent, etc.). Do not directly energize additional pumps or motors through these terminals. If operation of remote equipment is required for safe operation of the appliance, the remote equipment must send a return proving signal to terminals C1-C2, via its proving switch, confirming proper operation to enable the appliance to start heating.

C1-C2: Used for proving operation of remote device. Terminals are wired to a proving switch on a remote device such as a power venter, louvers or a combination of these in series. When all remote proving switches close, the circuit from C1 to C2 is completed and the appliance controls are enabled. This appliance ships from the factory with jumper between terminals C1 and C2 that must be removed when a proving switch is connected.

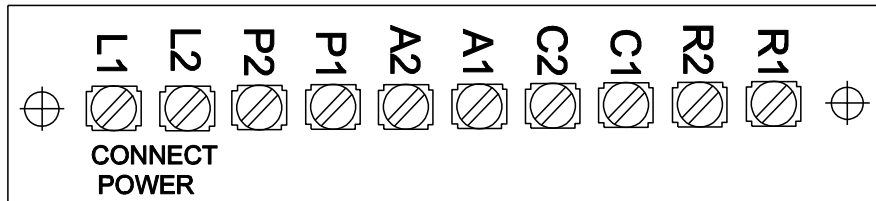

TURBOPOWER® 96 WATER HEATER

14 SEQUENCE OF OPERATION

1. Incoming 120VAC

- a. Full time power to the Main Control Switch

2. Power On - When the main control switch is turned on:

- a. 120V to PIM J13 for blower circuit.
- b. 120V to the fuse.
- c. Fused 120V is applied to the step-down transformer (24V)
- d. Fused 120V is applied to the Electronic Low Water Cut-Off (ELWCO) terminal L1
- e. 24V and Fused 120V is applied to the Platform Ignition Module (PIM). The circulator and HSI circuits are 120V.
- f. The PIM performs a processor and memory self-test to insure proper operation. The PIM confirms the presence of a valid ID card which matches the configuration previously stored in memory. If the valid ID card is not present, the PIM generates a diagnostic fault. The non-volatile memory is checked for an active hard lockout condition. A lockout indicates the previous attempt to light was unsuccessful, such as a hi-limit or other system fault occurred. The PIM stays in hard lockout until a manual reset is performed.

3. Control Device Pre-check – The following control circuits are checked for closer before the control system will initiate a Call for Heat.

- a. The PIM continuously monitors the flame status to verify no flame is present during Standby. If an erroneous flame is detected, the PIM generates a false flame fault.
- b. The Electronic Low Water Cut-Off control is a self-contained electronic device which senses the presence of water at the top of the storage tank. When the presence of water is confirmed, the contacts close on the ELWCO and is sensed by PIM control. A solid red LED on the the LWCO PCB indicates presence of water.
- c. The High Temperature Limit is combined in a common probe body with the upper tank sensor. The PIM will compare the high limit thermistor temperature with the upper tank thermistor temperature. If the two temperatures are not the same, a sensor failure will result.
- d. When the High Temperature Limit operation has been verified by comparison, the limit temperature will then be confirmed to be under the maximum allowable temperature.
- e. The enable circuit between Terminals R1 – R2 must be closed for the heater to start operation, if no external enable, the terminals should be jumped. (Factory default)

4. Call For Heat - If the operating control senses that the temperature at the lower tank sensor is below the heater set point less heater differential and the previous control interlocks and safeties are satisfied, the following sequence will begin:

- a. Terminals P1-P2 are closed to activate any connected remote devices
- b. The circuit between Terminals C1-C2 is closed by any connected remote proving switches, enabling the water heater to continue the sequence of operation.
- c. Gas pressure switches are latching, if proper gas pressures, the contacts will be made up. If the gas switches are tripped, then they will rewire manual reset when proper gas pressure is present.
- d. When the burner blower is energized and the blower speed tachometer senses the minimum rotational speed, operation of the blower will be confirmed.
- e. When the burner blower is energized and air pressure is generated, the Airflow-Proving Switch is verified to close within 60 seconds to prove flow.
- f. The ignition pre-purge delay takes place. Approximately 15 seconds.
- g. The voltage level of the 24 VAC supply input is confirmed to be above 18.0 VAC.
- h. The Ignition cycle begins.

TURBOPOWER® 96 WATER HEATER

5. **Heat-Up** - Following the pre-purge delay, the hot surface igniter will be energized:
 - a. The flame control will send 120V to the hot surface igniter for approximately 20 seconds dwell time.
 - b. The HSI Element proving current is verified.
 - c. The heat-up delay takes place to allow the hot surface element to reach ignition temperature.
6. **Ignition** - When the HSI Element reaches ignition temperature a 4-second Trial for Ignition (TFI) period is initiated:
 - a. The Gas Safety Valves are energized. (Opened) allowing gas to flow.
 - b. The hot surface element is de-energized during the last second of the TFI period.
 - c. During TFI the flame safeguard control will monitor the flame using flame rectification through the hot surface igniter and flame rod on some models..
 - d. If the flame control senses the presence of flame before the end of the TFI period, the flame control will continue to monitor the flame, through the igniter and flame rod, until the operating thermostat ends the call for heat condition.
7. **Heating**
 - a. The flame status, blower speed tachometer, LWCO switch, and other safety switches are continually monitored for proper state.
 - b. The High Limit sensor is confirmed to read below the High Limit setpoint.
 - c. The temperature of water in the tank is compared to the temperature control set point to determine when to begin firing in heating mode.
 - d. The water heater remains in heating mode and, with extended operation, condensation begins to fill the condensation trap and drain line. (a normally operating booster heater does not create condensation). The water heater stops firing when the tank water temperature matches the temperature control set point.
 - e. The gas valve(s) are immediately disabled.
 - f. A Blower Post-purge is completed and the control proceeds to Standby mode.
8. **Integral Circulating Pump** – The circulating pump is controlled dependent on call-for-heat.
 - a. When the main control switch is turned on, the control system will continuously monitor the water temperature in the tank and attempt to maintain a uniform water temperature within the tank by using the integral circulating pump.
 - b. Default settings, when the temperature sensed in the tank drops 5 degrees or more below the temperature setpoint, the pump is energized and a pump circulator icon will illuminate on the control display touch screen.
 - c. The operation of the integral circulating pump may occur during call-for-heat period.
 - d. Setpoint of the pump is by default dependent (DIP) on the heaters setpoint, but the control can be configured for specific setpoint for the pump. PUMP SETPOINT parameter.
9. **Flame Failure / Flame Loss**
 - a. If the igniter fails to sense flame during an attempt to light the burner (Ignition Trail Fail), the ignition control will end the ignition sequence and the gas valve will be closed. Immediately following the end of the first failed ignition cycle, a new ignition sequence will be initiated to attempt to relight the burner. The standard configuration of the TURBOPOWER 96 water heater allows for three ignition failures before lockout. This ignition failure will result in a lockout and require manual reset to attempt operation again
 - b. If the burner successfully lights and operates but the flame is lost, the gas valve will be closed and the blower will continue to operate in order to purge any remaining combustion products from the water heater. The standard configuration of the TURBOPOWER 96 water heater allows for three (Main Flame Loss) occurrences before lockout. Following each (Main Flame Loss) the PIM will purge and initiate the ignition sequence. If the TURBOPOWER 96 water heater fails to light in the following 2 attempts, the error will be logged as a Main Flame Loss.

TURBOPOWER® 96 WATER HEATER

15 INITIAL STARTUP

15.1 Initial Startup Requirements

Installation must be complete prior to performing initial startup; and the startup must be complete prior to placing the water heater into service. Starting the water heater without proper piping, combustion air, venting or electrical connections or control settings can be dangerous and may void the product warranty. The following startup instructions must be followed precisely in order to achieve proper and efficient operation to assure trouble-free service life.

WARNING: Proper startup must be made by a qualified installer or service agency, who must read and follow the supplied instructions and appliance markings. Failure to complete proper startup before use, tampering with controls or not following all instructions and markings may damage this equipment, void the warranty and may result in property damage, personal injury or death.

15.2 Tools and Instrumentation Required

- Electronic Combustion Analyzer with stack temperature and draft gauge
- Two digital or U-tube Manometers or pressure gauges
- Multi Meter VAC, VDC, Ohms, Continuity
- Amp Meter Clamp on recommended
- Normal Hand Tools

15.3 Resources

- Product Installation & Maintenance Manuals
- Start-up Report with instructions
- Local, State, & Federal Codes
- Website: www.pvi.com
- Technical Support: 1-800-433-5654

15.4 On Site Considerations

- Electrical Supply in accordance with the Nameplate Rating
- Adequate uncontaminated indoor or outdoor combustion air
- Adequate Fuel Supply
- Adequate Water Supply
- Exhaust Vent that complies with the installation instructions
- Condensate drainage that complies with the installation instructions
- Enough heat rejection (usage) allow heater to run long enough to complete combustion analysis

15.5 Startup Procedure

1. Carefully study the burner start-up information included in this manual.
2. Fill system tank with water.
 - a. Close the drain valve.
 - b. Open a nearby hot water faucet(s) to allow trapped air to escape when filling the storage tank. Using the T&P valve alone will not allow the tank to completely fill.
 - c. Fully open the shutoff valves on the cold water inlet and hot water outlet piping to the unit.
 - d. A steady flow of water from the hot water faucet(s) indicates that the tank is full. Close the hot water faucet(s).
 - e. Ensure the relief valve is closed.
3. Be sure all connections into the tank are tight, as leaks at tank fittings will damage the insulation.

CAUTION: Be sure the tank is filled with water. Dry firing can cause unwarranted damage to the appliance.

4. **CAUTION:** Conduct the following gas train leakage test before start-up, at annual intervals and prior to investigating the cause of any reported occurrences of delayed ignition.

TURBOPOWER® 96 WATER HEATER

- a. Using an appropriate bubble detection solution, thoroughly coat all gas train pipe connections. If any bubbles are detected, the leaking connection must be tightened, recoated, and rechecked to assure stoppage of the leak.
 - b. Attach a manometer to measure the gas pressure at the manual gas shutoff valve located just upstream of the gas train. Adjust gas train inlet pressure to the specified value (e.g. 10.5" W.C.), and tightly close the gas train manual shutoff valve closest to the burner.
 - c. Reattach the manometer to the gas train manual shutoff valve at the burner and record the measured gas pressure in inches of water column (W.C.). Measure gas pressure again after 15 minutes. If gas pressure has increased 0.5" W.C. or more, the gas leak must be isolated to one or more of the operating gas valves. (For example, a solenoid actuated gas shutoff valve.) After any leaking valve is replaced, the reassembled gas train must be leak tested again before start-up is attempted.
5. Open the hinged, top enclosure panel cover on the appliance to expose control circuit. A wiring diagram is attached to the back of this panel.
 6. Visually check that all components are intact and no damage has occurred during transit.
 7. Check all connections within the control cabinet. A loose connection could cause intermittent shutdowns.
 8. The burner uses a hot surface igniter (HSI) as the ignition source. The gas control system may use a single gas pressure regulator and valves, valve regulator combinations or multiple gas trains.
 9. Connect a test meter to the ignition control to read the flame current in microamps.
NOTE: Flame current may be measured by a micro-ammeter, or alternately by using a standard digital voltmeter. The signal on P2 is calibrated to 1 micro-amp/volt, so flame current in micro-amperes can be directly read on the volts scale.
 10. Check the inlet gas pressure before start-up, using a manometer or a 0 to 28" W.C. pressure gauge for inlet gas pressure. (This is the pressure measured before all components in the gas train.) This manometer must stay connected throughout the testing, as the inlet pressure must be monitored during the firing of the burner. Record static pressure; it must not exceed 10.5" W.C. Pressures above this could cause damage to the diaphragm in the gas valve or pressure regulator. The inlet gas pressure must not fall below 3.5" W.C.
See Gas Train Illustrations for details.
 11. Connect a second manometer to the manifold test port at the shutoff valve closest to the burner.
 12. **Turn-off main gas shutoff valve.**
 13. **Disable or jumper out any BMS/BAS control interface to allow independent setup and adjustment of each water heater.**
 14. Turn unit on using the rocker switch on the front of the control enclosure. When the burner fails to light, the flame control will lockout.
 15. **Turn-on main gas shutoff valve.**
 16. The Call-for-Heat sequence should initiate and display on the touch screen.
 17. If nothing happens, an error or failure message will display indicating that a control interlock or safety control did not satisfy. Some safety devices such as the Low Water Cut-off, Gas Pressure Switches and the High Temperature limit will require manual reset after lockout and therefore can be easily identified.
 18. When the blower motor starts, the Flame Ignition Control will not be energized until positive air flow is established and the Remote Proving Interlock, when used, has closed. If the Flame Ignition Control does not energize, see the troubleshooting guide for help.
 19. After the pre-purge, the flame control energizes the HSI for the heat up period, approximately 20 seconds. At the end of that period the gas valve is opened for approximately 4 seconds. After the burner lights and the primary safety control senses a flame, the burner will remain on until the call for heat is satisfied or operation is interrupted by a safety device.

TURBOPOWER® 96 WATER HEATER

20. If the burner fails to light, the flame control will recycle two more times before lockout unless the TURBOPOWER 96 contains the CSD-1 option. There is only a single try for ignition with the CSD-1 option. When lockout occurs, cycle the main power switch to reset the flame ignition control before the alarm-on-any-failure occurs. When the burner fails to ignite, the most common cause at startup is air in the gas supply. This can usually be corrected with multiple cycles or bleeding the line manually. If the burner lights but blows out, ensure that the burner firing rate is locked in low fire and check for improper combustion or weak flame signal as a possible cause.

21. Burner Combustion Adjustment

Burner combustion must only be adjusted using a combustion analyzer. Do not attempt to adjust burner by sound or sight.

1. With the burner firing, insert the combustion analyzer probe in the flue vent approximately two feet from the appliance.
2. Slightly loosen the set screw at the top of the gas valve shutter flange next to the slotted Valve Orifice Adjustment screw. Gradually turn the valve orifice adjustment screw counter-clockwise to increase gas flow or clockwise to decrease flow to optimize combustion. The desired CO₂ in the combustion products must be between 8.5 and 9.5% for natural gas and between 9.5 to 10.5% for LP gas.

Important: Remember to re-tighten the set screw after valve adjustments are complete.

3. Do not attempt to adjust combustion based on manifold pressure alone. Manifold pressure should only be used as a reference point. It should not be necessary to adjust the regulator for this model. **See Gas Train Illustration below and page 48 for details.**

WARNING: Do not continue to operate the appliance with carbon monoxide levels above 200 ppm. Carbon monoxide is a colorless, odorless and poisonous gas that commonly results from gas combustion. High concentrations of Carbon Monoxide are extremely dangerous to humans and animals. Operation of an appliance at carbon monoxide levels above 200ppm can cause unsafe operation and the potential for poisonous carbon monoxide to enter occupied areas. Such improper installation can cause property damage, personal injury, exposure to hazardous materials or death.

22. Enable or reconnect any BMS/BAS control interface removed prior to the setup and adjustment of each water heater.

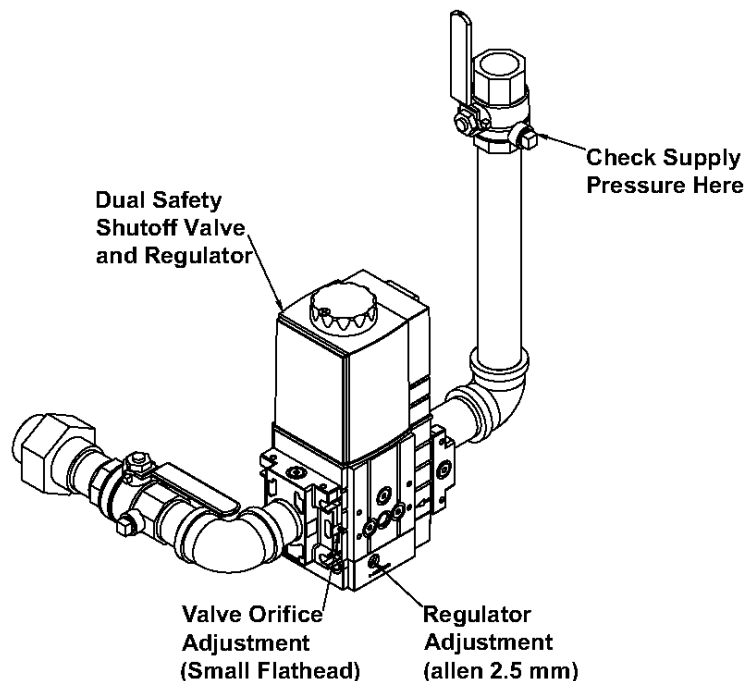

Gas Train Illustration
(Optional components may not be shown)

TURBOPOWER® 96 WATER HEATER

16 POTENTIOMETER (Adjusting the Setpoint)

The PIM Ignition Control will continue to operate the Conquest water heater at a 120 degree internal factory setpoint should the touch screen control fail, or communication between the two devices is interrupted. This internal setpoint can be adjusted using the potentiometer to maintain a different operating temperature under these circumstances if desired. Operator is factory set to 120F. If the PIM module is replaced, the OPERATOR will need to be adjusted.

To Adjust The PIM Potentiometer Setpoint:

9. From the View Menu, press and hold the **HOME** button for 3 seconds to display the SETUP Menu.
10. Using the **NEXT ITEM** or **ITEM BACK** buttons navigate to the **TOOLBOX** menu, then touch the **ENTER** button to display the **ACCESS** menu.
11. Now use the **UP** or **DOWN** arrow buttons to select the **INSTALLER** setting.
12. Touch the **HOME** button to return to the menu selection, then use the **NEXT ITEM** or **ITEM BACK** buttons to navigate to the **SOURCE** menu.
13. Touch **ENTER** to enter the **SOURCE** menu and use the **NEXT ITEM** or **ITEM BACK** buttons to navigate to the **OPERATOR** screen to display the potentiometer setpoint.
14. Open the hinged upper panel of the control enclosure and locate the potentiometer on the PIM Ignition Module.
15. Using a small blade screwdriver, manually adjust the PIM Potentiometer to a desired stand-alone setpoint temperature as you view the adjusted temperature setting in the **OPERATOR** screen.
16. Exit the menu by pressing the **HOME** button twice.
17. The **OPERATOR** screen will time out and you will need to navigate back to it. To help prevent this, while on the operator screen, hit **NEXT ITEM** and then **ITEM BACK** every couple of minutes to prevent the timeout while you are making adjustments.

17 TROUBLESHOOTING PROCEDURE

Before troubleshooting the system, check the following items:

- Verify all mechanical and electrical connections are secure and tight.
- Verify all system wiring is correct.
- Verify there is a proper system ground. The igniter, flame sensor, and ignition module must share a common ground with the burner. *Nuisance shutdowns are often caused by a poor or erratic ground.*
- Follow the “Initial Startup” instructions in section 15 as the first step in any troubleshooting.
- Verify that the system is powered and that the EOS control is calling for heat.
- If the PIM module has an error code (blinking red LED), troubleshoot per **Section 11.2 Alarm Messages – Diagnostic Codes**.

The LED will flash on for 1/10 second, then off for 2/5 second during a fault condition. The pause between fault codes is 8 seconds.

If the problem is not addressed in this chapter or, if after performing the suggested actions, the problem persists, contact the manufacturer of the heating appliance for support.

TURBOPOWER® 96 WATER HEATER

17.1 General Troubleshooting

Symptom	Probable Cause	Corrective Action	
Starting or Pre-purge Failure	Power Supply	Check fuse and/or circuit breaker.	
	On-Off Switch	Check if On-Off switch is illuminated when on. If not check panel fuse or incoming power.	
	Temperature Control	Check that the operating temperature control is set higher than the temperature of the water heater.	
	Remote enable/disable open	Enable water heater or place jumper between terminals R1-R2.	
	Electronic Low Water Cut-off (Red LED is off or blinking)	Check internal ELWCO board. Red LED not lit or blinking indicates a failure. Manual reset is required.	
	Gas Pressure Switches (when installed)	Gas pressure switches are attached to the gas train. Check for a tripped condition indicated by the manual reset button on the switch. Correct low gas pressure condition at the supply.	
	High Temperature Limiting Device	The high limit device is set at 200°F. This device is located at the control flange on the top head of the tank. A high temperature condition may be caused by a failure of the Temperature Control sensors or the circulation pump. This failure requires manual reset.	
	Combustion Air blower		Check if fan control relay is closed.
			Blower motor may have failed.
	Blower Speed Tachometer (if blower is functioning)		Check for loose wires between blower and control.
			Check blower speed measurement with Hz meter. Consult factory.
Remote Proving Interlock		When terminal C1 and C2 are used a proving circuit for remote equipment, failure to close this circuit within the allotted time for Call-for-Heat will prevent operation and cause an alarm indication. Check for proper operation and proving of remote equipment. The flow switch is located in this circuit. No flow will give a proving fault.	
Loose Wire Connections		Check connections to all components.	
Flame Failure	Power Supply	120 VAC is required for operation. Low voltage can cause failure. Voltage below 110 VAC must be investigated.	
	Hot Surface Igniter	Check resistance at room temperature and then the amperage draw during heat-up. Replace if the measured amperage is not within 3.5 to 5.0 Amps or if measured resistance is not within 40-100 ohms (at room temperature). Also, check for overheating condition due to damaged refractory around igniter.	
	Blower Speed Proving	EOS fault code will identify blower speed error. May be faulty blower.	
	Gas Pressure	Check for proper inlet static and dynamic gas pressure, 3.5" WC minimum.	
	Combustion	Inadequate flame signal may result from improper combustion. Adjust to proper CO2 levels. Inability to achieve proper CO2 levels may be caused by a defective gas valve, a defective regulator or blockage in the in the burner or combustion air supply.	
	Grounding	Check for proper ground from flame control to burner housing.	
	Condensate Accumulation	Check that the condensation path from the heater to the drain is not blocked. For TURBOPOWER 96 applied as a booster heater, verify inlet water general purpose water heater is 140°F or higher.	

TURBOPOWER® 96 WATER HEATER

17.2 LED Error Code Listing

The following table lists the errors detected by the Platform Ignition Module (PIM) control and the associated LED indications.

Error Mode	LED Code	Recommended Troubleshooting
Normal Operation	GREEN ON, RED OFF	
ID Card Fault	Red LED Steady ON, Green Power LED OFF	Check that the proper ID card is securely connected. Perform a power and system reset.
Internal Control Failure	RED Steady ON	Perform a power and system reset. If fault remains, replace the PIM.
Airflow Fault	1 flash	Check blower operation.
False Flame Error	2 flashes	Check for proper gas valve closure. Clean burner and electrodes.
Ignition Lockout Fault	3 flashes	Check the gas supply. See Section 6 more information.
Ignition Proving Current Fault	4 flashes	Check HSI element. Replace with a new element of the proper rating.
Low Voltage Fault	5 flashes	Check the 24 VAC input voltage. The voltage must be above 18.0 VAC
Vent Temperature Fault	6 flashes	Check for a blocked flue. Check the vent sensor and connections.
Hi-Limit Fault	7 flashes	Check for proper water flow. Check hi-limit and outlet sensors.
Sensor Fault	8 flashes	See the digital control display for fault identification. Check sensors and wiring.
Safety #1 Fault	9 flashes	Check gas pressure. Verify proper safety switch operation.
Water Pressure Fault	10 flashes	Check piping for leaks. Check pressure switch and connections.
Blower Speed Fault	11 flashes	Verify tachometer signal and connection on J5.
LWCO Fault	12 flashes	Check LWCO switch and connections. Check the water level.
Hi-Temperature Delta Fault	13 flashes	Check pump operation. Confirm proper water flow across heat exchanger.
Ft-bus Communications Fault	14 flashes	Verify the digital control display is connected and operating. Check the cable between the control display and J1.
Safety #2 Fault	15 flashes	Check gas pressure. Verify proper safety switch operation.

TURBOPOWER® 96 WATER HEATER

18 REPLACEMENT PARTS

18.1 Blower & Burner Assembly (Optional components may not be shown)

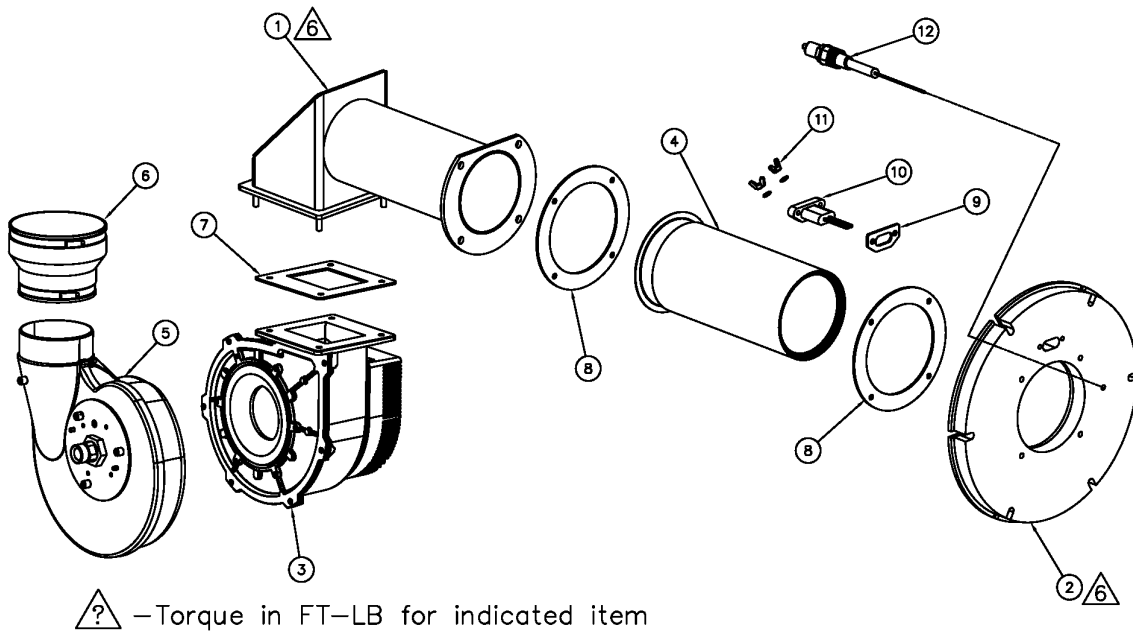

ITEM	DESCRIPTION	MODELS		
		50	75/100	130/160
1	ASSY, TRANSITION BURNER/BLOWER TPX	141207	141248	138370
2	ASSY, BULKHEAD TPX W/INSULATION	128011	128011	128011
3	BLOWER, EBMPAPST #55600.01010 G1G170-AB05-20	126977	-	-
	BLOWER, EBMPAPST #55600.03051 G3G200-GN26-01	-	126337	-
	BLOWER, EBMPAPST #55600.05051 G3G250-GN39-01	-	-	126338
4	BURNER, WORGAS #PRX0195 140 X 310 MM	126852	126852	-
	BURNER, WORGAS #PRX0184 140 X 648 MM	-	-	125559
5	INTAKE, AIR DUNGS WHIRLWIND #257178	126863	-	-
	INTAKE, AIR DUNGS WHIRLWIND #255951	-	126864	-
	INTAKE, AIR DUNGS WHIRLWIND #255678	-	-	126895
6	ADAPTER, FLEXIBLE RUBBER	126850	126849	127733
7	GASKET, BLOWER OUTLET, SILICONE	148665	148666	148667
8	GASKET, FLANGE BURNER 1/8 232 CRANEGLAS 5.750 ID	126509	126509	126509
9	GASKET, IGNITOR 1/8 232 CRANEGLAS Y271	111791	111791	111791
10	IGNITER, HOT SURFACE NORTON #271Y MB478843	107774	107774	107774
11	NUT, HEX 1/4 X 20 NC STEEL ZINC PLT	3475	3475	3475
12	ELECTRODE, FLAME CROWN #26779 WITH 1/2 X 14 GLAND NUT	127816	127816	127816

TURBOPOWER® 96 WATER HEATER

18.2 Control Panel Components

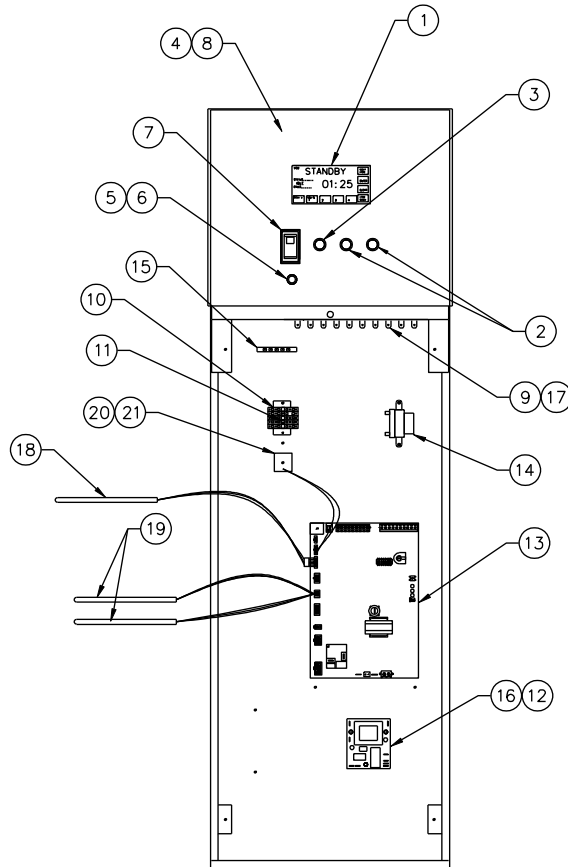

ITEM	DESCRIPTION	MODELS		
		50	75/100	130/160
1	KIT, EOS BTCII USER INTERFACE REPLACEMENT	145259	145259	145259
2	SWITCH, SPST N.C. MOMENTARY CONTACT SELECTA #SS229	70573	70573	70573
3	SWITCH, SPST N.O. MOMENTARY CONTACT SELECTA #SS228	75908	75908	75908
4	FACE PLATE DECAL	141052	141052	141052
5	FUSEHOLDER, PANEL TYPE #HTB-28I	5613	5613	5613
6	FUSE, MDA 15 AMP BUSS 250V	5742	5742	5742
7	SWITCH, CARLING #LTILA51-6S-BL-AM-NBL-125N/INDP AMBER LIGHT	70565	70565	70565
8	PLATE, FACE PIM/Digital Control Display	126076	126076	126076
9	BOARD, TERMINAL ELEC-TRON #PV13080 20 POLE FEED	122346	122346	122346
10	BLOCK, TERMINAL WAGO #280-833 600V 20A DIN	122319	122319	122319
11	JUMPER, TERMINAL BLOCK WAGO #280-402 23A	122320	122320	122320
12	PROBE, LWCO WARRICK #3L1D002.75 W/1/8 MPT 316 SST	58154	58154	58154
13	KIT, PIM CONTROL REPLACEMENT TP96	145261	145261	145261
14	TRANSFORMER, STEP DOWN TRIAD #F5-24 115VAC 24VCT 12.0VA	126865	126865	126865
15	BAR, GROUND SQUARE D #PK5GTA 5 POLE	122321	122321	122321
16	LWCO, PROTODESIGN #LW-3-C-1-A-03 120V	129013	129013	129013
17	BOARD, TERMINAL ELEC-TRON #PV16237 10 POLE FEED THRU TYPE	140328	140328	140328
18	HIGH LIMIT/UPPER THERMISTOR SENSOR #91769 DUAL	126090	126090	126090
19	LOWER OPERATOR/FLUE TEMP THERMISTOR SENSOR #91768 SINGLE	126089	126089	126089
20	CARD, PIM FENWAL #05-900000-010 WATERHEATER	143364	143365	143356
21	CABLE, CARD FENWAL #05-900001-018	126537	126537	126537

TURBOPOWER® 96 WATER HEATER

18.3 Gas Train Assembly

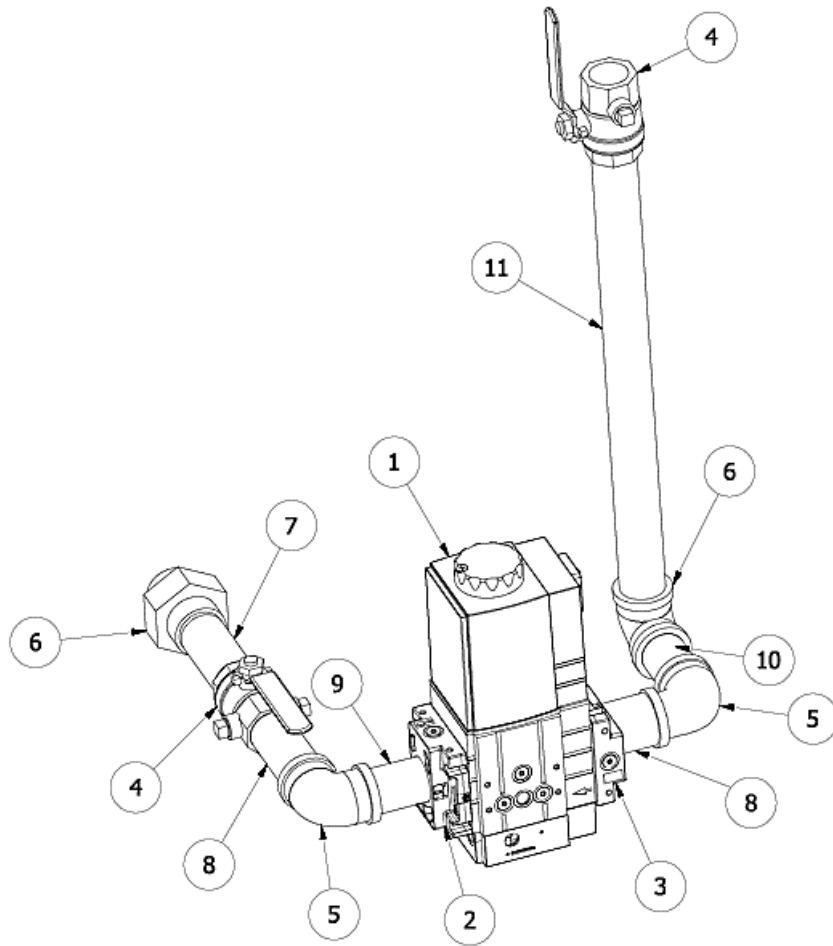

ITEM	DESCRIPTION	MODELS		
		50	75/100	130/160
1	VALVE,GAS DUNGS #259487 MBC SE 1000/602L S02 120VAC	109884	109884	-
	VALVE,GAS DUNGS #262633 MBC SE 2500/602L S02 120VAC	-	-	140263
2	SHUTTER, FLANGE DUNGS MBC	126862	126862	110302
3	FLANGE, VALVE DUNGS	110308	110308	102838
4	VALVE,SHUTOFF GAS RUB	148964	148964	148965
5	ELL, BLACK 90DEG 1 1/2	-	-	6168
	ELL, BLACK 90DEG 1	6163	6163	6187
6	UNION, BLACK 1	5929	5929	5929
7	NIPPLE, BLACK 1 X 4	6014	6014	6014
8	NIPPLE, BLACK 1 X 3	6012	6012	-
	NIPPLE, BLACK 1 1/2 X 2	-	-	6053
9	NIPPLE, BLACK 1 X 2 1/2	61171	61171	-
	NIPPLE, BLACK 1 1/2 X 2 1/2	-	-	6054
10	NIPPLE, BLACK 1 X 3	6012	6012	-
	NIPPLE, BLACK 1 1/2 X 4	-	-	6057
11	NIPPLE, BLACK 1 X 16	9202	9202	-
	NIPPLE, BLACK 1 1/2 X 16			9205

TURBOPOWER® 96 WATER HEATER

18.4 Drain Valve – T & P Relief Valve – Integral Circulating Pump Assembly

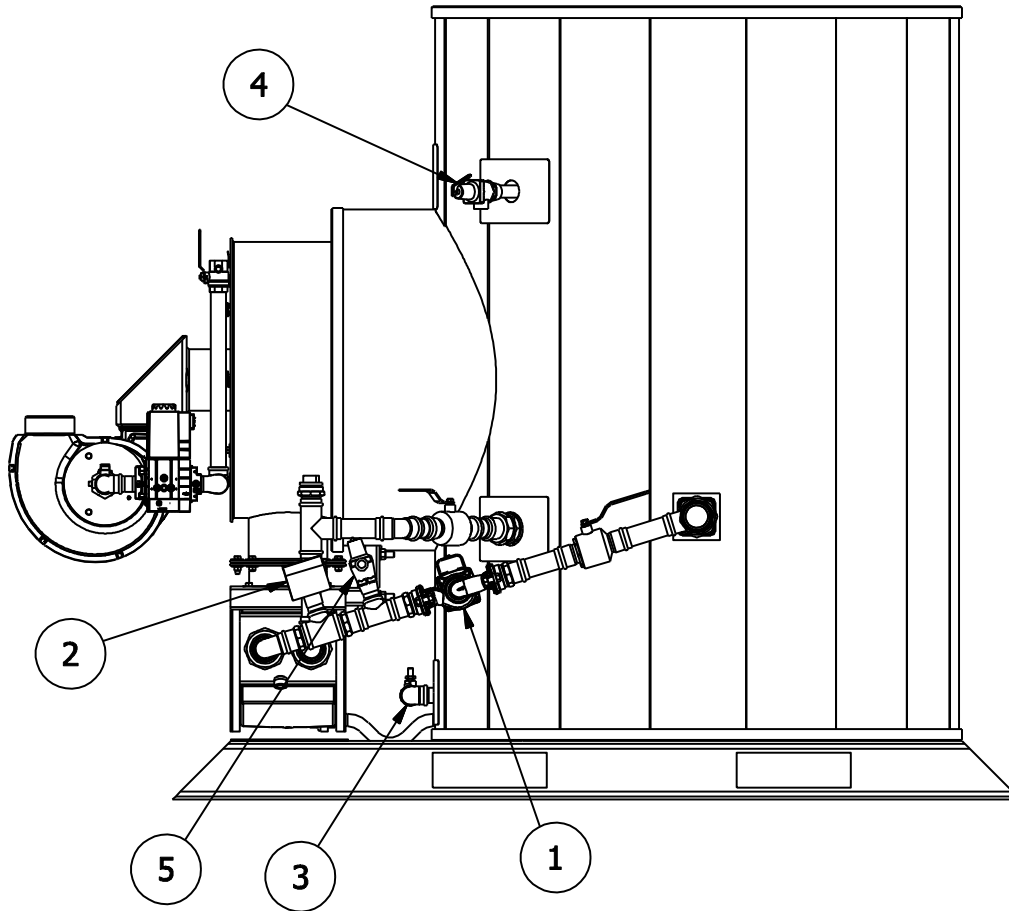

ITEM	DESCRIPTION	MODELS		
		50	75/100	130/160
1	PUMP, CIRCULATING TACO #007-SF5	126117	-	-
	PUMP, CIRCULATING FLANGED TACO #L1121-Y6SI1-FHA1	-	140784	-
	PUMP, CIRCULATING 1/6 HP TACO #2400-30S-3P	-	-	139698
2	SWITCH, FLOW MCDONNELL-MILLER #120611 MODEL #FS251	110986	110986	110986
3	VALVE, BALL WATTS #FBV-3C BRASS THREADED	77085	77085	77085
4	VALVE, T&P RELIEF 1 WATTS #140X-6 150 PSI	709	709 (2)	709 (2/3)
5	VALVE, SAFETY RELIEF 1 X 1 1/4 WATTS #0390704	148744	148744	148744

TURBOPOWER® 96 WATER HEATER

19 PERIODIC MAINTENANCE

Listed below are items that must be checked to ensure reliable operations. Maintenance must be performed by a qualified service or maintenance provider. To ensure proper maintenance, the following instructions should be posted near the appliance and maintained in legible condition. Verify proper operation after servicing.

WARNING: When servicing the controls, use exact, Factory authorized, replacement parts and label all wires prior to disconnection. Verify proper operation after servicing. Incorrect parts substitution and wiring errors can cause damage, improper operation, fire, carbon monoxide, exposure to toxic fumes or other unexpected and unsafe conditions that can result in fire, personal injury or death.

1. Examine the appliance and venting system at least once a year. Check more often in first year to determine inspection interval.
 - a. Check all joints and pipe connections for tightness, corrosion or deterioration.
 - b. Check the electronic-ignition system for quick ignition and a proper flame signal.
 - c. Check all safety controls including thermostats for proper operation.
 - d. Check safety shut-off valves for operation and tightness.
 - e. Keep appliance area clear and free from combustible materials, gasoline and other flammable vapors and liquids.
 - f. Have the entire system, including, but not limited to, the burner, heat exchanger and venting system, periodically inspected by a qualified service agency.
2. Exposure to Dusty or Dirty Combustion Air: An appliance installed in a dust or dirt contaminated atmosphere will require more frequent inspection and cleaning of the burner to prevent nuisance shutdowns or premature burner failure.
3. Any sign of soot on the heat exchanger or in the flue indicates the need for a combustion inspection. Properly installed and adjusted units seldom need heat exchanger cleaning. If soot has formed, the most common causes are restricted combustion air or excessive gas. A blocked heat exchanger can cause unsafe operation and will reduce efficiency. To inspect and clean the heat exchanger, a qualified service agent or installer should use the procedures described in items 4, 5 & 6 below.
4. All gaskets on disassembled components must be replaced on reassembly with exact, Factory Authorized, replacement parts only. Gasket kits are available from your PVI Industries® Representative or by contacting PVI Industries®, LLC.
5. Burner and/or Heat Exchanger Inspection and Cleaning Procedure:
 - a. Turn off main power to unit.
 - b. Turn off gas supply.
 - c. Write notes and/or take pictures during this process to aid in correct reassembly.
 - d. Disconnect components by disconnecting the wires going to terminal strip in the top control enclosure and the respective conduit connections on the back of the control enclosure. If a wiring diagram is not attached to the back of the enclosure door or otherwise provided with the water heater, make careful notes of the locations for all the wires.
 - e. Remove the metal cover on top of the appliance by disconnecting the fasteners holding it to the plastic jacket.
 - f. Remove the hot surface igniter, (HSI) from the burner. Be very careful not to bump the igniter element due to the fragility of the igniter.
 - g. Break the unions that connect the gas train to the blower and the gas supply pipe. Remove the gas train.
 - h. Remove the nuts that secure the burner top plate to the combustion chamber and lift the blower/burner assembly up until it is completely extracted from water heater.
 - i. Inspect top plate refractory for damage. The refractory must provide a tight seal against the top edge of the burner deck.
 - j. Inspect the burner surface for signs of cracking or thermal fatigue.
 - k. If internal inspection of the burner is desired or the burner or blower must be replaced, remove the nuts that attach the blower to the burner top plate to remove the blower. The burner can now be extracted. Be careful not to damage the refractory when removing the burner. With the burner removed, inspect the deck surface of the burner for lent or other blockage carried in the fuel air stream. If blockage has accumulated, use brush to loosen debris and use a vacuum or water to remove it from the burner cavities.

TURBOPOWER® 96 WATER HEATER

- I. Replace any damaged components and reassemble in reverse order. (4-5 ft/lbs).
- m. Cycle unit and test to verify all safety and operating controls are properly functioning and the burner top plate flange is free of leaks.
6. Inspect the integral circulation pump for gasket leaks or failure or the pump motor. Rotation of the pump is indicated by the cooling fan on the back of the motor. See the Troubleshooting Guide or Section 17 for information about operation of the pump.
7. Inspect low water cutoffs and relief valves for proper operation at every six months, or more often if indicated by inspection.
8. Keep appliance area clear and free from combustible materials, gasoline and other flammable vapors and liquids.
9. Check frequently to be sure the flow of combustion and ventilation air is unobstructed to the appliance.
10. When electrical controls are serviced or replaced, label all connections as they are removed, to know the proper placement on the replacement part.
11. All replacement parts are available through your PVI Industries® Dealer. If you need assistance identifying or contacting your local dealer, you may contact PVI Industries, LLC directly at the address and telephone number located on the first and last page of this manual.
12. If the appliance is to be shut down for an extended period of time, the primary gas valve and the water supply should be shut off. When the appliance is returned to service, any standing water in the tank must be flushed and a thorough inspection of all utilities and general appliance condition should be conducted.

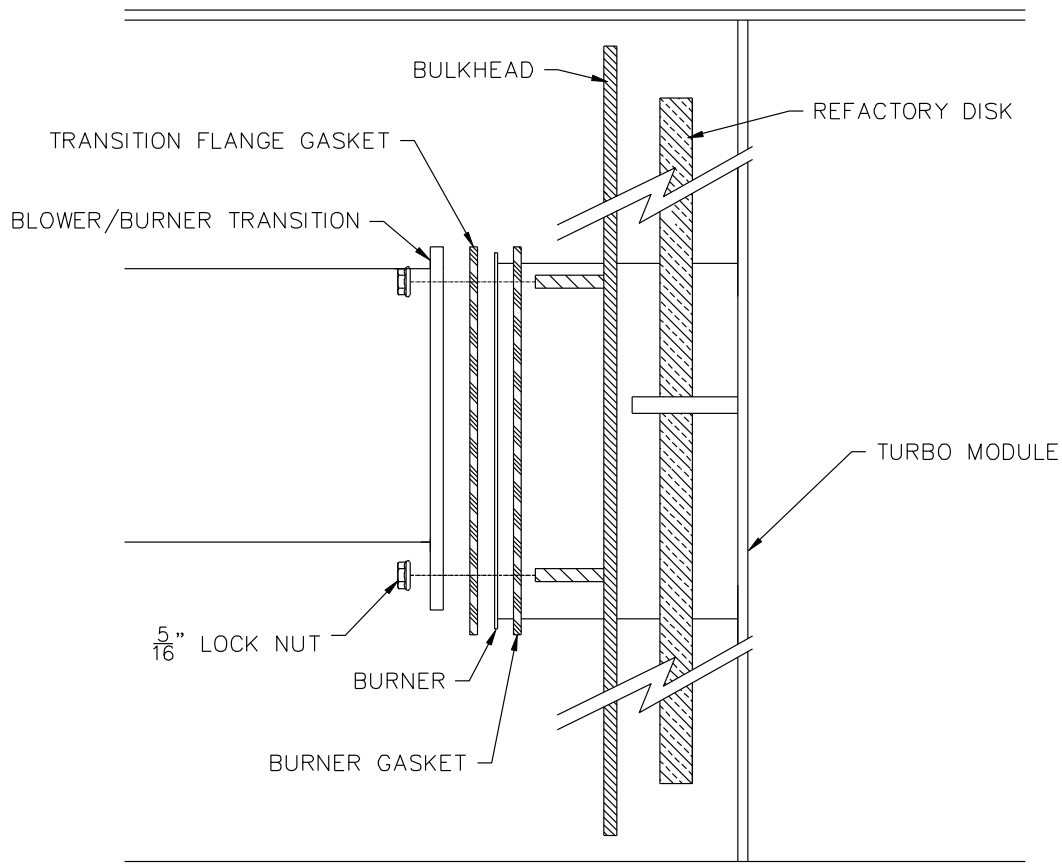

TURBOPOWER® 96 WATER HEATER

20 RECOMMENDED MAINTENANCE SCHEDULE

Regular service by a qualified service agency and routine maintenance must be performed to ensure safe, reliable and efficient operation.

Yearly (Every 12 Months)

Schedule annual service call by qualified service agency.

1. Check for piping leaks around pumps, relief valves, and tank connections. Repair, if found.
2. Check to ensure area is free from combustible materials, gasoline, and other flammable vapors or liquids.
3. Visually inspect venting system for proper function, deterioration or leakage.
4. Check temperature and pressure relief valve. Refer to manufacturer's instructions on valve.
5. Inspect condensate drain and ensure condensate is directed to an appropriate condensate system or drain, as required by local codes.
6. Check all operation of safety devices. Refer to manufacturer's instructions.
7. Inspect burner and gas train components for wear or deterioration.
8. Check the electronic-ignition system for quick ignition and proper flame signal.
9. Check gas safety shut-off valves for proper operation and tightness.
10. Follow startup procedure in the Installation & Maintenance Manual.

Semi-Annually (Every Six Months)

1. Test Low-water-cut-off. Hold LWCO TEST button in for 10 seconds. When a need for heat is present, the heater will lockout. Hold RESET in for 30 seconds to reset the lockout.
2. Test the electronic-ignition flame failure detection system. While heater is heating, shut off gas supply to kill the flame. The heater should shutdown and try to light 3 times hard lockout. Open the gas valve and then hold RESET in for 10 seconds to reset lockout condition.

Monthly

1. Check condensate drain system and refill the condensate neutralizer with limestone (change interval as needed).
2. Visually inspect venting system for proper function, deterioration or leakage.
3. Confirm the low-water cutoff and alarm are operating.

Daily

1. Check for and remove any obstruction to the flow of combustion or ventilation air to the unit.
2. Check to ensure area is free from combustible materials, gasoline, and other flammable vapors or liquids.
3. Check gauges, monitors and indicators.

As Required

1. Open drain to remove any accumulated sediment. Start annually and adjust as local conditions and water quality require.
2. Flush and clean tank as required.

TURBOPOWER® 96 WATER HEATER

21 REQUIREMENTS FOR THE COMMONWEALTH OF MASSACHUSETTS:

This equipment complies with Massachusetts State Fuel Gas and Plumbing Codes CMR 248 3.00-10.00 as amended.

- a) For all side wall horizontally vented gas fueled equipment installed in every dwelling, building or structure used in whole or in part for residential purposes, including those owned or operated by the Commonwealth and where the side wall exhaust vent termination is less than seven (7) feet above finished grade in the area of the venting, including but not limited to decks and porches, the following requirements shall be satisfied:
 1. **INSTALLATION OF CARBON MONOXIDE DETECTORS:** At the time of installation of the side wall horizontal vented gas fueled equipment, the installing plumber or gasfitter shall observe that a hard wired carbon monoxide detector with an alarm and battery back-up is installed on the floor level where the gas equipment is to be installed. In addition, the installing plumber or gasfitter shall observe that a battery operated or hard wired carbon monoxide detector with an alarm is installed on each additional level of the dwelling, building or structure served by the side wall horizontal vented gas fueled equipment. It shall be the responsibility of the property owner to secure the services of qualified licensed professionals for the installation of hard wired carbon monoxide detectors.
 - a. In the event that the side wall horizontally vented gas fueled equipment is installed in a crawl space or an attic, the hard wired carbon monoxide detector with alarm and battery back-up may be installed on the next adjacent floor level.
 - b. In the event that the requirements of this subdivision cannot be met at the time of completion of installation, the owner shall have a period of thirty (30) days to comply with the above requirements; provided, however, that during said thirty (30) day period, a battery operated carbon monoxide detector with an alarm shall be installed.
 2. **APPROVED CARBON MONOXIDE DETECTORS:** Each carbon monoxide detector as required in accordance with the above provisions shall comply with NFPA 720 and be ANSI/UL 2034 listed and IAS certified.
 3. **SIGNAGE:** A metal or plastic identification plate shall be permanently mounted to the exterior of the building at a minimum height of eight (8) feet above grade directly in line with the exhaust vent terminal for the horizontally vented gas fueled heating appliance or equipment. The sign shall read, in print size no less than one-half (1/2) inch in size, "GAS VENT DIRECTLY BELOW. KEEP CLEAR OF ALL OBSTRUCTIONS".
 4. **INSPECTION:** The state or local gas inspector of the side wall horizontally vented gas fueled equipment shall not approve the installation unless, upon inspection, the inspector observes carbon monoxide detectors and signage installed in accordance with the provisions of 248 CMR 5.08(2)(a)1 through 4.
- b) **EXEMPTIONS:** The following equipment is exempt from 248 CMR 5.08(2)(a)1 through 4:
 1. The equipment listed in Chapter 10 entitled "Equipment Not Required To Be Vented" in the most current edition of NFPA 54 as adopted by the Board; and
 2. Product approved side wall horizontally vented gas fueled equipment installed in a room or structure separate from the dwelling, building or structure used in whole or in part for residential purposes.
- c) **MANUFACTURERS REQUIREMENTS – GAS EQUIPMENT VENTING SYSTEM REQUIRED:** When the manufacturer of Product Approved side wall horizontally mounted gas equipment provides a venting system design or venting system components with the equipment, the instructions provided by the manufacturer for the installation of the equipment and the venting shall include:
 1. Detailed instructions for the installation of the venting system or the venting system components: and
 2. A complete parts list for the venting system design or venting system.
- d) **MANUFACTURER REQUIREMENTS – GAS EQUIPMENT VENTING SYSTEM NOT PROVIDED:** When the manufacturer of product approved side wall horizontally vented gas fueled equipment does not provide the parts for the venting of flue gases, but identifies "special venting systems," the following requirements shall be satisfied by the manufacturer:
 1. The referenced "special venting system" instructions shall be included with the appliance or equipment installation instructions; and
 2. The "special venting systems" shall be product approved by the Board, and the instructions for that system shall include a parts list and detailed installation instructions. Detailed installation instructions and parts list are available online for the following venting systems for use on this equipment:

Heat Fab Website – Saf-T-Vent EZ-Seal Installation & Maintenance Instructions <http://www.heatfab.com/products/saf-t-vent/saf-t-vent-ez-seal.asp?xid=x1>

Metal-Fab Website – Metal-Fab CORR/GUARD Installation & Maintenance Instructions http://www.metal-fabcommercial.com/content/products/corr_guard

Selkirk Metalbestos Website – Saf-T-Vent EZ-Seal (same as Heat Fab) Installation & Maintenance Instructions <http://www.selkirkusa.com/products/venting.aspx>
- e) Relief valve must be installed and plumbed in accordance with the authority having jurisdiction. Massachusetts 248 CMR requires relief valve discharge 12 inches off finished floor.
- f) A copy of all installation instructions for all side wall horizontally vented gas fueled equipment, all venting instructions, all parts lists for venting instructions, and/or all venting design instructions shall remain with the appliance or equipment at the completion of the installation.

TURBOPOWER® 96 WATER HEATER

TURBOPOWER® 96 WATER HEATER

Since PVI cannot control the use of the appliance, water conditions, or maintenance, the warranty on the heat exchanger does not cover poor performance, structural failure, or leaking due to an excessive accumulation of scale.

Warranty Forms Ship Separately with Each Product

MODEL NUMBER: _____

SERIAL NUMBER: _____

INSTALLATION DATE: _____