

QuickDraw® STEAM

STORAGE-TYPE HOT WATER GENERATOR

AquaPLEX® STORAGE TANK (UNLINED DUPLEX ALLOY)

TANK SERIES 250 GALLON

MODEL NUMBER	GPH RECOVERY and LB/HR STEAM REQUIRED @ 15 PSI STEAM TO THE INLET *		A COLD INLET AND RETURN NPT	B HOT OUTLET NPT	C STEAM INLET NPT * (@ 15 psi)	D CONDENSATE TRAP CONNECTION NPT **	E PULL SPACE FOR U-TUBE	F CHANNEL SKID LENGTH	F & T TRAP SIZE (@ 15 PSI)	SHIPPING WEIGHT LBS
	40°F to 120°F	40°F to 140°F								

SINGLE-WALL

380 L 250A-QS	520	360	380	330	2	2	1	3/4	33	46	3/4	1040
520 L 250A-QS	700	480	520	450	2	2	1-1/2	3/4	45	46	3/4	1190
900 L 250A-QS	1220	850	900	780	2	2	2	1	45	46	1-1/4	1240
1230 L 250A-QS	1680	1160	1230	1070	2	2	2	1	57	55	1-1/2	1240
1780 L 250A-QS	2420	1680	1780	1540	2	2	2-1/2	1-1/4	45	46	1-1/2	1290
2280 L 250A-QS	3100	2150	2280	1980	2	2	2-1/2	1-1/4	57	55	2	1340
3790 L 250A-QS	4740	3300	3790	3300	2	2	2-1/2	2	57	55	2	1440
	gph	lb/hr	gph	lb/hr								

DOUBLE-WALL

330 L 250A-QSD	440	310	330	280	2	2	1	3/4	33	46	3/4	1040
440 L 250A-QSD	600	410	440	380	2	2	1	3/4	45	46	3/4	1190
830 L 250A-QSD	1120	780	830	720	2	2	1-1/2	1	45	46	1-1/4	1240
1520 L 250A-QSD	2060	1430	1520	1320	2	2	2	1-1/4	45	46	1-1/2	1290
1940 L 250A-QSD	2640	1830	1940	1680	2	2	2-1/2	1-1/4	45	46	1-1/2	1390
2650 L 250A-QSD	3600	2500	2650	2300	2	2	2-1/2	2	45	46	2	1390
3790 L 250A-QSD	4740	3300	3790	3300	2	2	2-1/2	2	45	46	2	1590
	gph	lb/hr	gph	lb/hr								

* For recoveries, steam flows, valves, and trap sizes at different steam pressures and temperature rises, refer to applicable forms on the website.
 ** Dimension shown is for connection at the heat exchanger head. This must be piped to an F&T condensate trap. For sizes, see applicable forms on the website.
Electrical requirements: 120V, 1Ø, 60 Hz., 20 amps maximum, to a single point connection.
 Dimensions are in inches unless otherwise noted. Height to steam inlet and height to condensate connection are approximate dimensions.
 For standard and optional equipment, see form PV 8146.

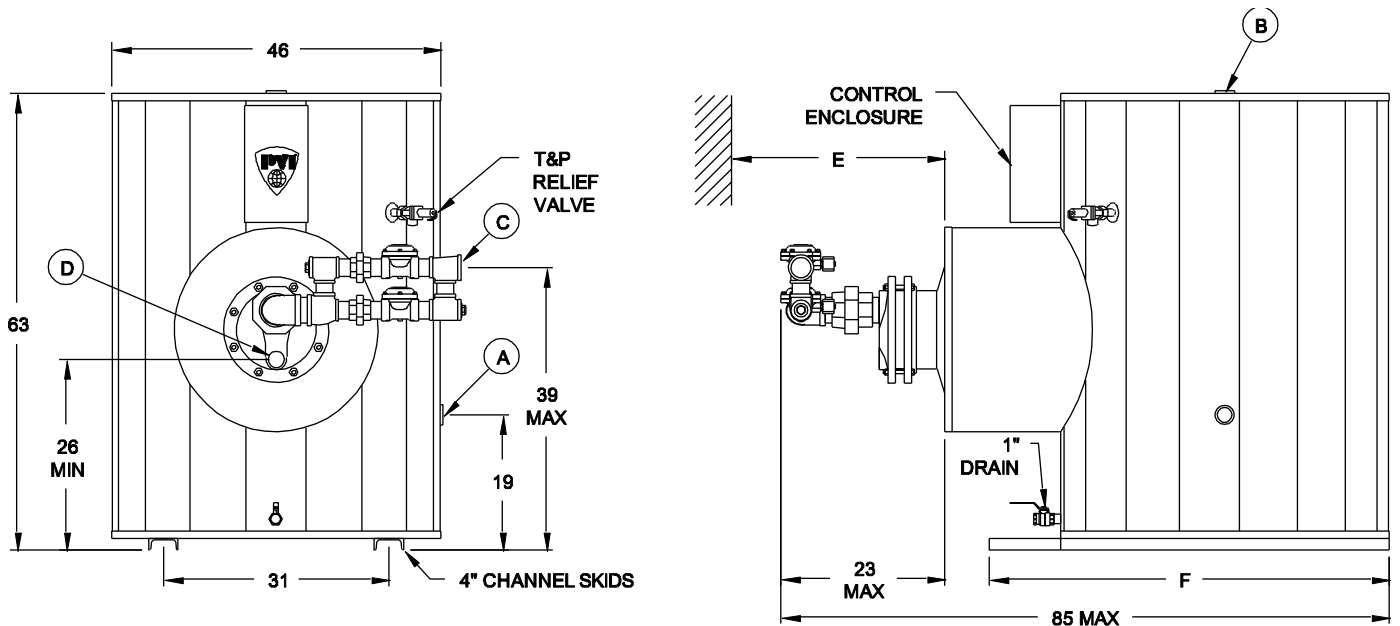

PVI RESERVES THE RIGHT TO CHANGE THE DESIGN AND SPECIFICATION WITHOUT NOTICE.