

GENERAL PIPING GUIDELINE: Two Conquest® or Power VTX® Water Heaters and Two Storage Tanks

Refer to heater and tank Installation manuals for full details.

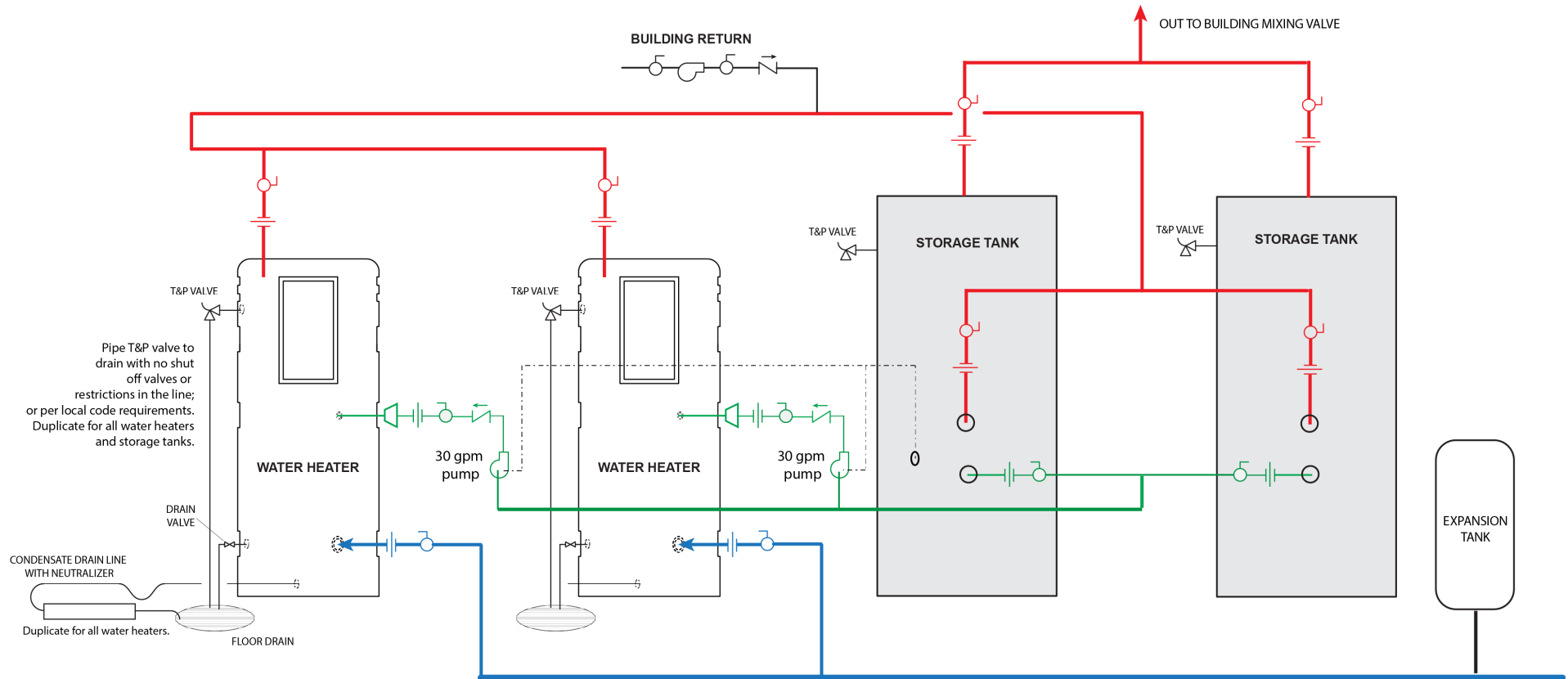

NOTES:

1. Do not exceed 160°F stored water temperature in the sidarm tank.
2. Utilize balanced or reverse return piping between the heaters and the storage tank.
3. Ensure all pipe diameter are sized adequately to handle the flow volume (gpm) at a maximum water velocity of 6 feet per second.
4. **Circulating pumps require separate electrical circuit wired through the tank thermostat.** Tank-mounted thermostat energizes pumps on a call for heat. Heater runs independently on its own set point. Pumps de-energize when tank temperature is restored.
5. Bypass piping allows heater to continue operation with the storage tank removed from the system.
6. During initial startup of the heater and tank, the heater may cycle occasionally.

