

POWER VT® Plus Condensing Water Heater

AquaPLEX® STORAGE TANK (UNLINED DUPLEX ALLOY)

TANK SERIES 250 Gallon ■ 1500 to 2000 MBH

MODEL	BTU INPUT	GPH RECOVERY (thermal efficiency)		SHIPPING WEIGHT (LBS.)	OPERATING WEIGHT (LBS.)
		70° to 140°F ①	40° to 140°F ②		
150 LX 250A-PVIF	1,500,000	2470 (96%)	1737 (96.5%)	2115	3375
180 LX 250A-PVIF	1,800,000	2964 (96%)	2085 (96.5%)	2115	3375
200 LX 250A-PVIF	2,000,000	3293 (96%)	2317 (96.5%)	2115	3375

① Recoveries and thermal efficiency derived from DOE 10 CFR 431 testing requirements (ANSI Z21.10.3 @ 70°F to 140°F).
 ② Recoveries and thermal efficiency based upon 40°F entering water temperature at full fire.
 Dimensions are in inches unless otherwise specified.
 For standard and optional equipment, see form PV 8005.

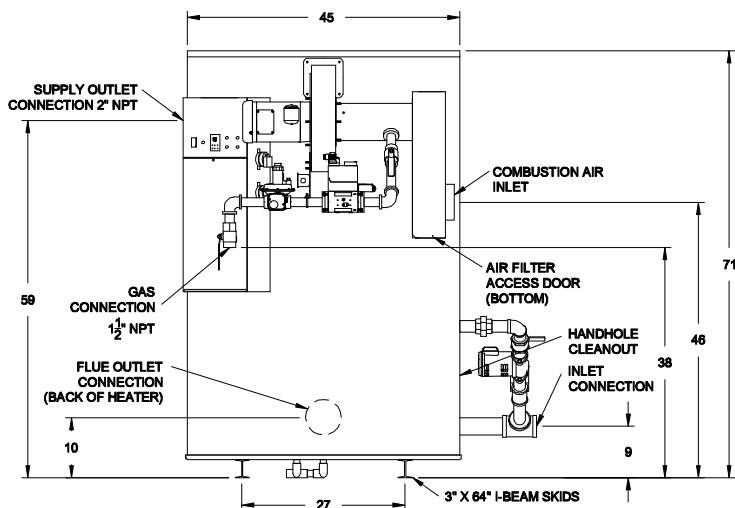
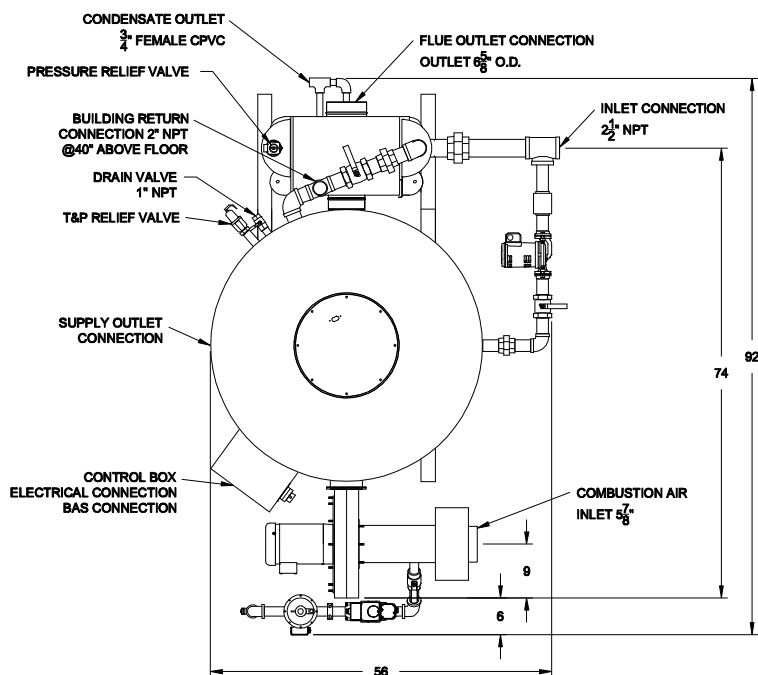

Standard Electrical

120V, 1Ø, 60 Hz., 15 amp circuit

Venting

Use a 6" CPVC vent or use an ETL, UL, ULC or CSA listed single or double wall 6" stainless steel or listed Polypropylene Category IV venting system, minimum distance 5 eq. feet, maximum distance 100 eq. feet. Longer vents, ETL listed with larger diameters, see I&M.

Inlet Combustion Air

Up to 100 eq. ft. using 6" PVC or galvanized vent pipe. Longer lengths, ETL listed with larger diameters, see I&M.

Gas Pressure - Natural

Minimum inlet flow pressure: 4.5" W.C.
 Maximum static pressure: 14" W.C.
 For < 4.5" W.C., consult factory.
 For LP option, consult factory.

Minimum Service Clearances

18" from sides,
 24" from front and top

Emissions

< 20 ppm NOx

During installation, heater must remain upright. Do NOT tilt or lay heater on its side.

PVI RESERVES THE RIGHT TO CHANGE THE DESIGN AND SPECIFICATION WITHOUT NOTICE.