

MAXIM • PACKAGED GAS /OIL WATER HEATER

AquaPLEX® STORAGE TANK (UNLINED DUPLEX ALLOY)

TANK SERIES 125 GALLON

MODEL NUMBER ▶	40-2.8 L 125A-PGO	48-3.4 L 125A-PGO
GPH Recovery at 70° to 140° F	554	665
GPH Recovery at 40° to 140° F	387	465
Input Btu/h	400,000	480,000
Input gph #2 Fuel Oil	2.8	3.4
* Min. Inlet Flow Gas Pressure " W.C.	4.5" W.C.	4.5" W.C.
* Max. Static Gas Pressure " W.C.	14" W.C.	14" W.C.
Motor HP 120 V, 1Ø, 60 Hz.	1/3	1/3
Motor Amps	8	8
Max. Oil gph (gear capacity) Ø	20	20
A Cold Inlet - NPT	2	2
B Hot Outlet - NPT	2	2
C Drain - NPT	1	1
D I - Beam Skids	3 x 34-1/2	3 x 34-1/2
F Overall Height	75	82
G Flue Outlet Diameter	7	8
H Gas Inlet	1	1
J Oil Inlet	1/2	1/2
L Height to Outlet	65	73
M Height to Inlet	28	36
N Depth of Burner Housing	31	31
Approx. Shipping Weight - lbs	1120	1260

Recoveries based on 80.5% thermal efficiency. ASHRAE 90.1 compliant.

Ⓞ Standard gear capacities may change depending on burner supplier.

Designer must use gear capacities from the above chart to size the oil distribution piping system; including transfer pumps (if used).

* The information presented is for Natural gas 0.6 S.G.—For operation with Propane (LP gas), consult factory.

Dimensions are in inches unless otherwise specified.

For standard and optional equipment, see form PV 8403.

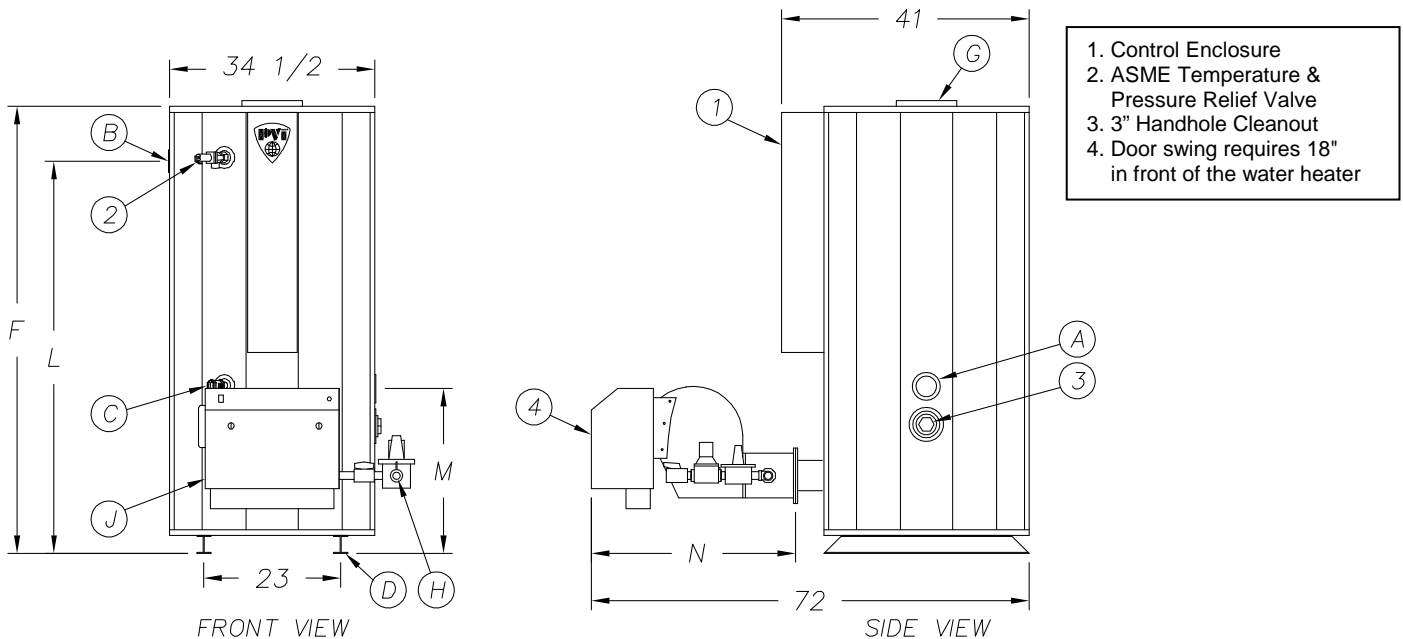

1. Control Enclosure
2. ASME Temperature & Pressure Relief Valve
3. 3" Handhole Cleanout
4. Door swing requires 18" in front of the water heater

STANDARD ELECTRICAL REQUIREMENTS:
CONTROL VOLTAGE: 120V, 1Ø, 60 HZ., 2 AMPS
MOTOR VOLTAGE: 120V, 1Ø, 60 HZ.
 SEE ABOVE CHART FOR BLOWER MOTOR AMPS

VENTING REQUIREMENTS:
 -.02" TO -.06" W.C. (NEGATIVE PRESSURE).
THE ENTIRE VENT SYSTEM SHOULD NEVER BE SIZED BASED UPON THE VENT CONNECTION DIAMETER EXCLUSIVELY.
FOR PROPER SIZING, CONSULT THE NATIONAL FUEL GAS CODE UNDER "FAN-ASSISTED".

PVI RESERVES THE RIGHT TO CHANGE THE DESIGN AND SPECIFICATION WITHOUT NOTICE.