

## Installation, Operation & Maintenance Manual

# MAXIM Gas, Oil & Gas/Oil Water Heater

**Important:** This manual contains information required for installation, operation and maintenance of this equipment. Read and follow the information in this manual and all other provided instructions, labels and markings before installing, operating or servicing this unit.

Installation and service must be performed by a qualified service installer, service agency or the gas supplier.



**To the installer:** After installation, these instructions must be given to the equipment user or left near the appliance.

**Special instructions to the owner:** Retain this manual for future reference. These instructions contain important information that will help you in maintaining and operating this appliance.



Hot Water Solutions

# MAXIM WATER HEATER

## TABLE OF CONTENTS

- 1. Safety Considerations**
- 2. Product Description**
- 3. Water Heater Installation**
  - 3.1 Checking Equipment Before You Install
  - 3.2 Codes
  - 3.3 Electrical Requirements
  - 3.4 Handling and Location
  - 3.5 Installation
  - 3.6 Service Clearances
  - 3.7 Clearances to Combustible Surfaces
  - 3.8 Other Codes and Regulatory Clearances and Requirements
- 4. General Piping Guidelines**
  - 4.1 Inlet and Outlet Connections
  - 4.2 Typical Piping Diagrams
- 5. Gas Supply and Piping**
  - 5.1 Gas Train and Controls Certification
  - 5.2 Gas Control Train
  - 5.3 Inlet Pressure
  - 5.4 Manifold Pressure
  - 5.5 Gas Piping Size
  - 5.6 Appliance Isolation During Gas Supply Piping Pressure Test
  - 5.7 Gas Connection
- 6. Combustion and Ventilation Air**
  - 6.1 Equipment Located in Confined Spaces
- 7. Venting**
- 8. Operating and Safety Controls**
  - 8.1 Temperature and Pressure Relief Valve(s)
  - 8.2 Operating Temperature Control
  - 8.3 High Water Temperature Limit Control
  - 8.4 Cathodic Protection
  - 8.5 Electronic Low Water Cut-off (Optional)
- 9. TEMPTRAC Electronic Controller Panel**
  - 9.1 Principle of Operation
  - 9.2 Upper LED Readout
  - 9.3 Lower LED Readout
  - 9.4 Control Buttons
  - 9.5 Key Combinations
  - 9.6 LED Icon Legend
  - 9.7 To View the Setpoint
  - 9.8 To Change the Setpoint
  - 9.9 To Set the Current Time and Day (Military Time)

# MAXIM WATER HEATER

9.10 To Set the Energy Saving Time (Nighttime Setback)

9.11 To Set Modulation Parameters

9.12 To Change Other Parameters

9.13 LED Display Alarm Messages

9.14 Audible Alarm

9.15 Alarm Recovery

## **10. Initial Startup Requirements**

10.1 Tools and Instrumentation Required

10.2 Resources

10.3 On Site Considerations

## **11. Startup Procedures and Operation**

## **12. Initial Firing and Adjusting of Burner**

12.1 Gas Burners

12.2 Oil Burners

## **13. Periodic Maintenance**

## **14. Recommended Maintenance Schedule**

## **15. Requirements for the Commonwealth of Massachusetts**

# MAXIM WATER HEATER

## 1 SAFETY CONSIDERATIONS

**WARNING: If the information in the supplied manual(s) is not followed exactly, a fire, explosion or exposure to hazardous materials may result, causing property damage, personal injury or death.**

**AVERTISSEMENT. Assurez-vous de bien suivre les instructions données dans cette notice pour réduire au minimum le risque d'incendie ou d'explosion ou pour éviter tout dommage matériel, toute blessure ou la mort**

### FOR YOUR SAFETY

- **Do not** store or use gasoline or other flammable vapors or liquids in the vicinity of this or any other appliance.
- **Ne pas** entreposer ni utiliser d'essence ou ni d'autres vapeurs ou liquides inflammables à proximité de cet appareil ou de tout autre appareil.

### WHAT TO DO IF YOU SMELL GAS

- **Do not** try to light any appliance.
- **Do not** touch any electric switch; do not use any phone in your building.
- **Immediately** call your gas supplier from a location away from your building and the smell of gas. Follow the gas supplier's instructions.
- If you cannot reach your gas supplier, call the fire department.

### QUE FAIRE SI VOUS SENTEZ UNE ODEUR DE GAZ:

- Ne pas tenter d'allumer d'appareil.
- Ne touches à aucun interrupteur; ne pas vous servir des téléphones se trouvant dans le bâtiment.
- Appelez immédiatement votre fournisseur de gaz depuis un voisin. Suivez les instructions de fournisseur.
- Si vous ne pouvez rejoindre le fournisseur, appelez le service de incendies.

Installation and service must be performed by a qualified installer, service agency or the gas supplier.

L'installation et l'entretien doivent être assurés ou un service d'entretien qualifié ou par le fournisseur de gaz.

This product contains, or may come to contain materials that have been identified as carcinogenic, or possibly carcinogenic to humans. Before installing, servicing or removing this product, read and follow the supplied instructions

Clearance in accordance with the local installation codes and the requirements of the gas supplier.

Dégagement conforme aux codes d'installation locaux et aux exigences du fournisseur de gaz.

Should overheating occur or the gas supply fail to shut off, turn off the manual gas control valve to the appliance.

En cas de surchauffe ou si l'alimentation en gaz ne s'arrête pas, fermez manuellement le robinet d'arrêt de l'admission de gaz.

**WARNING: Installation and service must be performed by a qualified installer, service agency or the gas supplier, who must read and follow the supplied instructions before installing, servicing or removing this appliance. Refer to the information contained in this manual. Improper installation, adjustment, alteration, service or maintenance can cause property damage, personal injury, exposure to hazardous materials or death.**

**WARNING: Do not use this appliance if any part has been under water. Immediately call a qualified service technician to inspect the unit and to replace any part of the control system, all gas controls and all other items affecting safe appliance operation and which has been under water.**

**AVERTISSEMENT: N'utilisez pas cet appareil s'il a été plongé dans l'eau, même partiellement. Faites inspecter l'appareil par un technicien qualifié et remplacez toute partie du système de contrôle et toute commande qui ont été plongés dans l'eau.**

**WARNING: In an emergency shut the main gas supply valve to the appliance from a location safely away from the emergency. Failure to follow these instructions can cause property damage, personal injury, and exposure to hazardous materials or death.**

# MAXIM WATER HEATER

## PRODUCT SAFETY INFORMATION REFRACTORY CERAMIC FIBER PRODUCT WITH CRYSTALLINE SILICA

**WARNING:** This product contains or may come to contain crystalline silica, which has been identified by the International Agency for Research on Cancer (IARC) as carcinogenic to humans. This product also contains refractory ceramic fibers, which have been identified by the IARC as possibly carcinogenic to humans. Avoid breathing fiber particulates and dust.

### **RISKS:**

- Air borne fibrous insulation is a possible cancer hazard by inhalation.
- Airborne crystalline silica may cause silicosis (lung disease) by inhalation.
- May cause temporary irritation to eyes, skin, and respiratory tract.

### **PRECAUTIONARY MEASURES:**

- Minimize airborne fibers with engineering controls.
- Use NIOSH/MSHA approved respirators as required (see MSDS).
- Wear long sleeved, loose-fitting clothing, eye protection and gloves.

### **FIRST AID MEASURES:** (If any of the irritations listed persists, seek medical attention)

- Eyes: Flush with water.
- Skin: Wash with soap and warm water.
- Ingestion: Do not induce vomiting. Get medical attention if gastrointestinal symptoms develop.
- Inhalation: Remove to fresh clean air.

**WARNING:** If you are unfamiliar with the safe handling of refractory ceramic fiber products, or if you wish additional information prior to beginning any disassembly of the water heater or boiler that might expose refractory ceramic fiber materials, contact: Unifrax Corporation, 2351 Whirlpool Street, Niagara Falls, NY 14305-2413, 1-800-322-2293.

### **IDENTIFICATION OF REFRACTORY CERAMIC FIBER MATERIALS (RCF):**

The burner assembly utilizes RCF material. (The RCF materials are located within the product and not generally exposed except during service, disassembly or assembly.)

## MAXIM WATER HEATER

### **IMPORTANT SAFETY NOTE**

*It takes only 5 seconds of skin contact with 140°F water to cause a second degree burn! You must protect against high water temperatures at all lavatories, tubs, showers and other points of hot water contact.*

**Accidental scalding from high water temperatures is a greater risk in some types of installations. Some examples are:**

**HOMES FOR THE MENTALLY HANDICAPPED  
HOMES FOR THE PHYSICALLY HANDICAPPED  
HOSPITALS AND NURSING HOMES  
ELDER CARE FACILITIES AND REST HOMES  
ORPHANAGES AND CHILD CARE FACILITIES**

**OTHER INSTALLATIONS – WHERE RESPONSE TO CONTACT WITH HOT WATER MAY BE SLOWER OR WHERE THE DANGER OF HOT WATER CONTACT IS GREATER**

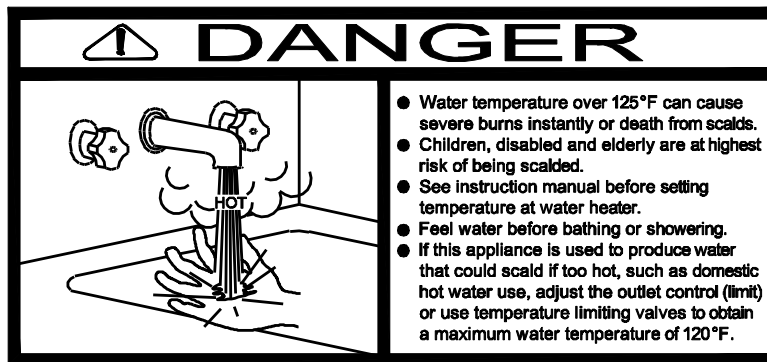

**Thermostatically controlled mixing valves must be used in the design of the potable hot water system.**

**Potable hot water should be tempered to no more than 110°F when used for bathing or other personal use.**

**Good engineering practice mandates the use of thermostatically controlled mixing valves set at 120°F to keep the delivered water temperature below scalding temperatures.**

# MAXIM WATER HEATER

## 2 PRODUCT DESCRIPTION Component, Controls and Connection Locations (Locations and Connections May Vary)

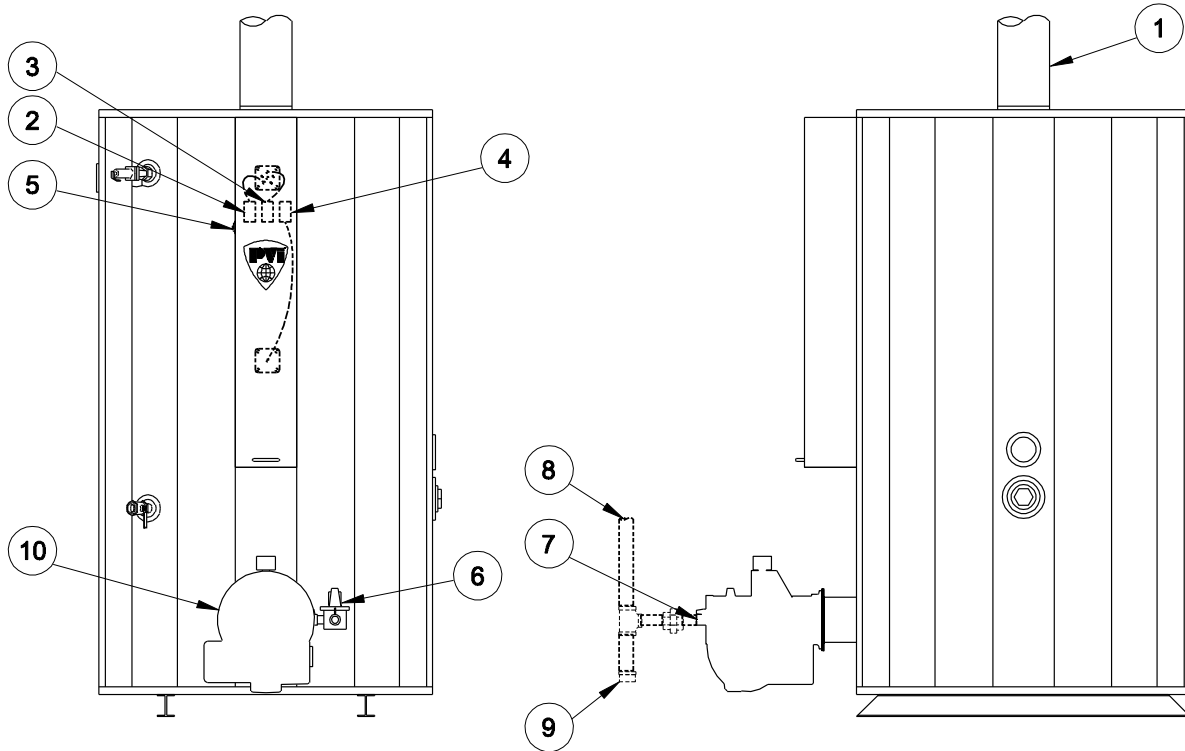

- |  |                                   |
|--|-----------------------------------|
| 1. Flue stack *                                  | 5. Control switch(es) and fuse(s) |
| 2. Temperature limiting device<br>(set at 200°F) | 6. Gas valve                      |
| 3. Upper operating thermostat<br>(set at 130°F)  | 7. Gas inlet                      |
| 4. Operating thermostat<br>(set at 120°F)        | 8. Gas line *                     |
|  | 9. Drip leg *                     |
|  | 10. Burner                        |

(\* Not furnished by PVI)

For connection points on oil pumps, see Section 10 or specific burner manufacturer's installation and maintenance instructions.

# MAXIM WATER HEATER

## 3 WATER HEATER INSTALLATION

### 3.1 Checking Equipment Before You Install

- Inspect the unit completely upon receipt from the freight carrier before signing the bill of lading. Inspect the appliance and all accompanying parts for signs of impact or mishandling. Verify the total number of pieces shown on packing slips with those actually received. Contact the freight carrier immediately if any damage or shortage is detected.
- Check the data decal on the appliance. Be sure the electrical, water and gas supply is adequate for the installation.
- Carefully remove all side and top shipping supports and bracing. If possible, do not remove the wooden base/skid assembly until the product has been moved to its final location for installation and operation (see: Handling and Locating the Water Heater).

**WARNING: The fuel-fired burner supplied with this water heater may be removed, packaged and shipped separately to avoid damage during transport and handling. Confirm the burner decal data matches with the water heater's rating decal data before mating in the field (i.e. Model, BTU/hr input, and Energy Source).**

**CAUTION:** The hot and cold water distribution system piping connected to this product must be suitable for 150 psi at 210°F in the event the water heater controls malfunction.

### 3.2 Codes

The equipment must be installed in accordance with those installation regulations in force in the local area where the installation is to be made. Authorities having jurisdiction must be consulted before installation is made. In the absence of such requirements, the installation must be in accordance with the instructions in this manual, appliance markings and supplemental instructions and in compliance with the latest edition of the National Fuel Gas Code, ANSI Z223.1/NFPA 54. Where required by the Canadian authority having jurisdiction, the equipment must be installed in accordance with the latest edition of the CAN/CSA B149.1-10 Natural Gas and Propane Installation Code and applicable Provincial Regulations. All appliances conform to the current edition of the ASME Boiler and Pressure Vessel Code, Section IV, Part HLW.

### 3.3 Electrical Requirements

See appliance rating decal for electrical service requirements. The appliance must be electrically supplied and grounded in accordance with the requirements of the authority having jurisdiction or, in the absence of such requirements, with the latest edition of the National Electrical Code ANSI/NFPA No. 70. In Canada, the electrical service must conform to local electrical codes and/or CSA C22.1, Canadian Electrical Code, Part 1.

- All wiring between the unit and field installed devices must be made with properly rated stranded copper wire.
- Line voltage wire exterior to the appliance must be enclosed in approved conduit or approved metal clad cable.
- To avoid serious damage, **DO NOT** energize the unit until the system and appliance is full of water.

Utiliser du fil de cuivre de la taille appropriée pour le service électrique entrant. Les dommages résultant de l'utilisation de fil d'aluminium seront exclus du champ d'application de la garantie de cet appareil.

120V 1 phase, 60 Hz service wiring connections are located in the enclosure on the water heater. Some models may additionally have high voltage connections located on the burner.

Be certain that high and low voltages are connected to the correct points; also, check rotation of motors on three phase models. The burners are shipped separately from the heaters and are provided with connecting wires in conduit to be connected after the burner is in place in the combustion chamber. Wires and terminal block connections are marked for simplified hookup.

### 3.4 Handling and Locating the Water Heater

**WARNING: Use industry standard safe rigging methods, such as including the use straps and spreader bars and lifting from the water heater base skid assembly, when attempting to lift or move this product. Failure to follow industry safe rigging methods could result in property damage, serious injury or death.**

**WARNING: This product should NOT be oriented in any directions other than vertical. Failure to comply may result in equipment damage not covered by the warranty.**



# MAXIM WATER HEATER

1. These units are suitable for indoor installation only (unless specified).
2. Locate the unit so that if water connections should leak, water damage will not occur. When such locations are unavoidable, install a suitable drain pan, and plumb pan to ensure adequate drainage in the event of a leak. Under no circumstances is the manufacturer responsible for water damage in connection with this unit, or any of its components. The manufacturer's warranty does not cover water damage.
3. Protect associated electrical components and electrical connections from water (dripping, spraying, rain, etc.) during appliance operation and service.
4. Place the appliance on a level, non-combustible floor. Concrete over wood is not considered non-combustible.
5. Do not install on carpet or other combustible floor coverings. If installation over a combustible floor is required, follow these guidelines:
  - Use a base of hollow clay tile or concrete blocks from 8" to 12" thick and extending 24" beyond the sides.
  - Place the blocks in line so that the holes line up horizontally to provide a clear passage through the blocks.
  - Install 1/2" fireproof millboard with a 20-gage sheet metal cover over the block base.
  - Center the unit on the base. Also follow this procedure if electrical conduit runs through the floor, and beneath the appliance. A field-installed base must meet all local fire and safety code requirements.

## 3.5 Installation

**WARNING: Some units are top heavy. Use caution when moving and rigging these products.**

1. Connections to the cold water inlet and hot water outlet should be installed with shut-off valves and unions so that the unit may be disconnected for servicing. Use caution when threading pipe nipples into tank connections to prevent cross threading, or over-tightening. Always use a back-up wrench on tank nipples when tightening unions, valves, etc.

**IMPORTANT:** Do not use galvanized or steel pipe nipples when making connections to the tank. Use non-ferrous nipples only.

2. Some tank fittings will be attached to the tank wall with studs. Check these type fittings for leaks after filling tank. Do not over-tighten the studded connections as damage to the O-ring under the fittings may occur. A maximum torque of (15) ft. lbs. (unlubricated) should be used on studded connections - tighten only in alternating pattern.
3. Hot water and return circulation lines should be insulated. Cold water supply lines should be insulated if subject to freezing during shutdown periods.
4. A thermal expansion valve (or diaphragm-type expansion tank) should be installed in the cold water line between the water heater and any check valve.

**IMPORTANT:** Do not use the plumbing connected to the appliance as a ground for welding or any other purpose.

5. The water heater is equipped with a temperature and pressure relief valve rated for the input of the energy source and the working pressure of the tank. The relief valve discharge should be piped to a suitable open drain. The drainpipe may not be smaller than the relief valve opening and must be secured to prevent it from lifting out of the drain under discharge pressure. Do not install valves or restrictions in the discharge line. Storage tanks must have over pressure protection. If not factory installed, a properly rated temperature and/or pressure relief valve must be installed in the fitting furnished for that purpose.
6. The drain valve should be piped to a suitable open drain.

## 3.6 Service Clearances

Clearances for servicing and inspection must be 18" minimum at sides and rear and 24" minimum in front. Optional equipment may increase the clearance requirements. Allow sufficient space for installing and servicing connections such as water, gas, vent, combustion air, electrical, pump and other auxiliary equipment.

## 3.7 Clearances To Combustible Surfaces

The minimum clearance to unprotected combustible material must be 8" min. at top, sides and rear, and 24" min. in front. Minimum 1" clearance must be provided from any vent surface to adjacent combustible material.

# MAXIM WATER HEATER

## 3.8 Other Code and Regulatory Clearances and Requirements

Additional clearance beyond the minimum required to combustibles materials and other requirements may be required to comply with local, state or national codes and regulations. It is to the responsibility of the installer to comply with these requirements. Examples of codes or regulations that may apply are the National Electric Code, State/Regional/National drain water and flue emissions regulations, the National Fuel Gas Code, Building Construction and Safety Codes, the Americans with Disabilities Act (ADA) and, in states where a water heater above a certain input or storage capacity is considered a boiler, the applicable boiler code requirements, the applicable boiler installation requirements in "Safety Code for Controls and Safety Devices for Automatically Fired Boilers" (CSD-1) and other regulatory requirements.

## 4 GENERAL PIPING GUIDELINES

### 4.1 Inlet and Outlet Connections

1. Use only non-ferrous water piping and fittings. Do not use galvanized pipe or fittings. Use of ferrous or galvanized pipe or fittings can cause rust to form.
2. Install shut-off valves and unions on the inlet and outlet water piping for servicing. Use caution when threading pipe nipples into tank connections to prevent cross threading, or over-tightening. Always use a back-up wrench on tank nipples when tightening unions, valves, etc.
3. Insulate hot water and return circulation lines. Insulate cold water supply lines if subject to freezing during shutdown periods. **IMPORTANT:** Do not use the plumbing connected to the appliance as a ground for welding or any other purpose.
4. Pipe the drain valve to a suitable open drain capable of receiving discharge temperatures up to 212°F.

### 4.2 Typical Piping Diagrams

To maximize water heater efficiency, connect the building return ( $\approx 5$  gpm) to the inlet piping as shown below.

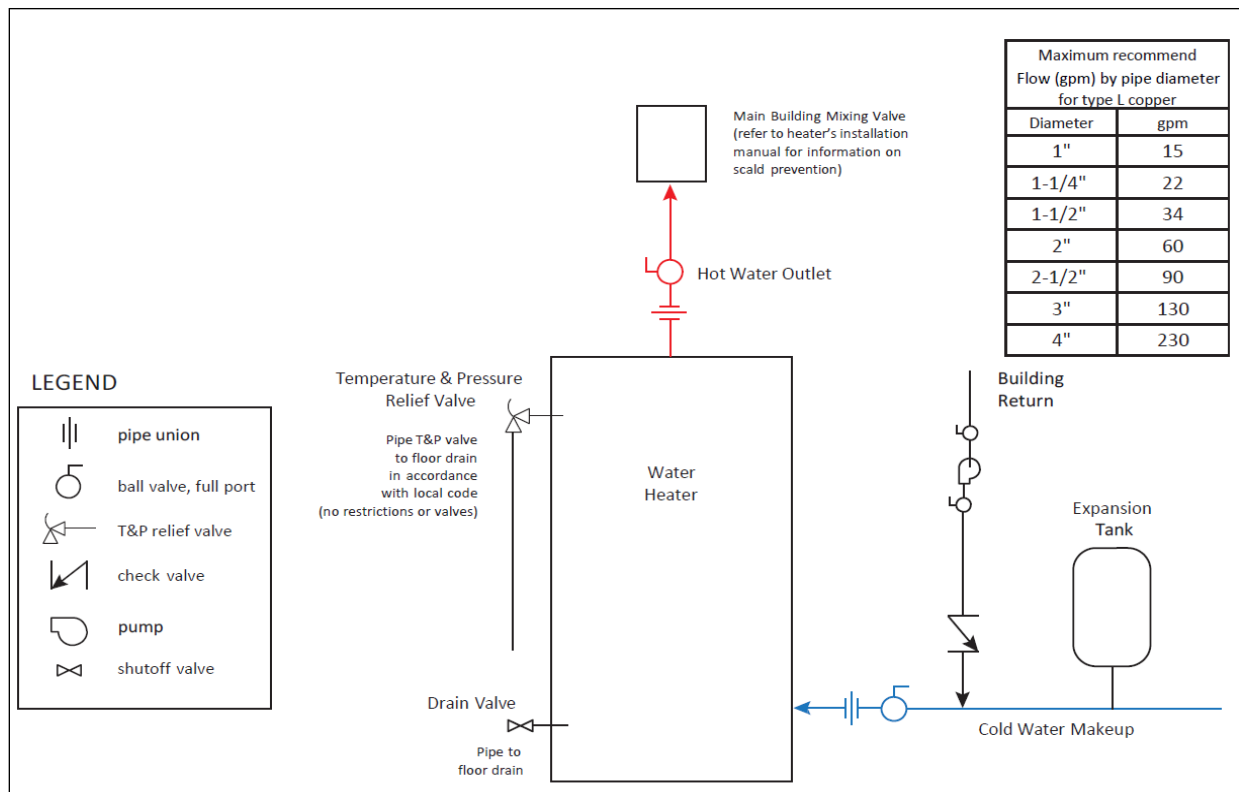

Single Water Heater – One Hot Outlet Temperature

# MAXIM WATER HEATER

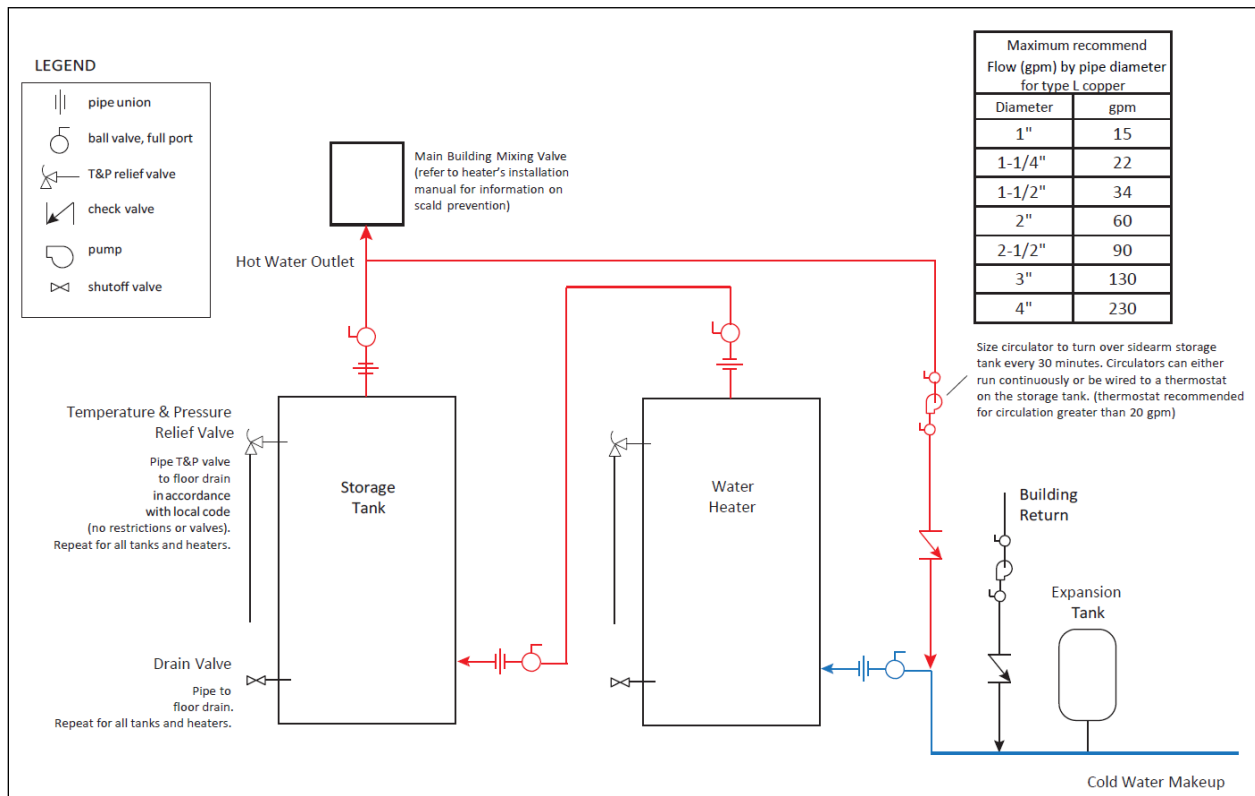

One Water Heater – One Sidearm Storage Tank

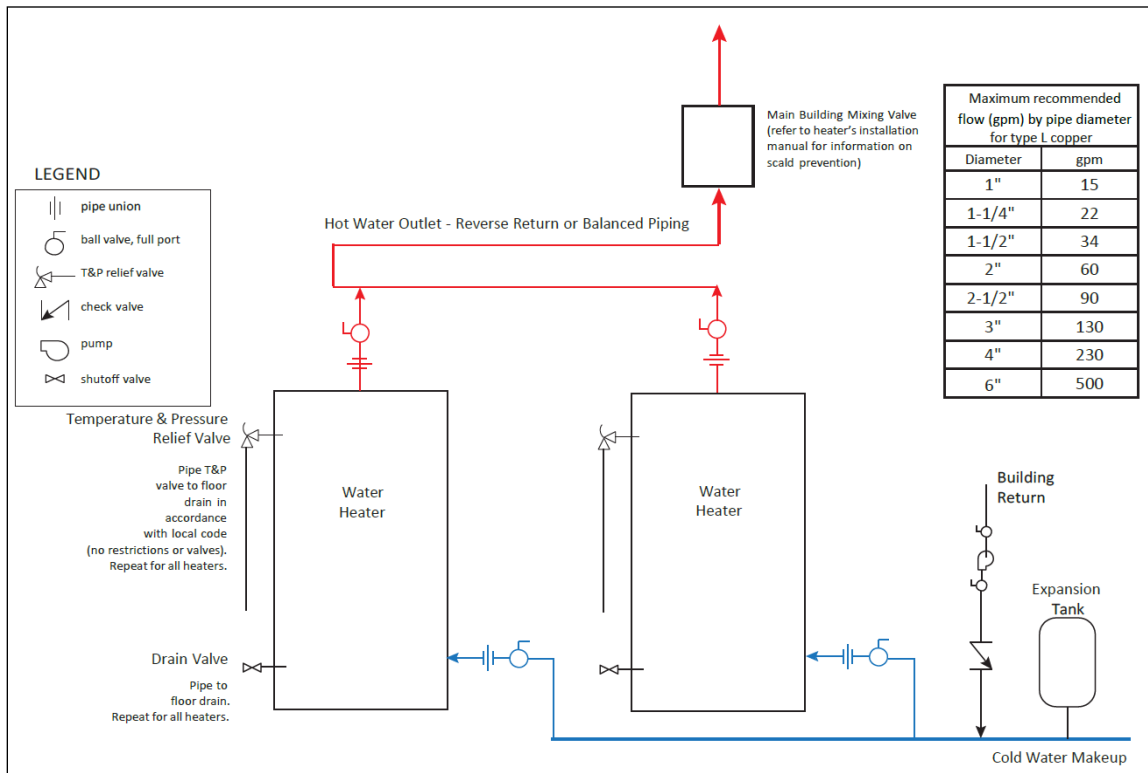

Two Water Heaters – Single Hot Outlet Temperature

# MAXIM WATER HEATER

## 5 GAS SUPPLY AND PIPING

Verify that the type of gas specified on rating plate is supplied to the unit. This unit is designed for operation up to 2000 feet altitude. Appliance Btuh output derates 4% per 1000 feet elevation above sea level. Consult Factory for installations above 2000 feet elevation.

### 5.1 Gas Train and Controls Certification

The gas train and controls assembly provided on this unit have been tested under the applicable Nationally Recognized Standard to comply with safety and performance criteria such as proper ignition, combustion and safety shutdown operation.

### 5.2 Gas Control Train

All models include gas control trains with the following components: main manual shutoff valve, two safety shutoff valves, gas regulator and a final manual valve with the manifold pressure tap on the side of the valve. These components may be separate or two or more may be combined in a common housing.

**WARNING: Do not adjust or remove any screws or bolts on gas train control components which are secured with a red or blue sealing compound. In addition to voiding warranties and certification listings, such adjustment or disassembly can cause improper operation which could result in property damage, personal injury or death.**

### 5.3 Inlet Pressure

Measure at the inlet pressure tap located at the main gas cock. The inlet pressure must remain within the minimum and maximum values while the unit is at rest and while the unit is operating at maximum firing rate.

Input Btu/h Natural Gas	270,000	399,000	540,000	720,000	800,000	1,000,000	1,200,000
Minimum Flow Gas Pressure - " W.C.	4.5	4.5	4.5	4.5	4.5	4.5	6.0
Maximum Static Gas Pressure - " W.C.	10.5	10.5	14.0	14.0	14.0	14.0	14.0

Input Btu/h Propane Gas	270,000	399,000	540,000	720,000	800,000	1,000,000	1,200,000
Minimum Flow Gas Pressure - " W.C.	8.0	8.0	11.0	11.0	11.0	11.0	11.0
Maximum Static Gas Pressure - " W.C.	13.0	13.0	14.0	14.0	14.0	14.0	14.0

### 5.4 Manifold Pressure

Measure at the pressure tap located downstream side of the manual valve closest to the burner. The rated manifold pressure appears on the product data label located near the front of the appliance.

### 5.5 Gas Piping Size

Do not use the gas pipe connection size to determine the gas supply piping. Designing and sizing a gas supply piping system requires consideration of many factors and must be done by a gas supply piping expert. Always follow NFPA 54 National Fuel Gas Code for gas pipe sizing and gas pipe system design. The following charts provide examples of some of the information used by the gas supply piping expert to determine proper pipe sizes.

Use the values in the following table to add the equivalent straight pipe for each elbow or tee to obtain the total distance from the meter:

CONVERT FITTINGS TO EQUIVALENT STRAIGHT PIPE*								
Diameter Fitting (inches)	¾"	1"	1¼"	1½"	2"	3"	4"	5"
Equivalent Length of Straight Pipe (feet)	2'	2'	3'	4'	5'	10'	14'	20'

# MAXIM WATER HEATER

Use the following table to determine the possible pipe size based on distance from gas meter for a Single Unit Installation using Schedule Metallic Gas Pipe.\*

Equivalent Feet From Meter	SINGLE UNIT INSTALLATION SUGGESTED PIPE SIZE Maximum Capacity for Natural Gas* MBTU/HR Based on 0.5" W.C. Pressure Drop**					
	1-1/4"	1-1/2"	2"	2 1/2"	3"	4"
25	860	1320	2475	3900	7000	-
40	660	990	1900	3000	5300	-
60	-	810	1520	2400	4300	-
80	-	690	1300	2050	3700	-
100	-	620	1150	1850	3250	6700
125	-	-	1020	1650	2950	6000
150	-	-	950	1500	2650	5500
175	-	-	850	1370	2450	5000
200	-	-	800	1280	2280	4600

\*See NFPA 54 National Fuel Gas Code for actual pipe size selection and for sizing Propane gas piping

MULTIPLE UNIT INSTALLATIONS SCHEDULE 40 METALLIC GAS PIPE SIZE CHART*														
Maximum Capacity of Pipe in Thousands of BTU's per hour for gas pressures of 14 Inches Water Column (0.5 PSIG) or less and a pressure drop of 0.05 Inch Water Column (Based on NAT GAS, 1025BTU's per Cubic Foot of Gas and 0.60 Specific Gravity).*														
Nominal Iron Pipe Size, Inches	Length of Pipe in Straight Feet													
	10	20	30	40	50	60	70	80	90	100	125	150	175	200
3/4	369	256	205	174	155	141	128	121	113	106	95	86	79	74
1	697	477	384	328	292	267	246	256	210	200	179	164	49	138
1 1/4	1400	974	789	677	595	543	502	472	441	410	369	333	308	287
1 1/2	2150	1500	1210	1020	923	830	769	707	666	636	564	513	472	441
2	4100	2820	2260	1950	1720	1560	1440	1330	1250	1180	1100	974	871	820
2 1/2	6460	4460	3610	3100	2720	2460	2310	2100	2000	1900	1700	1540	1400	1300
3	11200	7900	6400	5400	4870	4410	4000	3800	3540	3300	3000	2720	2500	2340
4	23500	16100	13100	11100	10000	9000	8300	7690	7380	6870	6150	5640	5130	4720

\*See NFPA 54 National Fuel Gas Code for actual pipe size selection and for sizing Propane gas piping

## 5.6 Appliance Isolation during Gas Supply Piping Pressure Test

1. The appliance and its provided manual shutoff valve must be disconnected from the gas supply piping system during any pressure testing of that system at test pressures in excess of 1/2 PSI (3.5 kPa).
2. The appliance must be isolated from the gas supply piping system by closing its individual manual shutoff valve during any pressure testing of the gas supply piping system at test pressures equal to or less than 1/2 PSI (3.5 kPa).
3. The appliance and its gas connection must be leak-tested before placing it in operation.

## 5.7 Gas Connection

1. Safe operation of unit requires adequate gas supply with the required static and dynamic (flow) pressures. Actual piping selection depends on many variables that must be carefully considered by the gas piping system designer.
2. Do not select gas pipe sizes based only on the supplied tables. These tables are for use by the gas piping system designer as a reference in checking pipe size selections.
3. Gas pipe size may be larger than heater connection.
4. Installation of a union is suggested for ease of service.
5. Install a manual main gas shutoff valve on the gas supply piping connected to the appliance to isolate the burner and gas train from main supply gas in compliance with NFPA 54 National Fuel Gas Code and most local Codes.
6. The gas system installer must clearly identify the emergency shut-off device.
7. A sediment trap (drip leg) MUST be provided in the inlet of the gas connection to the unit.
8. Gas valves and gas regulators may contain bleed or vent ports. Local codes may require bleeds and vents to be vented to atmosphere outside the building. Consult local building codes for size and installation.

# MAXIM WATER HEATER

## 6 COMBUSTION AND VENTILATION AIR

Provisions for adequate combustion and ventilation air to the mechanical room must be in accordance with Section "Air for Combustion and Ventilation" in the latest edition of the NFPA 54 National Fuel Gas Code, ANSI Z223.1 and/or CAN/CSA B149, Installation Codes or applicable provisions of the local building codes. Any method addressed in NFPA 54 National Fuel Gas Code section "Air for Combustion and Ventilation" is acceptable and several are outlined below.

### 6.1 Equipment Located In Confined Spaces

Equipment located in confined spaces requires two openings, one commencing within 12" (30.5 cm) from the top of the enclosure/room and one commencing within 12" from bottom of the enclosure/room to assure adequate combustion air and proper ventilation. The total input of all gas utilization equipment installed in the room must be used to determine the required minimum air volume needed for combustion, ventilation and dilution of flue gasses. Also consider makeup air requirements from other equipment within the mechanical room or other rooms that are pressure connected with the mechanical room. Some examples of other makeup air requirements are from kitchen exhaust hoods, clothes dryers, powered exhaust fans, etc.

- **All Air From Outdoors:**

Each opening requires a minimum free area of 1 square inch per 4000 Btu/hr of the total input rating of all appliances in the enclosure, if directly communicating with the outdoors or communicating to the outdoors through vertical ducts.

Each opening requires a minimum free area of 1 square inch per 2000 Btu/hr of the total input rating of all appliances in the enclosure, if communicating with the outdoors through horizontal ducts.

- **All Air From Inside The Building:**

Follow the requirements of NFPA 54 National Fuel Gas Code, ANSI Z223.1 section "Indoor Combustion Air".

- **Combination Of Air From The Indoors And From The Outdoors:**

Follow the requirements of NFPA National Fuel Gas Code, ANSI Z223.1 section "Combination Indoor and Outdoor Combustion Air".

**WARNING: Adequate clean combustion air must be provided to the appliance. The appliance must never operate under a negative pressure. Particular care must be taken when exhaust fans, compressors, air handling units, etc. may rob air from the appliance. The combustion air supply must be completely free of any chemicals or fumes, which may be corrosive to the appliance. Some common chemical fumes to avoid are fluorocarbons and other halogenated compounds, most commonly present as refrigerants or solvents, such as Freon, trichloroethylene, perchlorethylene, chlorine, etc. These chemicals, when in contact with the equipment or when burned, form acids which quickly attack the tubes, flue collector, stack and other appliance and auxiliary equipment. Failure to provide adequate clean combustion air or operating under negative pressure can cause premature, unwarranted product failure or unsafe operation producing carbon monoxide that could escape into the building. Exposure to carbon monoxide can lead to personal injury or death.**

## 7 VENTING

When properly installed with UL, ULC, ETL or CSA listed Category I venting, the appliance operates with a non-positive vent static pressure and with a vent gas temperature that **avoids excessive condensate production in the vent.**

Category I venting should terminate above the roof surface and must be installed in accordance with the "Venting of Equipment" section of the current edition of the National Fuel Gas Code, ANSI Z223.1 / NFPA 54 or, in Canada, the "Venting Systems and Air Supply for Appliances" section of the current edition of the CAN/CSA B149.1-10 Installation Codes, or applicable provisions of the local building codes.

- Do not use the vent connection size to determine the necessary vent connector, vent or stack size. For proper sizing use the National Fuel Gas Code "Fan-assisted" table.
- Locate unit(s) as close as possible to the vent or stack. The vent connector from the appliance vent connection to the vertical vent or stack that terminates outside and above the building roof must be made with listed Type "B" double wall (or equivalent), must be as direct as possible and must have no blockage or reduction in diameter.
- Support horizontal portions of the venting system to prevent sagging. Horizontal runs must slope upwards not less than 1/4 inch per foot (21 mm/m) from the appliance to the vent terminal. Follow manufacturer's instructions.

# MAXIM WATER HEATER

- Do not attach the vent connector of any appliance vented by natural draft to any portion of a mechanical draft system operating under positive pressure.
- A barometric damper (draft control) is supplied with all models. Attach the properly sized vent increaser to the water heater vent connection with three sheet metal screws. A properly installed and adjusted barometric damper helps stabilize draft and regulate high updraft. Conventional vented multiple unit installations with combined venting require barometric dampers to regulate draft at each unit. Adjust the barometric damper to 0.04 inches water column updraft, when used. Follow the barometric damper manufacturer's installation instructions.
- **The draft in vent should be within a range of -.02 and -.08" W.C.**
- A UL, ULC, ETL or CSA listed vent terminal, suitable for Category I products, **must** be installed to adequately protect the gas vent from wind and weather.
- The vent terminal must extend at least 3 ft (.09 m) above the highest point where it passes through the roof of a building and at least 2 ft (.06 m) higher than any portion of a building within a horizontal distance of 10 ft. (3.0 m).
- The vent cap must terminate at least 3 feet (0.91 m) above any forced air inlet within 10 feet (3.05 m); 4 feet (1.22 m) below, 4 feet (1.22 m) horizontally from or 1 foot (0.3 m) above any door, window or gravity air inlet to the building; 1 foot (0.3 m) above grade, 1 foot (0.3 m) above the highest snow levels and must terminate at least 7 feet (2.13 m) above grade when located adjacent to public walkways or gathering areas.
- The vent terminal must not be installed closer than 3 feet (0.91 m) from an inside corner of an L-shaped structure.

**WARNING: Do not combine appliances utilizing Category I or Category II venting into the same vent system with appliances utilizing Category III or Category IV venting. This could cause unsafe operation and the potential for poisonous carbon monoxide to enter occupied areas. Such improper installation can cause property damage, personal injury, exposure to hazardous materials or death.**

## 8 OPERATING AND SAFETY CONTROLS

**WARNING: Turn off all electrical service to the appliance when accessing the limit or other controls located inside the control cabinet or inside the burner vestibule inside the top of the appliance. Close and fasten the control cabinet and burner vestibule cover before restoring electrical service to the appliance. The cabinet and burner vestibule contain High Voltage wiring and terminals. If the electrical service is not turned off and these terminals are touched, a dangerous shock causing property damage, personal injury or death could occur.**

**Coupez l'alimentation avant intervention sur l'appareil.**

### 8.1 Temperature and Pressure Relief Valve(s)

A Temperature and Pressure Relief Valve(s) sized in accordance with the ASME Boiler and Pressure Vessel Code, Section IV HLW is installed in the tank.

**WARNING: Secure the relief valve discharge pipe to a suitable floor drain such that very hot water does not openly splash during a significant relief valve discharge. If the relief valve discharge pipe is not routed and secured to a suitable drain, hot water discharge can result in property damage, scalding and personal injury or death.**

- Follow the temperature and pressure relief valve manufacturer's installation instructions and all local, regional and national codes applicable to temperature and pressure relief valve installation and discharge piping.
- The relief valve discharge pipe must not be smaller than the relief valve opening and must be secured to prevent it from lifting out of the drain under discharge pressure and must be routed to allow complete drainage of the valve and line.
- Do not plug the relief valve (s) or install a reducing coupling, valve or other restriction in the relief valve(s) discharge line(s), as this will eliminate the critical water temperature and pressure protection it provides.
- Thermal Expansion - A relief valve that periodically discharges may result from thermal expansion if the water heater is installed in a system closed by components, such as a backflow preventer or check valve in the cold water supply. These systems must be provided with means to control expansion. Contact a water heater or plumbing professional to resolve this situation.

# MAXIM WATER HEATER

**WARNING: Do not plug the relief valve(s), use discharge piping smaller than the relief valve opening or install a reducing coupling, valve or other restriction in the relief valve discharge line. Failure to comply with these relief valve and discharge piping requirements can prevent the relief valve from providing its intended temperature and pressure protection, which can result in a sudden loss of pressure containment that can cause property damage, exposure to hazardous materials, personal injury or death.**

## 8.2 Operating Temperature Control

An adjustable digital operating control is located in the front control panel. The control is factory pre-set at approximately 120°F. To adjust the setpoint to deliver the desired water temperature, press and release the Set key on the face of the control. When setpoint adjustment is enabled, use the arrow keys to adjust the set point to the desired system temperature. See TempTrac Electronic Controller Panel in this manual for more information.

Le thermostat est réglé à environ 49 degrés Celsius. Températures de l'eau supérieures à 52 degrés Celsius peut causer instantanément de graves brûlures ou la mort de brûlures. Suivez les instructions dans le manuel d'installation pour modifier la température de l'eau.

## 8.3 High Water Temperature Limit Control

Appliances are equipped with adjustable limit and high limit controls to control the maximum discharge water temperature. These controls are located inside the control cabinet and are accessed by removing the bottom control panel cover. Pressing the reset on the High Limit Control will not cause the control to reset until the water temperature has dropped below the set point of the manual reset High Limit Control. The Lower Limit is of the auto reset type and can be dial adjusted to operate just above the set point of the main Operating Temperature Control.

## 8.4 Cathodic Protection

PVI water heaters do not utilize cathodic protection. However, in hot water systems utilizing cathodic protection, hydrogen gas can be produced when the hot water system has not been used for a long period of time (generally two weeks or more).

**WARNING: Hydrogen gas is extremely flammable.**

To prevent the possibility of injury under these conditions, one of the hot water system faucets should be opened for several minutes before using any electrical device connected to the hot water system. If hydrogen is present, there will be an unusual sound such as air escaping through the pipe as the hot water begins to flow. Do not smoke, have open flames or turn electrical switches on or off near the faucet at the time it is open.

## 8.5 Electronic Low Water Cut-Off (Optional)

When the water level is above the electrode position in the tank, the reset pushbutton will energize the control (LED will be lit). The control remains energized until the water level recedes below the electrode position (LED will not be lit). Unless otherwise specified, there is a three-second time delay on decreasing level. Water level must be below tank probe location for full three seconds before control de-energizes.



# MAXIM WATER HEATER

## 9 TEMPTRAC™ ELECTRONIC CONTROLLER PANEL

### 9.1 Principle of Operation

The water heater operates to satisfy the setpoint of the TempTrac digital control whose sensor is located near the energy source of the water heater tank. Demand (flow) will typically create a drop in temperature, thus activating the water heater to add heat to the stored water. This setpoint is the desired water temperature to maintain.

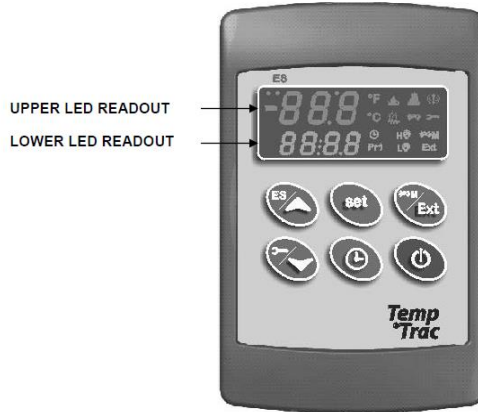

### 9.2 Upper LED Readout

The default display of the upper readout (Probe 2) is the water temperature near the hot water outlet.

This readout can display additional information by pushing the EXT button to cycle through the following items:

- The temperature reading from (Probe 3 if used) is located in the flue connection and monitors the flue gas temperature.
- The firing rate of the burner, if applicable, indicated by 0 to 100%.
- The temperature difference between Probe 1 and Probe 2.
- All of the display information described above is available for monitoring through the optional MODBUS RTU interface.

### 9.3 Lower LED Readout

The default display of the lower readout (Probe 1) is the water temperature sensed near the middle of the water heater tank. This sensing location serves as the primary control temperature for the TempTrac.

### 9.4 Control Buttons

<b>SET</b>	Displays and modifies the temperature set points. In programming mode, it selects a parameter or confirms an operation.
<b>UP</b>	Displays and modifies the energy saving (Night Time setback) settings. In programming mode, it browses the parameter codes or increases a displayed value.
<b>DOWN</b>	Displays the working hours of the load relays. In programming mode, it browses the parameter codes or decreases a displayed value.
<b>CLOCK</b>	Changes lower display from the stored water temperature to current time and day.
<b>EXT</b>	Changes upper display from Probe 1 temperature to Probe 3 temperature, displays the temperature difference of the stored water temperature minus Probe 2 temperature and firing rate of the burner from 0 to 100%. In programming mode it sets the 4-20mA output (password is required).
<b>ON/OFF</b>	Switches the control ON or OFF.

(See TempTrac User Manual PV500-41 for full description)















### 9.5 Key Combinations

- Use the **UP + DOWN** key to lock and unlock the keyboard.

# MAXIM WATER HEATER

- Use the **SET + DOWN** arrow to enter the programming mode.
- Use the **SET + UP** arrow to exit the programming mode.

## 9.6 LED Icon Legend

LED	MODE	Function
°F	ON	Temperatures are displayed in degrees Fahrenheit
°C	ON	Temperatures are displayed in degrees Celsius
	Flashing	Call for heat time delay or remote enable/disable is in standby (disabled)
	ON	Call for heat is on
	Flashing	Second stage time delay ( <i>On 2-stage units only</i> )
	ON	Second stage on or the <b>AL2</b> alarm output is enabled.
	Flashing	Output 3 time delay
	ON	Output 3 relay on
	ON	Modulation output signal is in manual control mode or forced to the <b>i1S</b> setting by digital input 1
	ON	Modulation output signal is automatically controlled by temperature probe 1
	Flashing	Modulation output time delay is activated.
<b>Ext</b>	ON	Probe 3 is displayed
	FLASHING	Digital input 2 (alarm) is activated
	FLASHING	Digital input 3 (alarm) is activated
	ON	Lower display is displaying the time
	FLASHING	Alarm signal
	FLASHING	Programmed working hours limit is exceeded
	ON	Working hours are displayed in Lower LED readout
<b>ES</b>	ON	The energy saving function is running

## 9.7 To View the Setpoint

- Push and release the **SET** key to see the set point value.
- To return to normal display, press **SET + UP** or wait 15 seconds without pressing any key.

## 9.8 To Change the Setpoint

- Push the **SET** key. The upper display will show the “St1” parameter name, while the lower display will show its value.
- Use the **UP** or **DOWN** key to cycle through the parameter names.
- Push the **SET** key to modify a parameter value. The value starts flashing in the lower display.
- To change it push the **UP** or **DOWN** keys. Push the **SET** key again to confirm the value and pass to the setting of next set point.
- Repeat the operations described at points 3, 4, 5.
- **To Exit:** press **SET + UP** or wait 15 seconds without pressing any key.

**NOTE:** Each point has a time out of 15 seconds. If any key is pushed within 15 seconds the controller exits the set points programming procedure.

**NOTE:** The set value is stored even when the procedure is exited by waiting the time-out to expire.

# MAXIM WATER HEATER

## 9.9 To Set the Current Time and Day (Military Time)

- Push and hold the **CLOCK** key for more than 3 seconds. The LED icon starts flashing and the “**Hur**” (hour) parameter name is displayed in the Upper LED readout, its value is displayed in the Lower LED readout.
- Pushing the **UP** or **DOWN** key alternates the LED readouts between the following:
  - “**Hur**” (hour) in the Upper readout and its value in the lower readout
  - “**Min**” (minute) in the Upper readout, its value in the Lower readout
  - “**dAY**” (day) in the Upper readout, its value in the Lower readout
- To adjust a value, press the **SET** key and the value in the Lower LED will start flashing. Change the value by pressing the **UP** or **DOWN** keys. When correct, press the **SET** key.
- To exit push **SET + UP** keys or wait 15 seconds without pressing any keys.

**NOTE:** This device recognizes Sunday as the first day of the week and Saturday as the last.

## 9.10 To Set the Energy Saving Time (Nighttime Setback)

- Push and hold the **UP** key for more than 3 seconds and the first parameter of the energy saving will be displayed.
- Use the **UP** or **DOWN** keys to browse them.
- To change a value, push the **SET** key followed by **UP** or **DOWN** and then the **SET** key again.
- To exit from the menu, press **SET** and **UP** or wait for 30 seconds.

## 9.11 To Set Modulation Parameters

- Push and hold the **EXIT** key for more than 3 seconds and the LED will switch **ON** and a passkey will be required to view and manually change the modulation % value. Passkey is “321”.
- Upon entering the password, the modulation % value will be displayed in the lower display.
- To manually adjust this value, push the **SET** key; the value will start flashing. Adjust it by using the **UP** or **DOWN** keys and then the **SET** key again.
- To exit from the menu, press **SET** and **UP** keys together or wait for 30 seconds.



## 9.12 To Change Other Parameters

- Push the **SET** and **DOWN** arrow simultaneously for 3 seconds.
- Select the required parameter. The name of the parameter is on the upper display; its value is on the lower display.
- Press the **SET** key: the value of the parameter will start blinking.
- Use **UP** or **DOWN** to change the value.
- Press **SET** to store the new value and move to the following parameter.
- **To Exit:** Press **SET + UP** or wait 15s without pressing a key.

# MAXIM WATER HEATER

## 9.13 LED Display Alarm Messages

Alarm messages are displayed in the upper LED readout and alternate with the default display. An alarm LED ICON is also illuminated.

ALARM MESSAGE	CAUSE	RESULTS OF ALARM CONDITION	RECOMMENDED ACTION
"P1"	TP1 probe failure	Inlet temperature sensor is not connected or is reading incorrectly. Call for heat and burner modulation output signal will revert to low fire.	Check wiring and sensor Terminals 14 & 17
"P2"	TP2 probe failure	Temperature sensor is not connected or is reading incorrectly.	Check wiring and sensor Terminals 15 & 17
"P3"	TP3 probe failure	Temperature sensor is not connected or is reading incorrectly or flue gas temperature protection is disabled.	Check wiring and sensor Terminals 16 & 17
"HA"	High temperature limit setpoint exceeded	Audible alarm sounds, operation continues.	Manual reset required
"LA"	Low temperature alarm	Audible alarm sounds, operation continues.	
AL1	Digital input 1 is activated.	Unit de-energized after timer delay. Audible alarm sounds.	Manually reset required
AL2	Digital input 2 is activated. This alarm indication is dedicated to the Alarm On Any Failure feature of this product.	Unit de-energized after timer delay. Audible alarm sounds. Alarm contacts close for remote indication of alarm. Internal alarm register will communicate an alarm condition through the Modbus RTU communication link.	Manually reset required
AL3	Digital input 3 is activated.	Unit de-energized after timer delay. Audible alarm sounds.	
Mn1	Maintenance alarm for output 1	Buzzer sounds, operation continues	Check wiring and sensor
Mn2	Maintenance alarm for output 2	Buzzer sounds, operation continues	Check wiring and sensor
Mn3	Maintenance alarm for output 3	Buzzer sounds, operation continues	Check wiring and sensor
"rtc"	The real time clock has lost its setting	Energy saving function disabled	Reprogram clock
CONTROL MESSAGE	CAUSE	RESULTS OF CONTROL CONDITION	NOTES
 On	A call-for-heat condition	The burner operating sequence should begin.	If the burner does not operate, check safety devices or Remote Proving Interlock
 Flashing	The remote enable/disable has been triggered	The small flame icon will flash indicating the standby state	The R1-R2 terminals have been opened by the remote master control. The heater will remain in standby.
	Integral circulation pump	The integral circulation pump will operate until the water temperature has equalized	Pump may operate before, during or after the call-for-heat

## 9.14 Audible Alarm

The TempTrac audible alarm is activated each time a connected alarm condition occurs. The following are representative alarm conditions that may be connected to and activate the TempTrac audible alarm (some alarms may be connected to and operate separately from the TempTrac on some products).

- High/low water temperature alarm
- Probe failures
- External thermostat limit failure
- Flame Failure
- High and low gas pressure
- Low water

The audible alarm is silenced by pressing any button (alarm condition still present).

# MAXIM WATER HEATER

## 9.15 Alarm Recovery

- Probe failure alarm automatically ends after normal operation is re-established. Check connections before replacing the probe.
- Temperature alarms “HA” and “LA” automatically stop as soon as probe 1 senses temperatures within normal operating parameters.
- Digital input 2 & 3 alarms recover when condition(s) listed above are normalized and any button is pressed (if used). Resetting the alarm condition may require resetting individual safety devices or cycling main power switch.
- RTC alarm stops after programming the real time clock.
- RTF alarm requires the replacement of the real time clock.

**For additional information, contact the PVI Industries Customer Service Dept at 800-784-8326.**

## 10 INITIAL STARTUP REQUIREMENTS

Installation must be complete prior to performing initial startup; and the startup must be complete prior to placing the water heater into service. Starting the water heater without proper piping, combustion air, venting or electrical connections or control settings can be dangerous and may void the product warranty. The following startup instructions must be followed precisely in order to achieve proper and efficient operation to assure trouble-free service life.

**WARNING: Proper startup must be made by a qualified installer or service agency, who must read and follow the supplied instructions and appliance markings. Failure to complete proper startup before use, tampering with controls or not following all instructions and markings may damage this equipment, void the warranty and may result in property damage, personal injury or death.**

A Start-up Form is included with each product and must be completed by the qualified installer or service agency conducting the startup and must be returned to the manufacture to register the warranty. Copies are available at [www.pvi.com](http://www.pvi.com).

### 10.1 Tools and Instrumentation Required

- Stack temperature gauge
- Manometer for checking gas pressure (2 minimum)
- Stack Draft Gauge
- Electronic Combustion Analyzer
- AC/DC multimeter with a 20,000 ohm/volt DC rating
- Ammeter
- Oil pressure gauge (100-350 psi) (oil only)
- Vacuum gauge (0-30" Hg.) (oil only)
- Smoke spot tester (oil only)
- Normal Hand Tools

### 10.2 Resources

- Product Installation & Maintenance Manuals
- Start-Up Reports with Instructions
- SU-3 Gas Burner Manual PV500-56 (< 400,000 Btu/h)
- BG400 Gas Burner Manual PV500-21A (140,000 thru 1,400,000 Btu/h)
- B40 Oil Burner PV500-22A (1.0 thru 10.0 gph)
- B Series Oil Burner PV500-22 (> 10 gph oil)
- Combination Gas/Oil Burner (Consult factory)

# MAXIM WATER HEATER

## 10.3 On Site Considerations

- Electrical Supply in accordance with Nameplate Rating
- Uncontaminated Combustion Air
- Adequate Fuel Supply
- Treated Water Supply (Water heaters)
- Consistent Draft

## 11 START-UP PROCEDURES AND OPERATION

**CAUTION:** Do not relight pilot or start burner with combustion chamber full of gas or oil vapor, or with very hot combustion chamber.

1. The burner manufacturer's installation and service manual start-up procedures for the individual burner on your water heater may be part of this manual or will be shipped with the burner. Study the information carefully and follow the burner manufacturer's recommendations.
2. Because of the many different burners and control systems, the instructions in this section are general information and refer to the water heater with either power gas, oil or combination gas/oil burner installed.
3. Fill the water heater tank with water. Open the relief valve or a nearby hot water faucet to allow air in the tank to escape. Be sure all connections into the tank are tight as leaks at tank fittings will damage the insulation.
4. The top thermostat is a temperature limiting safety device set at 200°F. The thermostats are set at the factory at 130°F on the upper operating thermostat and 120°F on the lower operating thermostat. The lower operating thermostat should be set 10° lower than the upper operating thermostat setting. Adjustment may be made by turning the thermostat dial to the desired temperature.

# MAXIM WATER HEATER

## 12 PERIODIC MAINTENANCE

**WARNING: Start-up should only be performed by a qualified technician.**

**CAUTION:** Do not relight pilot or start burner with combustion chamber full of gas vapor, or with very hot combustion chamber.

1. Study the Installation & Maintenance manual for the burner carefully.
2. Fill the water heater tank with water. Open the relief valve to allow air in the tank to escape. Be sure all connections into the tank are tight, as leaks at tank fittings will damage the insulation.

### 12.1 Gas Burners

1. Conduct the following gas train leakage test before start-up, annual intervals and prior to investigating the cause of any reported occurrences of delayed ignition.
  - a. Using an appropriate bubble detection solution, thoroughly coat all gas train pipe connections. If any bubbles are detected, the leaking connection must be tightened, recoated and rechecked to assure stoppage of the leak.
  - b. Attach a manometer, to measure gas pressure, at the manual gas shutoff valve located just upstream of the gas train. Adjust gas train inlet pressure to the specified value (e.g. 14 in. W.C.), and tightly close the gas train manual shutoff valve closest to burner.
  - c. Reattach the manometer to the gas train manual shutoff valve at the burner and record the measured gas pressure in inches of water column (in W.C.). Measure gas pressure again after 15 minutes. If gas pressure has increased 0.5" W.C. or more, the gas leak must be isolated to one or more of the operating gas valves; for example, a solenoid actuated gas shutoff valve. After any leaking valve is replaced, the reassembled gas train must be leak tested again before start-up is attempted.
2. While nozzle is removed, look inside through burner for obstructions.
3. Check fan rotation.
4. Check air shutter setting (guideline on burner tag).
5. Drill hole in vent pipe 12" to 24" from heater flue outlet but below draft regulator (for analysis equipment).
6. Attach voltmeter to controller to record flame signal.
7. Check inlet static gas pressure before gas train (see rating on heater decal).
8. Attach manometer to manifold to read pressure (tapping closest to burner).
9. Turn off main manual gas valve and start burner on pilot (if burner has separate pilot).
10. Set pilot to give good flame signal with just enough gas to reliably light pilot.

**NOTE:** If there is no pilot, set gas pressure (guideline on burner tag).
11. Slowly open main gas and set gas pressure (guideline on burner tag).
12. Check flame signal (should be in range called for by control).
13. Check inlet flow gas pressure before gas train.

**NOTE:** Should meet or exceed minimum rating listed on heater decal.
14. Perform flue gas analysis after achieving water temperatures above 120°F:
  - Vent draft in stack (should be negative .02" to negative .06" W.C.)
  - Net stack temperature should be 300°F - 400°F (read in stack, all units)
  - O<sub>2</sub> should be from 4% to 7%
  - CO<sub>2</sub> should be from 8% to 10%
  - CO should not exceed 200 PPM

# MAXIM WATER HEATER

## 12.2 Oil Burners

1. Pull nozzle assembly from burner and check gap settings on electrodes (see I&M).
2. While nozzle is removed, look inside through burner for obstructions.
3. Check fan rotation and purge air from oil pump by bumping motor contactor.
4. Check air shutter setting (guideline on burner tag).
5. Drill hole in vent pipe 12" to 24" from heater flue outlet but below draft regulator (for analysis equipment).
6. Attach voltmeter to controller to record flame signal.
7. Connect a 300-psi gauge to pressure side of oil pump. Connect vacuum gauge to supply side of oil pump (15" hg maximum allowed).
8. Set oil pressure to pressure on data decal (refer to I&M manual for two stage burner).
9. Check flame signal **(should be in range called for by control 14-18 VDC or 4-6 VDC if UV)**.
  - Perform flue gas analysis after achieving water temperatures above 120°F
  - Vent draft in stack (should be negative .02" to negative .06" W.C.)
  - Net stack temperature should be 300°F - 400°F on high fire
  - O<sub>2</sub> should be from 4% to 7%. NOTE: Both low and high fire reading
  - CO<sub>2</sub> should be from 10.5% to 12.7%. NOTE: Both low and high fire reading
  - CO should not exceed 200 PPM
  - Smoke should be less than #2



# MAXIM WATER HEATER

## 13 PERIODIC MAINTENANCE

1. A preventative maintenance program should be established to assure a long, trouble-free life of the water heater.
2. To control sediment and scale buildup in the water heater, the tank should be flushed at two- or three-month intervals depending on water conditions in your location. To flush, turn off electrical disconnect switch to prevent the burner from operating. Open the drain valve and allow water to flow through the tank until it runs clear. Close the drain valve and turn the electrical switch on. Between tank flushes, draining two or three gallons from the tank on a weekly basis will also help prevent the accumulation of sediment.
3. A scale of lime will normally form and accumulate in the heater during operation. The lime is formed from the natural chemicals in the water that precipitate out during the heating cycles. Some water supplies contain more of these chemicals than others, and the scale buildup will occur more rapidly. Other factors affecting the scale buildup are the amount of hot water used and the temperature of the water. The more hot water used, the more fresh water containing the scale-forming chemicals are brought into the tank. As the temperature of the water increases, the rate of scale deposited will be increased.

Sediment and scale accumulations on heating surfaces will reduce the water heater's ability to transfer heat to the stored water. When the heating energy from the burner cannot be effectively transferred to the water in the tank, the metal will overheat. Overheating will cause the metal in the heating surfaces to overheat and lose structural strength. Over time, this will result in leakage.

4. The tank has an opening suitable for inspection and cleaning use. The tank should be inspected for scale buildup through this opening. If scale is present, it can be loosened with a high-pressure stream of water. The smaller pieces can be flushed through the drain and the larger pieces removed by hand. The frequency of inspections will be determined by the rate of scale buildup. We recommend 30-60 day intervals.
5. Periodic inspections and check-out of the burner ignition system, control system and fuel valve operation (for tight close-off) should be made. Refer to the burner installation instructions for recommendations.  
When oil burners are used, the flue tubes and flue baffles should be inspected periodically and cleaned if necessary. A maladjusted oil burner producing excessive smoke will result in soot collecting in the flue tubes. Once sooting starts, it accelerates rapidly and will eventually block air movement through the flue tubes.
6. Examine the venting system at least once each year for proper connections and alignment. Oil the blower motor and wipe oil and dust from the burner at regular intervals. The blower inlet will collect dust from the air during operation. Clean the blower wheel when necessary. The burner should be cleaned each year according to burner manufacturer's recommended procedures. Inspect all parts and make replacements when necessary. Check wiring for loose connections and burned wires.
7. The temperature and pressure relief valve should be checked at regular intervals to determine its condition for safe operation. The openings inside the valve may become inoperative. If the valve does not open and close properly when tested, it must be replaced. Replace relief valve with a like kind or one meeting the requirements stated on the rating decal located adjacent to the relief valve mounting location.

**CAUTION:** The relief valve is a primary safety device.

8. Extended shutdown of the appliance and restarting are as follows:
  - a. Turn off all power on fuel supplies.
  - b. Drain and flush tank as previously discussed.
  - c. Tag power switch(es) that fuel is off and tank is empty.
  - d. Refill tank with water and energize fuel and power switch(es) to restart. Reset all controls and conduct start-up of the appliance as discussed in this manual.

# MAXIM WATER HEATER

## 14 RECOMMENDED MAINTENANCE SCHEDULE

### 1. Annual Maintenance

- a. Check all joints and pipe connections for tightness, corrosion or deterioration.
- b. Check the electronic-ignition system for quick ignition and a proper flame signal.
- c. Check all safety controls including thermostats for proper operation.
- d. Check safety shut-off valves for operation and tightness.
- e. Test flame failure detection system.
- f. Test high limit and operating temperature controls.
- g. Conduct a combustion test.
- h. Perform leakage test on pilot and main gas valves.
- i. Test air switch in functionality.

### 2. Semi-Annually

- a. Recalibrate all indicating and recording gauges.
- b. Check flame failure detection system components.
- c. Check piping and wiring of all interlocks and shutoff valves.
- d. Inspect burner components.
- e. Check igniter.
- f. Test high and low gas pressure interlocks.

### 3. Monthly Maintenance

- a. Test low-water cutoff device and alarm (if equipped).
- b. Check flue, vent, stack, or outlet dampers.
- c. Check flame signal strength.
- d. Check flame failure detection system.
- e. Listen to and visually check the pilot and main fuel valves.

### 4. Daily Maintenance

- a. Check gauges, monitors, and indicators.
- b. Check instrument and equipment settings.

### 5. As Required

- a. Check drip leg and gas strainers.
- b. Test flame failure detection system.
- c. Test temperature and pressure relief valves
- d. Tank flush and cleanout.

# MAXIM WATER HEATER

## 15 REQUIREMENTS FOR THE COMMONWEALTH OF MASSACHUSETTS:

This equipment complies with Massachusetts State Fuel Gas and Plumbing Codes CMR 248 3.00-10.00 as amended.

- a) For all side wall horizontally vented gas fueled equipment installed in every dwelling, building or structure used in whole or in part for residential purposes, including those owned or operated by the Commonwealth and where the side wall exhaust vent termination is less than seven (7) feet above finished grade in the area of the venting, including but not limited to decks and porches, the following requirements shall be satisfied:
  1. **INSTALLATION OF CARBON MONOXIDE DETECTORS:** At the time of installation of the side wall horizontal vented gas fueled equipment, the installing plumber or gasfitter shall observe that a hard wired carbon monoxide detector with an alarm and battery back-up is installed on the floor level where the gas equipment is to be installed. In addition, the installing plumber or gasfitter shall observe that a battery operated or hard wired carbon monoxide detector with an alarm is installed on each additional level of the dwelling, building or structure served by the side wall horizontal vented gas fueled equipment. It shall be the responsibility of the property owner to secure the services of qualified licensed professionals for the installation of hard wired carbon monoxide detectors.
    - a. In the event that the side wall horizontally vented gas fueled equipment is installed in a crawl space or an attic, the hard wired carbon monoxide detector with alarm and battery back-up may be installed on the next adjacent floor level.
    - b. In the event that the requirements of this subdivision cannot be met at the time of completion of installation, the owner shall have a period of thirty (30) days to comply with the above requirements; provided, however, that during said thirty (30) day period, a battery operated carbon monoxide detector with an alarm shall be installed.
  2. **APPROVED CARBON MONOXIDE DETECTORS:** Each carbon monoxide detector as required in accordance with the above provisions shall comply with NFPA 720 and be ANSI/UL 2034 listed and IAS certified.
  3. **SIGNAGE:** A metal or plastic identification plate shall be permanently mounted to the exterior of the building at a minimum height of eight (8) feet above grade directly in line with the exhaust vent terminal for the horizontally vented gas fueled heating appliance or equipment. The sign shall read, in print size no less than one-half (1/2) inch in size, "GAS VENT DIRECTLY BELOW. KEEP CLEAR OF ALL OBSTRUCTIONS".
  4. **INSPECTION:** The state or local gas inspector of the side wall horizontally vented gas fueled equipment shall not approve the installation unless, upon inspection, the inspector observes carbon monoxide detectors and signage installed in accordance with the provisions of 248 CMR 5.08(2)(a)1 through 4.
- b) **EXEMPTIONS:** The following equipment is exempt from 248 CMR 5.08(2)(a)1 through 4:
  1. The equipment listed in Chapter 10 entitled "Equipment Not Required To Be Vented" in the most current edition of NFPA 54 as adopted by the Board; and
  2. Product approved side wall horizontally vented gas fueled equipment installed in a room or structure separate from the dwelling, building or structure used in whole or in part for residential purposes.
- c) **MANUFACTURERS REQUIREMENTS – GAS EQUIPMENT VENTING SYSTEM REQUIRED:** When the manufacturer of Product Approved side wall horizontally mounted gas equipment provides a venting system design or venting system components with the equipment, the instructions provided by the manufacturer for the installation of the equipment and the venting shall include:
  1. Detailed instructions for the installation of the venting system or the venting system components: and
  2. A complete parts list for the venting system design or venting system.
- d) **MANUFACTURER REQUIREMENTS – GAS EQUIPMENT VENTING SYSTEM NOT PROVIDED:** When the manufacturer of product approved side wall horizontally vented gas fueled equipment does not provide the parts for the venting of flue gases, but identifies "special venting systems," the following requirements shall be satisfied by the manufacturer:
  1. The referenced "special venting system" instructions shall be included with the appliance or equipment installation instructions; and
  2. The "special venting systems" shall be product approved by the Board, and the instructions for that system shall include a parts list and detailed installation instructions. Detailed installation instructions and parts list are available online for the following venting systems for use on this equipment:

Heat Fab Website – Saf-T-Vent EZ-Seal Installation & Maintenance Instructions  
<http://www.heatfab.com/products/saf-t-vent/saf-t-vent-ez-seal.aspx?id=x1>

Metal-Fab Website – Metal-Fab CORR/GUARD Installation & Maintenance Instructions  
[http://www.metal-fabcommercial.com/content/products/corr\\_guard](http://www.metal-fabcommercial.com/content/products/corr_guard)Selkirk Metalbestos Website – Saf-T-Vent EZ-Seal (same as Heat Fab) Installation & Maintenance Instructions  
<http://www.selkirkusa.com/products/venting.aspx>
- e) Relief valve must be installed and plumbed in accordance with the authority having jurisdiction. Massachusetts 248 CMR requires relief valve discharge 12 inches off finished floor
- f) A copy of all installation instructions for all side wall horizontally vented gas fueled equipment, all venting instructions, all parts lists for venting instructions, and/or all venting design instructions shall remain with the appliance or equipment at the completion of the installation.

# MAXIM WATER HEATER

---

Since PVI cannot control the use of the appliance, water conditions, or maintenance, the warranty on the heat exchanger does not cover poor performance, structural failure, or leaking due to an excessive accumulation of scale.

---

Warranty Forms Ship Separately with Each Product

MODEL NUMBER: \_\_\_\_\_

SERIAL NUMBER: \_\_\_\_\_

INSTALLATION DATE: \_\_\_\_\_