

# COBREX®

## Double Wall Instantaneous Steam-to-Water Heater

### Dimensions for Single Heat Exchanger Models with sub-cooler

#### Configurations 1, 2, 3 and 5

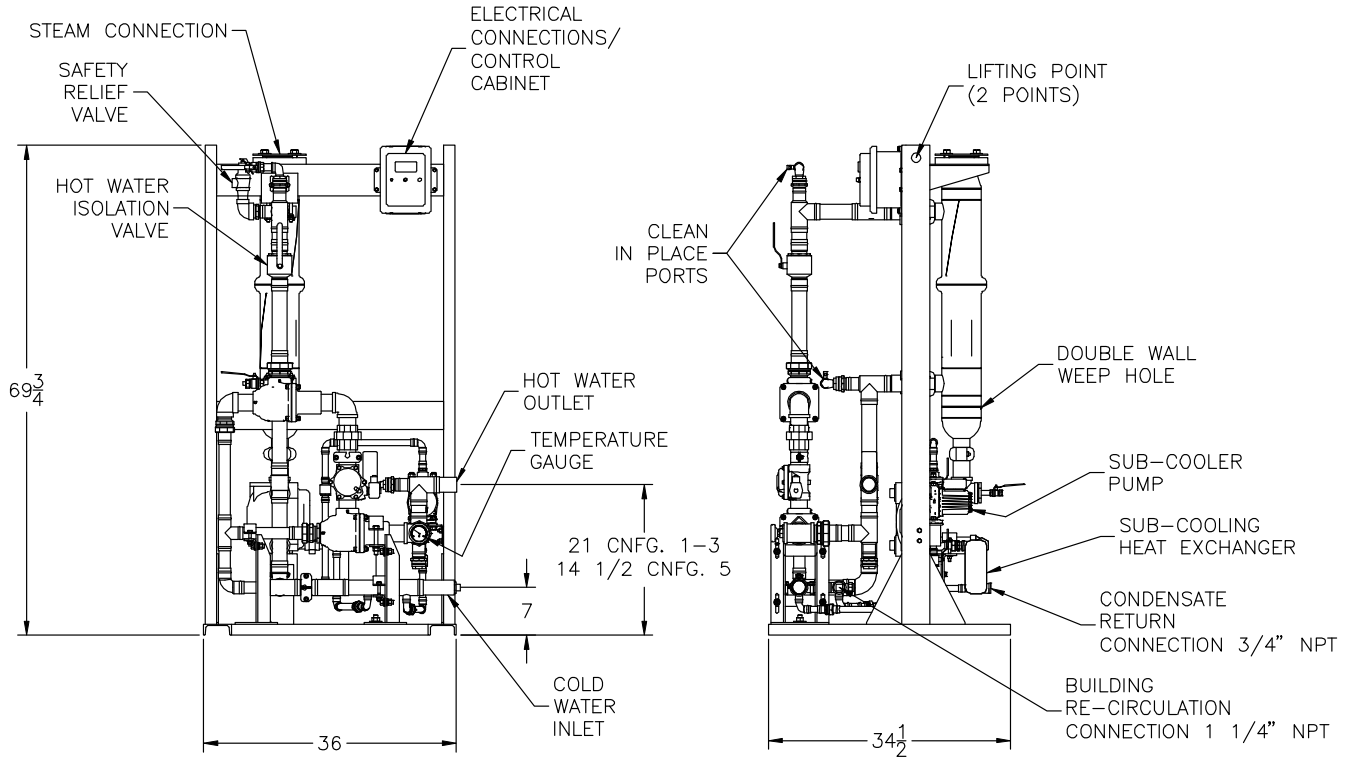

4 gpm minimum recirculation flow through CCX required; can be provided by optional intra-skid circulator.  
Optional intra-skid circulator not shown.  
All dimensions are in inches.

Plumbing connections				
Product Configuration*	Cold Inlet	Hot Outlet	Steam Connection	Weight (lbs)
1, 2	1-1/2"	1-1/2"	3"	600
3	2"	2"	3"	625
5	3"	3" NPT	3"	650

Consult factory for dimensional changes due to option additions.

Electrical requirements: 120V, 60 Hz., 9 amps service to a single-point connection.

\* For product configuration, refer to performance documents PV8427, PV8428 and PV8429.

For standard and optional equipment list, refer to form PV8426.

PVI reserves the right to change the design and specification without notice.



PVI Industries, LLC  
Fort Worth, TX • (800) 784-8326 • www.pvi.com

